

# AC axial fan

sickle-shaped blades (S series)

with guard grille for full nozzle

S6D800-BJ01-17 ebmpapst Datasheet

sales@fansco.com

www.fansco.com

Limited partnership · Headquarters Mulfingen

Amtsgericht (court of registration) Stuttgart · HRA 590344

General partner Elektrobau Mulfingen GmbH · Headquarters Mulfingen

Amtsgericht (court of registration) Stuttgart · HRB 590142

## Nominal data

<b>Type</b>	<b>S6D800-BJ01-17</b>		
<b>Motor</b>	<b>M6D138-LA</b>		
Phase		3~	3~
Nominal voltage	VAC	400	400
Wiring		Δ	Y
Frequency	Hz	50	50
Method of obtaining data		ml	ml
Valid for approval/standard		CE	CE
Speed (rpm)	min <sup>-1</sup>	895	685
Power consumption	W	2000	1270
Current draw	A	4.3	2.5
Max. back pressure	Pa	180	100
Max. back pressure	in. wg	0.72	0.4
Min. ambient temperature	°C	-40	-40
Max. ambient temperature	°C	60	60
Starting current	A	13	4.3

ml = Max. load · me = Max. efficiency · fa = Free air · cs = Customer specification · ce = Customer equipment  
Subject to change

## Data according to Commission Regulation (EU) 327/2011 (EN 17166)

		Actual	Req. 2015			
01 Overall efficiency $\eta_{es}$	%	35.9	35.2	09 Power consumption $P_e$	kW	1.75
02 Measurement category		A		09 Air flow $q_v$	m <sup>3</sup> /h	16835
03 Efficiency category		Static		09 Pressure increase $p_{fs}$	Pa	135
04 Efficiency grade N		40.7	40	10 Speed (rpm) n	min <sup>-1</sup>	905
05 Variable speed drive		No		11 Specific ratio*		1.00

Data obtained at optimum efficiency level.  
The ErP data is determined using a motor-impeller combination in a standardized measurement setup.

\* Specific ratio =  $1 + p_{fs} / 100\,000\text{ Pa}$

LU-199664



# AC axial fan

sickle-shaped blades (S series)

with guard grille for full nozzle

## Technical description

<b>Weight</b>	33.7 kg
<b>Size</b>	800 mm
<b>Motor size</b>	138
<b>Rotor surface</b>	Cast in aluminum
<b>Terminal box material</b>	PP plastic
<b>Blade material</b>	Die-cast aluminum
<b>Guard grille material</b>	Steel, coated with black plastic (RAL 9005)
<b>Number of blades</b>	5
<b>Blade pitch</b>	-5°
<b>Airflow direction</b>	V
<b>Direction of rotation</b>	Clockwise, viewed toward rotor
<b>Degree of protection</b>	IP54
<b>Insulation class</b>	"F"
<b>Moisture (F) / Environmental (H) protection class</b>	H2
<b>Ambient temperature note</b>	Occasional start-up at temperatures between -40°C and -25°C is permitted. For continuous operation at ambient temperatures below -25°C (such as refrigeration applications), use must be made of a fan design with special low-temperature bearings.
<b>Max. permitted ambient temp. for motor (transport/storage)</b>	+80 °C
<b>Min. permitted ambient temp. for motor (transport/storage)</b>	-40 °C
<b>Installation position</b>	Any
<b>Condensation drainage holes</b>	On rotor and stator sides
<b>Mode</b>	S1
<b>Motor bearing</b>	Ball bearing
<b>Touch current according to IEC 60990 (measuring circuit Fig. 4, TN system)</b>	<= 3.5 mA
<b>Electrical hookup</b>	Terminal box
<b>Motor protection</b>	Thermal overload protector (TOP) with basic insulation
<b>Protection class</b>	I (with customer connection of protective earth)
<b>Conformity with standards</b>	EN 60034-1 (2010); CE
<b>Approval</b>	EAC; VDE



# AC axial fan

sickle-shaped blades (S series)  
with guard grille for full nozzle

## Product drawing

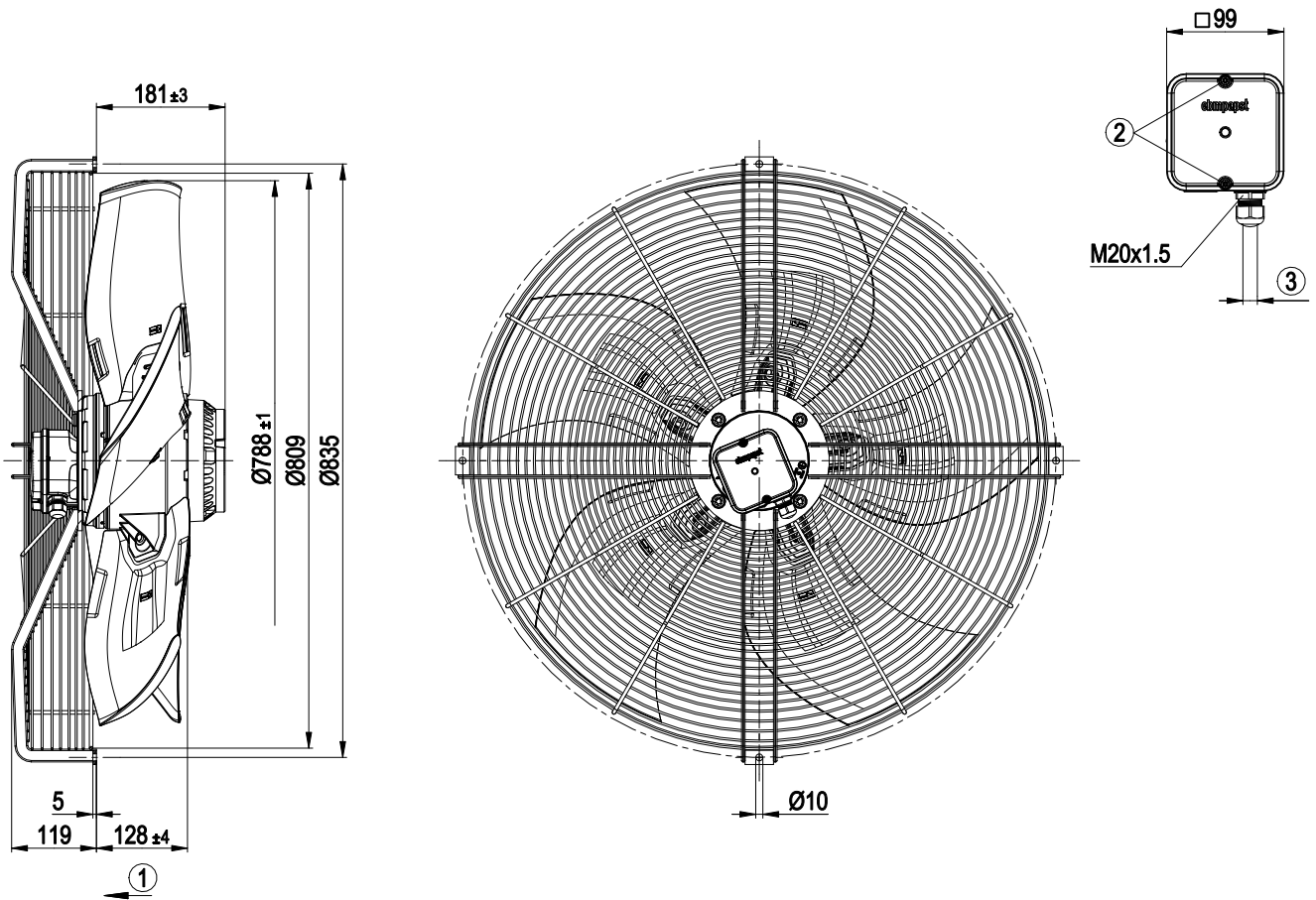

1	Airflow direction "V"
2	Tightening torque $1.5 \pm 0.2$ Nm
3	Cable diameter min. 7 mm, max. 14 mm, tightening torque $2 \pm 0.3$ Nm



# AC axial fan

sickle-shaped blades (S series)  
with guard grille for full nozzle

## Connection diagram



Δ	Delta connection	Y	Star connection	L1	= U1 = black
L2	= V1 = blue	L3	= W1 = brown	W2	yellow
U2	green	V2	white	TOP	2x gray
PE	green/yellow				



# AC axial fan

sickle-shaped blades (S series)  
with guard grille for full nozzle

## Curves: Air performance 50 Hz

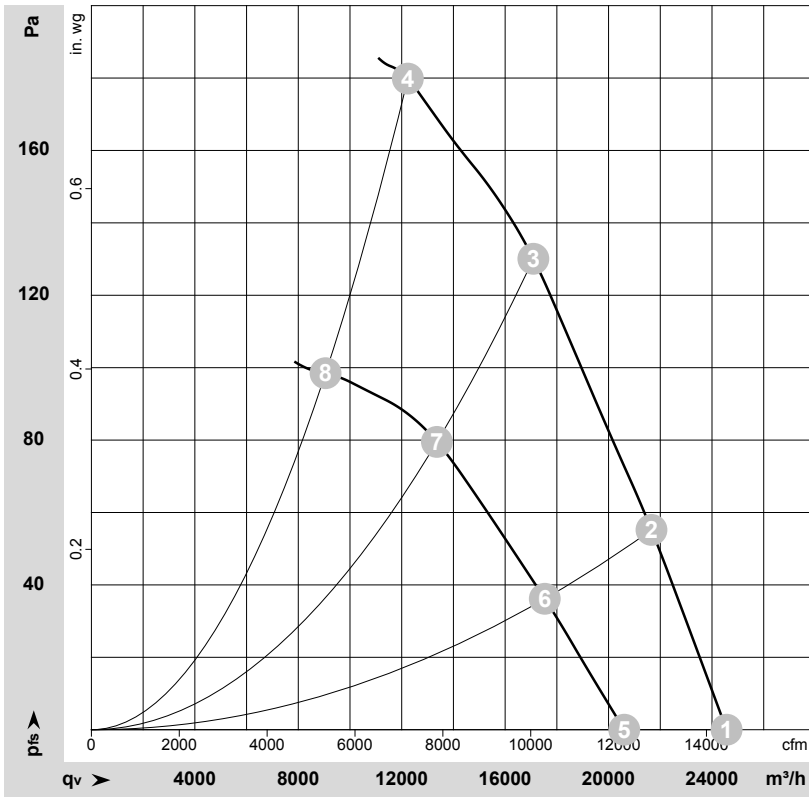

$\rho = 1.15 \text{ kg/m}^3 \pm 2 \%$

Measurement: LU-100640-1  
Measurement: LU-100800-1

Air performance measured according to ISO 5801 installation category A. For detailed information on the measurement setup, contact ebm-papst. Intake sound level: Sound power level according to ISO 13347 / sound pressure level measured at 1 m distance from fan axis. The values given are valid under the specified measuring conditions and may vary due to conditions of installation. For deviations from the standard configuration, the parameters have to be checked on the installed unit.

## Measured values

	Wired	U	f	n	P <sub>e</sub>	I	LpA <sub>in</sub>	LwA <sub>in</sub>	q <sub>v</sub>	P <sub>fs</sub>	q <sub>v</sub>	P <sub>fs</sub>
		V	Hz	min <sup>-1</sup>	W	A	dB(A)	dB(A)	m <sup>3</sup> /h	Pa	cfm	in. wg
1	Δ	400	50	930	1374	3.22	67	73	24565	0	14460	0.00
2	Δ	400	50	915	1567	3.41	65	71	21660	55	12750	0.22
3	Δ	400	50	900	1762	3.64	67	73	17090	130	10060	0.52
4	Δ	400	50	895	2000	4.30	72	79	12240	180	7205	0.72
5	Y	400	50	785	1007	1.89	63	70	20605	0	12130	0.00
6	Y	400	50	745	1082	2.03	61	68	17535	36	10320	0.14
7	Y	400	50	705	1162	2.18	61	68	13360	80	7865	0.32
8	Y	400	50	685	1270	2.50	65	73	9055	100	5330	0.40

Wired = Wiring · U = Voltage · f = Frequency · n = Speed (rpm) · P<sub>e</sub> = Power consumption · I = Current draw · LpA<sub>in</sub> = Sound pressure level intake side · LwA<sub>in</sub> = Sound power level intake side  
q<sub>v</sub> = Air flow · P<sub>fs</sub> = Pressure increase

