

S6D800-AH13-11

Emerson

# AC axial fan

with guard grille for short nozzle

S6D800-AH13-11 ebmpapst Datasheet

sales@fansco.com

www.fansco.com

Limited partnership · Headquarters Muldingen

Amtsgericht (court of registration) Stuttgart · HRA 590344

General partner Elektrobau Muldingen GmbH · Headquarters Muldingen

Amtsgericht (court of registration) Stuttgart · HRB 590142



## Nominal data

Type	S6D800-AH13-11		
Motor	M6D138-HF		
Phase		3~	3~
Nominal voltage	VAC	400	400
Wiring		Δ	Y
Frequency	Hz	50	50
Method of obtaining data		ml	ml
Valid for approval/standard		CE	CE
Speed	min <sup>-1</sup>	880	665
Power consumption	W	1400	890
Current draw	A	2.9	1.67
Max. back pressure	Pa	140	80
Min. ambient temperature	°C	-40	-40
Max. ambient temperature	°C	60	60
Starting current	A	9.2	3.1

ml = Max. load · me = Max. efficiency · fa = Free air · cs = Customer specification · ce = Customer equipment  
Subject to change

## Data according to ErP Directive

		Actual	Req. 2015			
01 Overall efficiency $\eta_{es}$	%	36.3	34.4	09 Power consumption $P_e$	kW	1.31
02 Measurement category		A		09 Air flow $q_v$	m <sup>3</sup> /h	14025
03 Efficiency category		Static		09 Pressure increase $p_{fs}$	Pa	123
04 Efficiency grade N		41.9	40	10 Speed n	min <sup>-1</sup>	890
05 Variable speed drive		No		11 Specific ratio*		1.00

Data obtained at optimum efficiency level.  
The ErP data is determined using a motor-impeller combination in a standardized measurement setup.

\* Specific ratio =  $1 + p_g / 100\,000\text{ Pa}$

LU-136943



S6D800-AH13-11

Emerson

# AC axial fan

with guard grille for short nozzle

## Technical description

Weight	30.4 kg
Fan size	800 mm
Rotor surface	Cast in aluminum
Terminal box material	PP plastic
Blade material	Sheet aluminum insert, sprayed with PP plastic
Guard grille material	Steel, coated with black plastic (RAL 9005)
Number of blades	5
Blade pitch	-5°
Airflow direction	"V"
Direction of rotation	Clockwise, viewed toward rotor
Degree of protection	IP54
Insulation class	"F"
Moisture (F) / Environmental (H) protection class	F3-1
Max. permitted ambient temp. for motor (transport/storage)	+ 80 °C
Min. permitted ambient temp. for motor (transport/storage)	- 40 °C
Installation position	Any
Condensation drainage holes	On rotor and stator sides
Mode	S1
Motor bearing	Ball bearing
Touch current according to IEC 60990 (measuring circuit Fig. 4, TN system)	<= 3.5 mA
Electrical hookup	Via terminal box
Motor protection	Thermal overload protector (TOP) with basic insulation
Protection class	I (with customer connection of protective earth)
Conformity with standards	EN 60034-1 (2010); EN 61800-5-1; CE
Approval	CSA C22.2 No. 100; EAC; UL 1004-1



S6D800-AH13-11

Emerson

# AC axial fan

with guard grille for short nozzle

## Product drawing

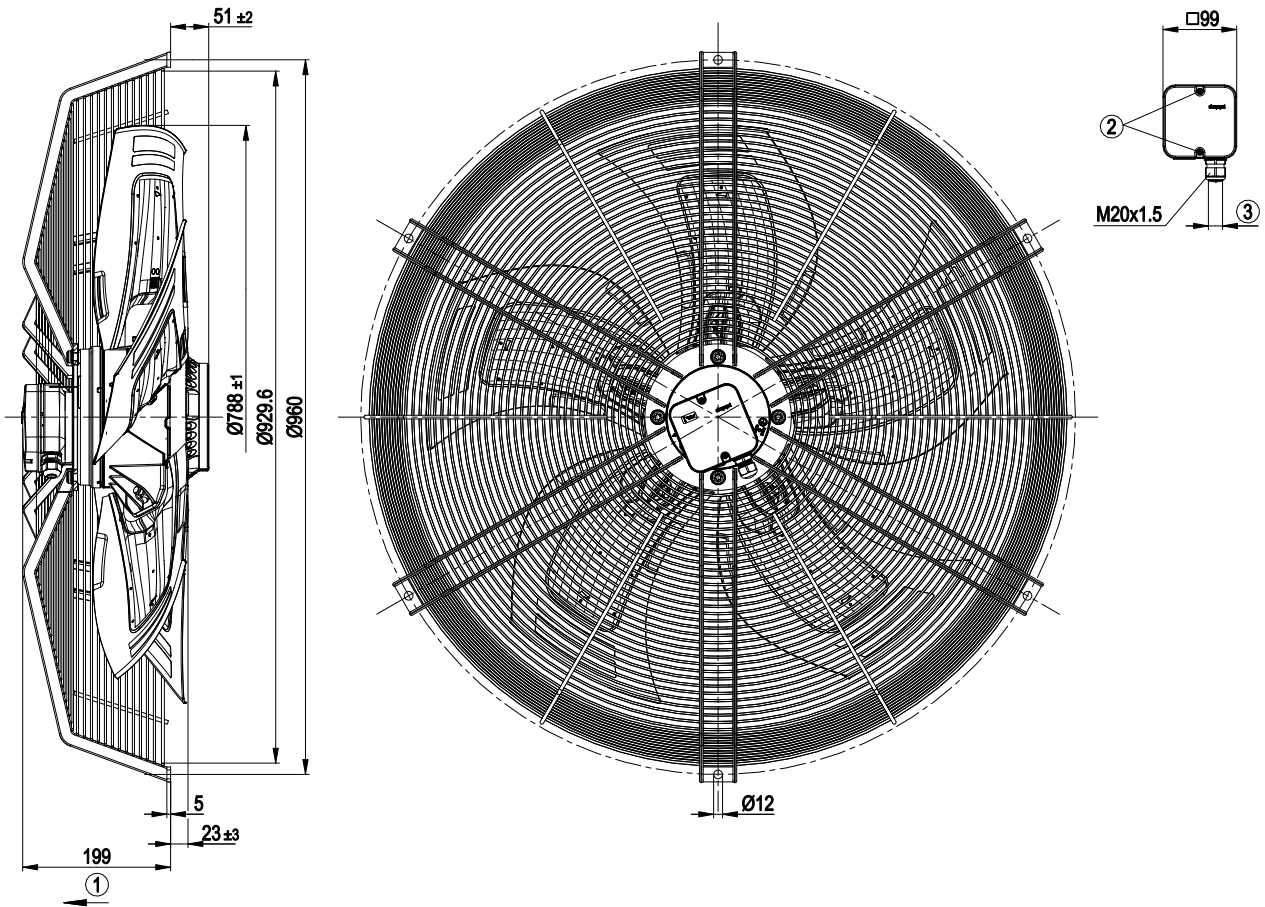

1	Direction of air flow "V"
2	Tightening torque $1.5 \pm 0.2$ Nm
3	Cable diameter: min. 7 mm, max. 14 mm, tightening torque $2 \pm 0.3$ Nm



## Connection diagram

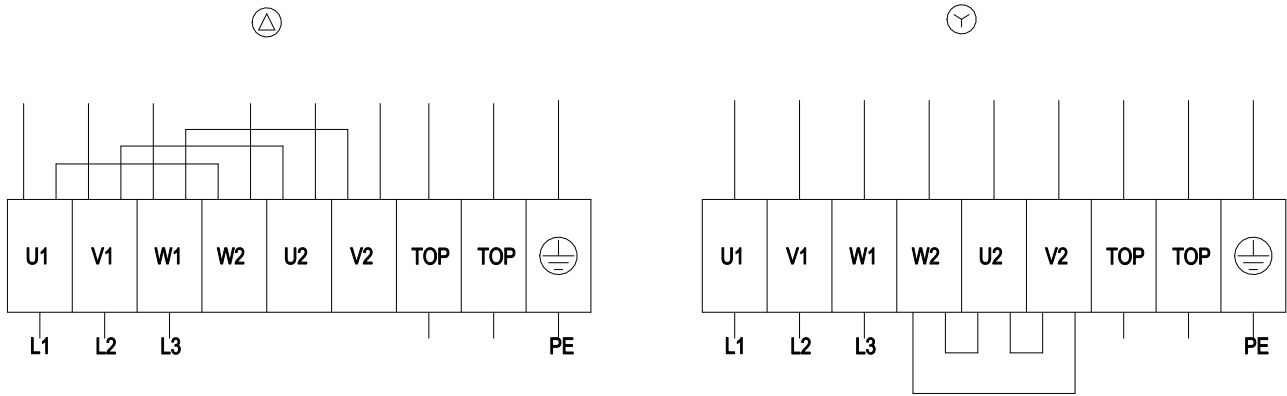

Δ	Delta connection	Y	Star connection	L1	= U1 = black
L2	= V1 = blue	L3	= W1 = brown	W2	yellow
U2	green	V2	white	TOP	2x gray
PE	green/yellow				

## Curves: Air performance 50 Hz

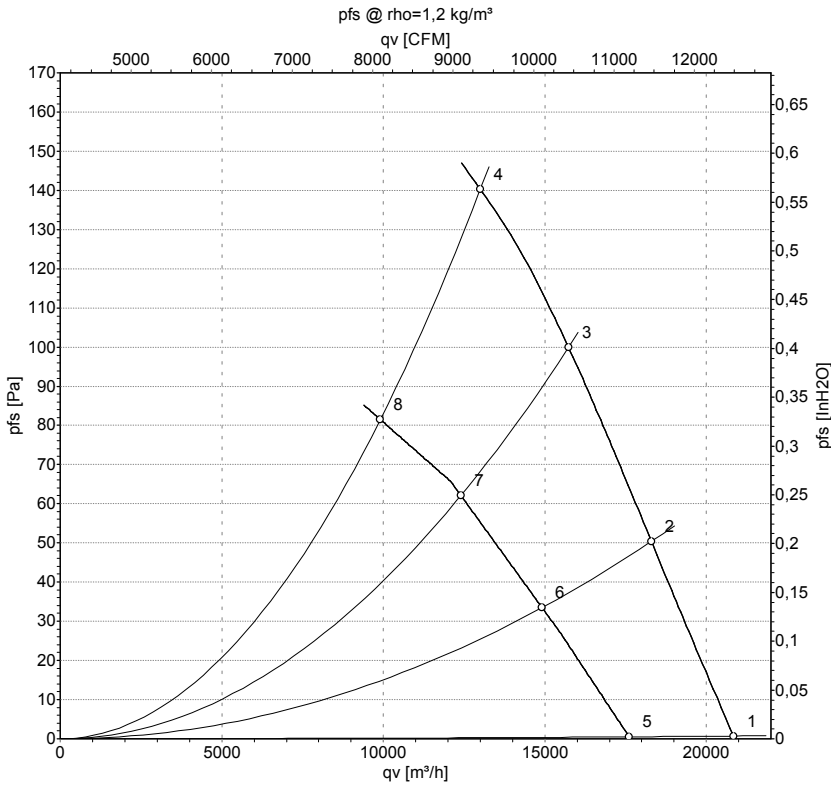

Measurement: LU-136943-1  
Measurement: LU-136973-1

Air performance measured according to ISO 5801 installation category A. For detailed information on the measurement setup, contact ebm-papst. Intake sound level: Sound power level according to ISO 13347 / sound pressure level measured at 1 m distance from fan axis. The values given are valid under the specified measuring conditions and may vary due to conditions of installation. For deviations from the standard configuration, the parameters have to be checked on the installed unit.

## Measured values

	Wired	U	f	n	P <sub>e</sub>	I	LpA <sub>in</sub>	LwA <sub>in</sub>	LwA <sub>out</sub>	qv	p <sub>fs</sub>
		V	Hz	min <sup>-1</sup>	W	A	dB(A)	dB(A)	dB(A)	m <sup>3</sup> /h	Pa
1	Δ	400	50	930	947	2.36	68	75	75	20845	0
2	Δ	400	50	915	1119	2.53	64	71	70	18300	50
3	Δ	400	50	900	1254	2.69	65	71	70	15735	100
4	Δ	400	50	880	1400	2.90	67	74	73	13000	140
5	Y	400	50	785	695	1.29	64	71	71	17610	0
6	Y	400	50	740	776	1.45	60	66	66	14915	33
7	Y	400	50	705	831	1.55	59	66	64	12405	62
8	Y	400	50	665	890	1.67	60	67	66	9910	80

Wired = Wiring · U = Power supply · f = Frequency · n = Speed · P<sub>e</sub> = Power consumption · I = Current draw · LpA<sub>in</sub> = Sound pressure level intake side · LwA<sub>in</sub> = Sound power level intake side  
LwA<sub>out</sub> = Sound power level outlet side · qv = Air flow · p<sub>fs</sub> = Pressure increase

