

# AC axial fan - HyBlade

sickle-shaped blades (S series)

with guard grille for short nozzle

S6D710-AQ01-02 ebmpapst Datasheet

sales@fansco.com

www.fansco.com

Limited partnership · Headquarters Muldingen

Amtsgericht (court of registration) Stuttgart · HRA 590344

General partner Elektrobau Muldingen GmbH · Headquarters Muldingen

Amtsgericht (court of registration) Stuttgart · HRB 590142



## Nominal data

Type	S6D710-AQ01-02		
Motor	M6D110-IA		
Phase		3~	3~
Nominal voltage	VAC	400	400
Wiring		Δ	Y
Frequency	Hz	50	50
Method of obtaining data		ml	ml
Valid for approval/standard		CE	CE
Speed (rpm)	min <sup>-1</sup>	880	670
Power consumption	W	840	530
Current draw	A	1.74	0.94
Max. back pressure	Pa	115	68
Max. back pressure	inH <sub>2</sub> O	0.46	0.27
Min. ambient temperature	°C	-40	-40
Max. ambient temperature	°C	50	50
Starting current	A	5	

ml = Max. load · me = Max. efficiency · fa = Free air · cs = Customer specification · ce = Customer equipment  
Subject to change

## Data according to ErP Directive

		Actual	Req. 2015			
01 Overall efficiency $\eta_{ES}$	%	33	33	09 Power consumption $P_e$	kW	0.79
02 Measurement category		A		09 Air flow $q_v$	m <sup>3</sup> /h	9505
03 Efficiency category		Static		09 Pressure increase $p_{fs}$	Pa	99
04 Efficiency grade N		40	40	10 Speed (rpm) n	min <sup>-1</sup>	885
05 Variable speed drive		No		11 Specific ratio*		1.00

Data obtained at optimum efficiency level.  
The ErP data is determined using a motor-impeller combination in a standardized measurement setup.

\* Specific ratio =  $1 + p_{fs} / 100\,000\text{ Pa}$

LU-108461



# AC axial fan - HyBlade

sickle-shaped blades (S series)

with guard grille for short nozzle

## Technical description

Weight	18.3 kg
Fan size	710 mm
Rotor surface	Cast in aluminum
Terminal box material	PP plastic
Blade material	Sheet aluminum insert, sprayed with PP plastic
Guard grille material	Steel, coated with black plastic (RAL 9005)
Number of blades	5
Blade pitch	-5°
Airflow direction	"A"
Direction of rotation	Clockwise, viewed toward rotor
Degree of protection	IP54
Insulation class	"F"
Moisture (F) / Environmental (H) protection class	F3-1
Max. permitted ambient temp. for motor (transport/storage)	+80 °C
Min. permitted ambient temp. for motor (transport/storage)	-40 °C
Installation position	Shaft horizontal or rotor on bottom; rotor on top on request
Condensation drainage holes	On rotor side
Mode	S1
Motor bearing	Ball bearing
Touch current according to IEC 60990 (measuring circuit Fig. 4, TN system)	<= 3.5 mA
Electrical hookup	Via terminal box
Motor protection	Thermal overload protector (TOP) with basic insulation
With cable	Axial
Protection class	I (with customer connection of protective earth)
Conformity with standards	EN 61800-5-1; CE
Approval	EAC; VDE



# AC axial fan - HyBlade

sickle-shaped blades (S series)  
with guard grille for short nozzle

## Product drawing

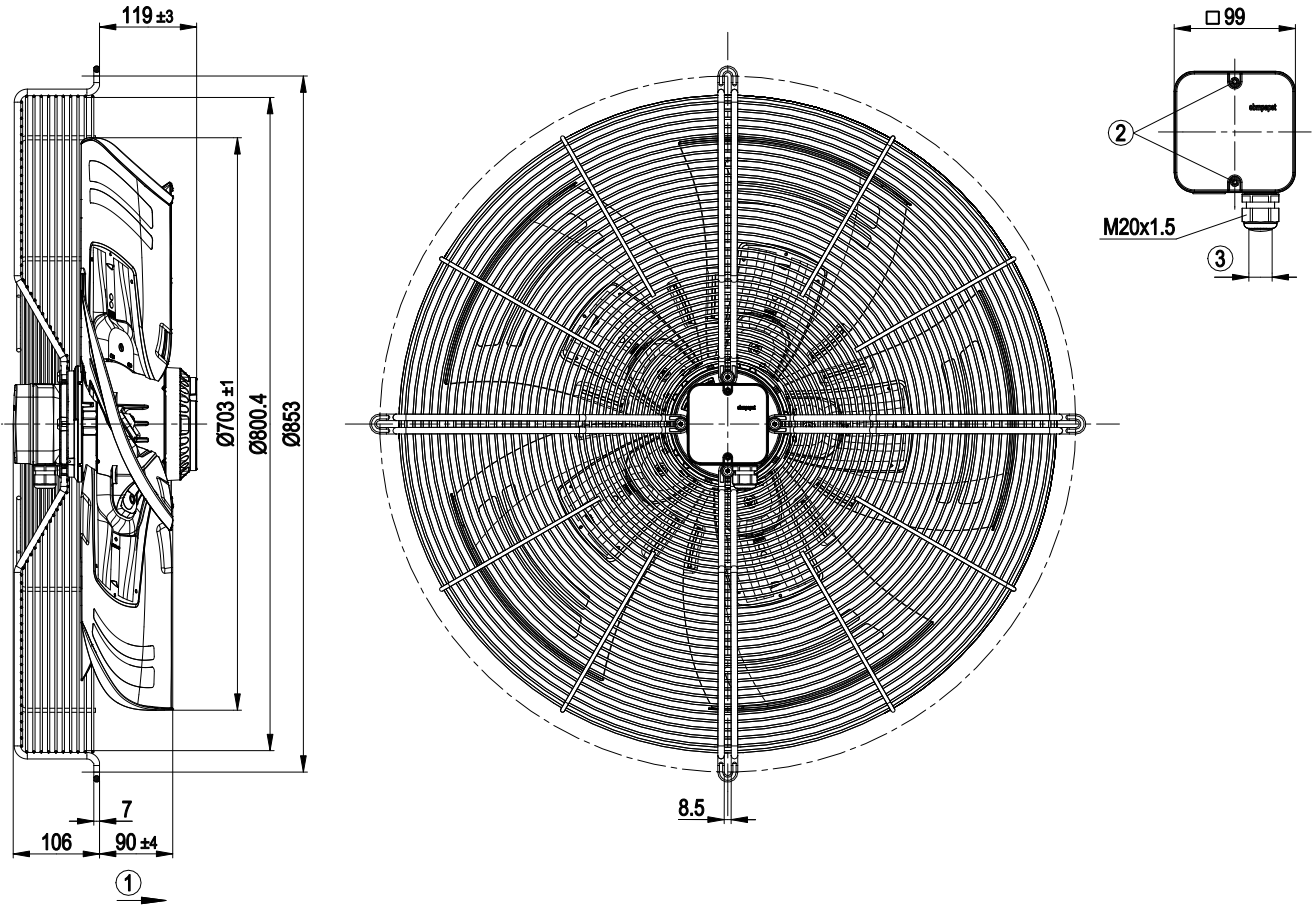

1	Direction of air flow "A"
2	Tightening torque 1.5 ± 0.2 Nm
3	Cable diameter min. 6 mm, max. 12 mm, tightening torque 2 ± 0.3 Nm



# AC axial fan - HyBlade

sickle-shaped blades (S series)  
with guard grille for short nozzle

## Connection diagram



Δ	Delta connection	Y	Star connection	L1	= U1 = black
L2	= V1 = blue	L3	= W1 = brown	W2	yellow
U2	green	V2	white	TOP	2x gray
PE	green/yellow				



# AC axial fan - HyBlade

sickle-shaped blades (S series)  
with guard grille for short nozzle

## Curves: Air performance 50 Hz

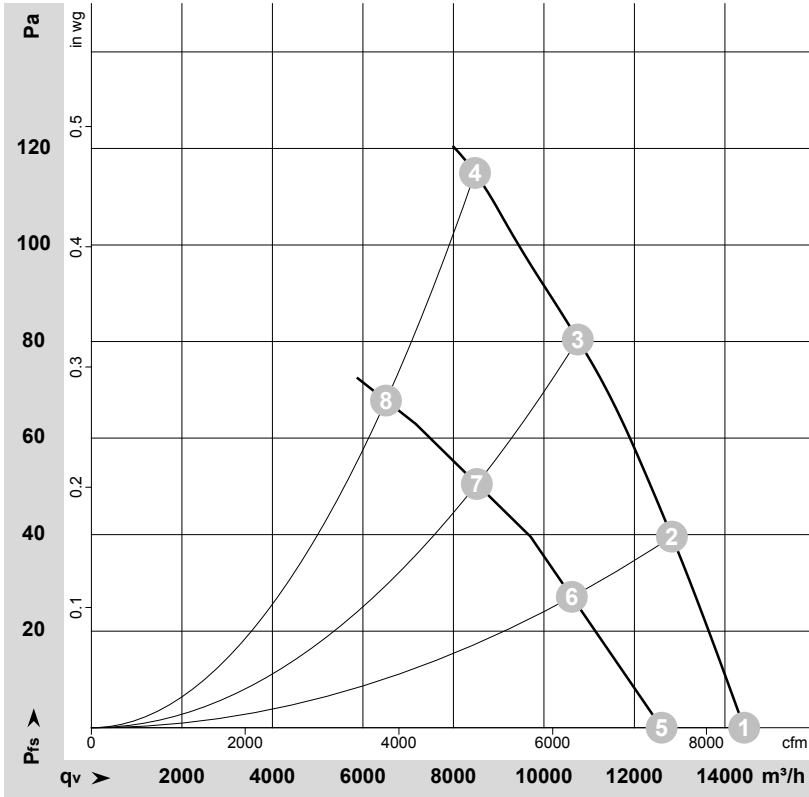

$\rho = 1.15 \text{ kg/m}^3 \pm 2 \%$

Measurement: LU-108461-1  
Measurement: LU-113657-1

Air performance measured according to ISO 5801 installation category A. For detailed information on the measurement setup, contact ebm-papst. Intake sound level: Sound power level according to ISO 13347 / sound pressure level measured at 1 m distance from fan axis. The values given are valid under the specified measuring conditions and may vary due to conditions of installation. For deviations from the standard configuration, the parameters have to be checked on the installed unit.

## Measured values

	Wired	U	f	n	P <sub>e</sub>	I	LpA <sub>in</sub>	LwA <sub>in</sub>	LwA <sub>out</sub>	qv	p <sub>fs</sub>	qv	p <sub>fs</sub>
		V	Hz	min <sup>-1</sup>	W	A	dB(A)	dB(A)	dB(A)	m <sup>3</sup> /h	Pa	CFM	inH <sub>2</sub> O
1	Δ	400	50	935	521	1.45	66	73	72	14425	0	8490	0.00
2	Δ	400	50	915	630	1.52	63	69	69	12830	40	7550	0.16
3	Δ	400	50	895	747	1.64	61	68	67	10750	80	6325	0.32
4	Δ	400	50	880	840	1.74	65	71	71	8475	115	4990	0.46
5	Y	400	50	810	377	0.69	63	69	69	12600	0	7415	0.00
6	Y	400	50	755	436	0.78	59	65	64	10615	27	6250	0.11
7	Y	400	50	705	487	0.86	57	63	62	8520	50	5015	0.20
8	Y	400	50	670	530	0.94	59	65	65	6510	68	3830	0.27

Wired = Wiring · U = Power supply · f = Frequency · n = Speed (rpm) · P<sub>e</sub> = Power consumption · I = Current draw · LpA<sub>in</sub> = Sound pressure level intake side · LwA<sub>in</sub> = Sound power level intake side  
LwA<sub>out</sub> = Sound power level outlet side · qv = Air flow · p<sub>fs</sub> = Pressure increase

