

# AC axial fan - HyBlade

sickle-shaped blades (S series)

with square short nozzle

S6D630-AO05-04 ebmpapst Datasheet

sales@fansco.com

www.fansco.com

Limited partnership · Headquarters Muldingen

Amtsgericht (court of registration) Stuttgart · HRA 590344

General partner Elektrobau Muldingen GmbH · Headquarters Muldingen

Amtsgericht (court of registration) Stuttgart · HRB 590142

## Nominal data

Type	S6D630-AO05-04						
Motor	M6D110-GF						
Phase		3~	3~	3~	3~	3~	3~
Nominal voltage	VAC	230	230	277	400	400	480
Wiring		$\Delta$	$\Delta$	$\Delta$	Y	Y	Y
Frequency	Hz	50	60	60	50	60	60
Method of obtaining data		ml	ml	ml	ml	ml	ml
Valid for approval/standard		CE	CE	CE	CE	CE	CE
Speed (rpm)	min <sup>-1</sup>	925	1040	1090	925	1040	1090
Power consumption	W	510	730	800	510	730	800
Current draw	A	2.16	2.39	2.45	1.25	1.38	1.42
Max. back pressure	Pa	100	128	140	100	128	140
Max. back pressure	in. wg	0.4	0.51	0.56	0.4	0.51	0.56
Min. ambient temperature	°C	-40	-40	-40	-40	-40	-40
Max. ambient temperature	°C	65	55	55	65	55	55
Starting current	A	7.2	6.45		4.3	3.9	

ml = Max. load · me = Max. efficiency · fa = Free air · cs = Customer specification · ce = Customer equipment  
Subject to change

## Data according to Commission Regulation (EU) 327/2011

	Actual	Req. 2015				
01 Overall efficiency $\eta_{es}$	%	34.7	31.8	09 Power consumption $P_e$	kW	0.51
02 Measurement category		A		09 Air flow $q_v$	m <sup>3</sup> /h	6000
03 Efficiency category		Static		09 Pressure increase $p_{fs}$	Pa	109
04 Efficiency grade N		42.9	40	10 Speed (rpm) n	min <sup>-1</sup>	925
05 Variable speed drive		No		11 Specific ratio*		1.00

Data obtained at optimum efficiency level.  
The ErP data is determined using a motor-impeller combination in a standardized measurement setup.

\* Specific ratio =  $1 + p_{fs} / 100\,000\text{ Pa}$

LU-108273



# AC axial fan - HyBlade

sickle-shaped blades (S series)

with square short nozzle

## Technical description

Weight	12.5 kg
Fan size	630 mm
Rotor surface	Cast in aluminum
Terminal box material	PP plastic
Blade material	Press-fitted sheet steel blank, sprayed with PP plastic
Guard grille material	Steel, phosphated and coated with black plastic (RAL 9005)
Number of blades	5
Blade pitch	-10°
Airflow direction	"A"
Direction of rotation	Clockwise, viewed toward rotor
Degree of protection	IP54
Insulation class	"F"
Moisture (F) / Environmental (H) protection class	H2
Max. permitted ambient temp. for motor (transport/storage)	+80 °C
Min. permitted ambient temp. for motor (transport/storage)	-40 °C
Installation position	Shaft horizontal or rotor on bottom; rotor on top on request
Condensation drainage holes	On rotor side
Mode	S1
Motor bearing	Ball bearing
Touch current according to IEC 60990 (measuring circuit Fig. 4, TN system)	<= 3.5 mA
Electrical hookup	Via terminal box
Motor protection	Thermal overload protector (TOP) with basic insulation
With cable	Axial
Protection class	I (with customer connection of protective earth)
Conformity with standards	EN 61800-5-1; CE
Approval	VDE; EAC; CSA C22.2 No. 100; UL 1004-1



# AC axial fan - HyBlade

sickle-shaped blades (S series)

with square short nozzle

## Product drawing

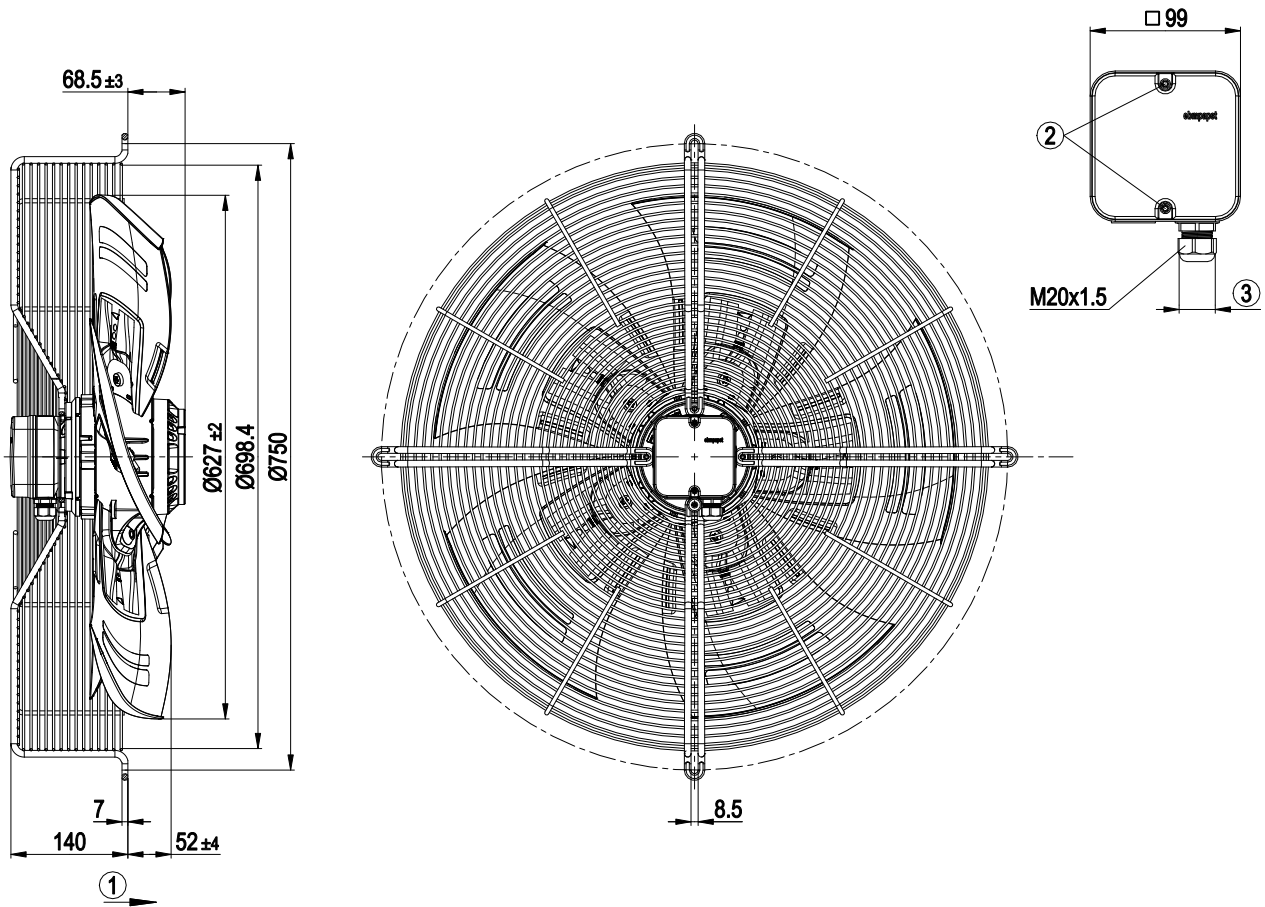

1	Direction of air flow "A"
2	Tightening torque 1.5 ± 0.2 Nm
3	Cable diameter min. 6 mm, max. 10 mm, tightening torque 2.5 ± 0.4 Nm



# AC axial fan - HyBlade

sickle-shaped blades (S series)

with square short nozzle

## Connection diagram



Δ	Delta connection	Y	Star connection	L1	= U1 = black
L2	= V1 = blue	L3	= W1 = brown	W2	yellow
U2	green	V2	white	TOP	2x gray
PE	green/yellow				



# AC axial fan - HyBlade

sickle-shaped blades (S series)

with square short nozzle

## Curves: Air performance 50 Hz

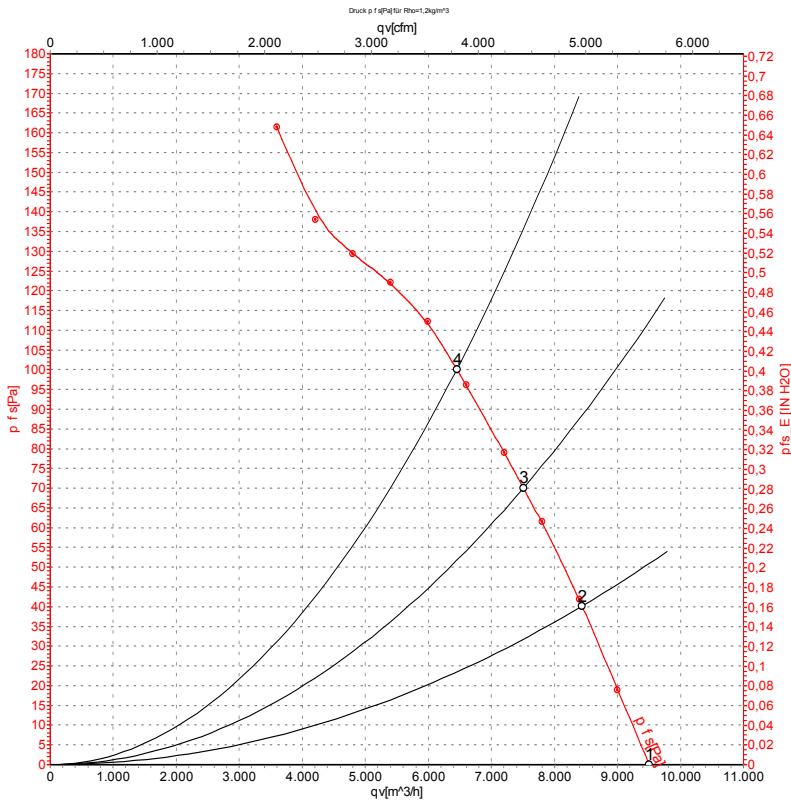

Measurement: LU-108273-1

Air performance measured according to ISO 5801 installation category A. For detailed information on the measurement setup, contact ebm-papst. Intake sound level: Sound power level according to ISO 13347 / sound pressure level measured at 1 m distance from fan axis. The values given are valid under the specified measuring conditions and may vary due to conditions of installation. For deviations from the standard configuration, the parameters have to be checked on the installed unit.

## Measured values

	Wired	U	f	n	P <sub>e</sub>	I	LpA <sub>in</sub>	LwA <sub>in</sub>	LwA <sub>out</sub>	q <sub>v</sub>	p <sub>fs</sub>	q <sub>v</sub>	p <sub>fs</sub>
		V	Hz	min <sup>-1</sup>	W	A	dB(A)	dB(A)	dB(A)	m <sup>3</sup> /h	Pa	cfm	in. wg
1	Y	400	50	955	351	1.16	64	70	69	9505	0	5595	0.00
2	Y	400	50	945	413	1.18	61	67	67	8440	40	4965	0.16
3	Y	400	50	935	460	1.22	60	66	65	7510	70	4420	0.28
4	Y	400	50	925	510	1.25	62	68	67	6450	100	3800	0.40

Wired = Wiring · U = Power supply · f = Frequency · n = Speed (rpm) · P<sub>e</sub> = Power consumption · I = Current draw · LpA<sub>in</sub> = Sound pressure level intake side · LwA<sub>in</sub> = Sound power level intake side  
 LwA<sub>out</sub> = Sound power level outlet side · q<sub>v</sub> = Air flow · p<sub>fs</sub> = Pressure increase



# AC axial fan - HyBlade

sickle-shaped blades (S series)

with square short nozzle

## Curves: Air performance 60 Hz

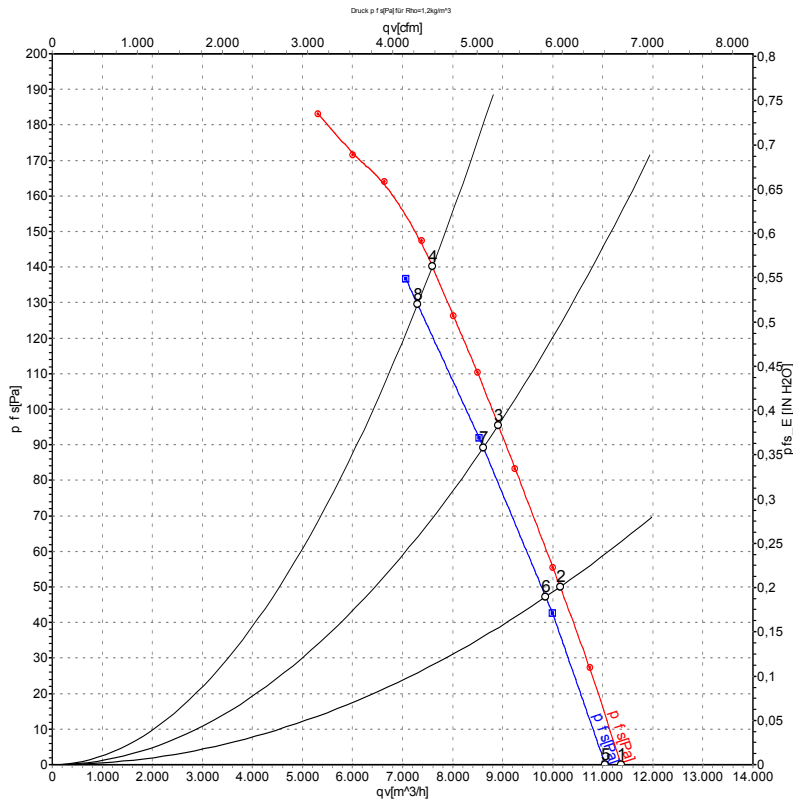

Measurement: LU-108281-1  
Measurement: LU-108317-1

Air performance measured according to ISO 5801 installation category A. For detailed information on the measurement setup, contact ebm-papst. Intake sound level: Sound power level according to ISO 13347 / sound pressure level measured at 1 m distance from fan axis. The values given are valid under the specified measuring conditions and may vary due to conditions of installation. For deviations from the standard configuration, the parameters have to be checked on the installed unit.

## Measured values

	Wired	U	f	n	P <sub>e</sub>	I	LpA <sub>in</sub>	LwA <sub>in</sub>	LwA <sub>out</sub>	q <sub>v</sub>	p <sub>fs</sub>	q <sub>v</sub>	p <sub>fs</sub>
		V	Hz	min <sup>-1</sup>	W	A	dB(A)	dB(A)	dB(A)	m <sup>3</sup> /h	Pa	cfm	in. wg
1	Y	480	60	1135	536	1.22	68	74	74	11360	0	6685	0.00
2	Y	480	60	1120	628	1.29	65	71	71	10150	50	5975	0.20
3	Y	480	60	1105	722	1.36	63	70	69	8910	95	5245	0.38
4	Y	480	60	1090	800	1.42	66	72	72	7595	140	4470	0.56
5	Y	400	60	1105	487	1.04	67	73	73	11050	0	6505	0.00
6	Y	400	60	1085	574	1.16	64	71	70	9860	47	5805	0.19
7	Y	400	60	1065	655	1.27	62	69	69	8615	89	5070	0.36
8	Y	400	60	1040	730	1.38	65	71	71	7300	130	4295	0.52

Wired = Wiring · U = Power supply · f = Frequency · n = Speed (rpm) · P<sub>e</sub> = Power consumption · I = Current draw · LpA<sub>in</sub> = Sound pressure level intake side · LwA<sub>in</sub> = Sound power level intake side  
LwA<sub>out</sub> = Sound power level outlet side · q<sub>v</sub> = Air flow · p<sub>fs</sub> = Pressure increase

