

# AC axial fan

sickle-shaped blades (S series), single-intake  
with guard grille for short nozzle

S6D560-AJ03-02 ebmpapst Datasheet  
sales@fansco.com  
www.fansco.com

Limited partnership · Headquarters Mulfingen  
Amtsgericht (court of registration) Stuttgart · HRA 590344  
General partner Elektrobau Mulfingen GmbH · Headquarters Mulfingen  
Amtsgericht (court of registration) Stuttgart · HRB 590142

## Nominal data

Type	S6D560-AJ03-02		
Motor	M6D110-EF		
Phase		3~	3~
Nominal voltage	VAC	400	400
Wiring		Δ	Y
Frequency	Hz	50	50
Method of obtaining data		ml	ml
Valid for approval/standard		-	-
Speed (rpm)	min <sup>-1</sup>	870	660
Power consumption	W	450	280
Current draw	A	0.88	0.48
Max. back pressure	Pa	75	43
Max. back pressure	inH <sub>2</sub> O	0.3	0.17
Min. ambient temperature	°C	-40	-40
Max. ambient temperature	°C	70	70
Starting current	A	2.5	0.85

ml = Max. load · me = Max. efficiency · fa = Free air · cs = Customer specification · ce = Customer equipment  
Subject to change



# AC axial fan

sickle-shaped blades (S series), single-intake  
with guard grille for short nozzle

## Technical description

Weight	13.3 kg
Fan size	560 mm
Rotor surface	Cast in aluminum
Terminal box material	PP plastic
Blade material	Sheet aluminum insert, sprayed with PP plastic
Guard grille material	Steel, coated with black plastic (RAL 9005)
Number of blades	5
Blade pitch	0°
Airflow direction	"A"
Direction of rotation	Clockwise, viewed toward rotor
Degree of protection	IP54
Insulation class	"F"
Moisture (F) / Environmental (H) protection class	F3-1
Max. permitted ambient temp. for motor (transport/storage)	+ 80 °C
Min. permitted ambient temp. for motor (transport/storage)	- 40 °C
Installation position	Shaft horizontal or rotor on bottom; rotor on top on request
Condensation drainage holes	On rotor side
Mode	S1
Motor bearing	Ball bearing
Touch current according to IEC 60990 (measuring circuit Fig. 4, TN system)	<= 3.5 mA
Electrical hookup	Via terminal box
Motor protection	Thermal overload protector (TOP) with basic insulation
With cable	Axial
Protection class	I (with customer connection of protective earth)
Conformity with standards	EN 61800-5-1
Approval	EAC; VDE



# AC axial fan

sickle-shaped blades (S series), single-intake  
with guard grille for short nozzle

## Product drawing

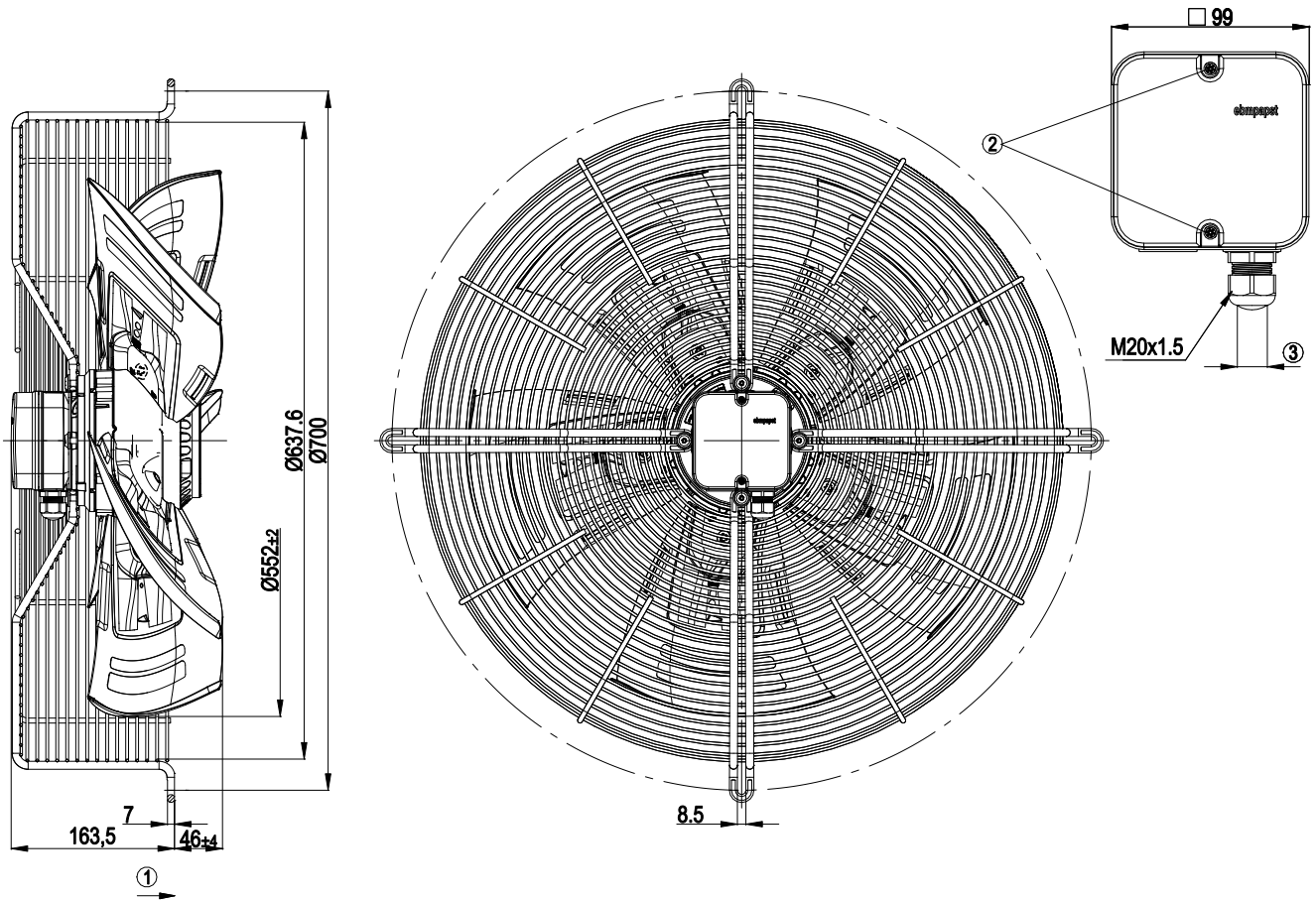

1	Direction of air flow "A"
2	Tightening torque $1.5 \pm 0.2$ Nm
3	Cable diameter min. 6 mm, max. 12 mm, tightening torque $2.0 \pm 0.3$ Nm



# AC axial fan

sickle-shaped blades (S series), single-intake  
with guard grille for short nozzle

## Connection diagram

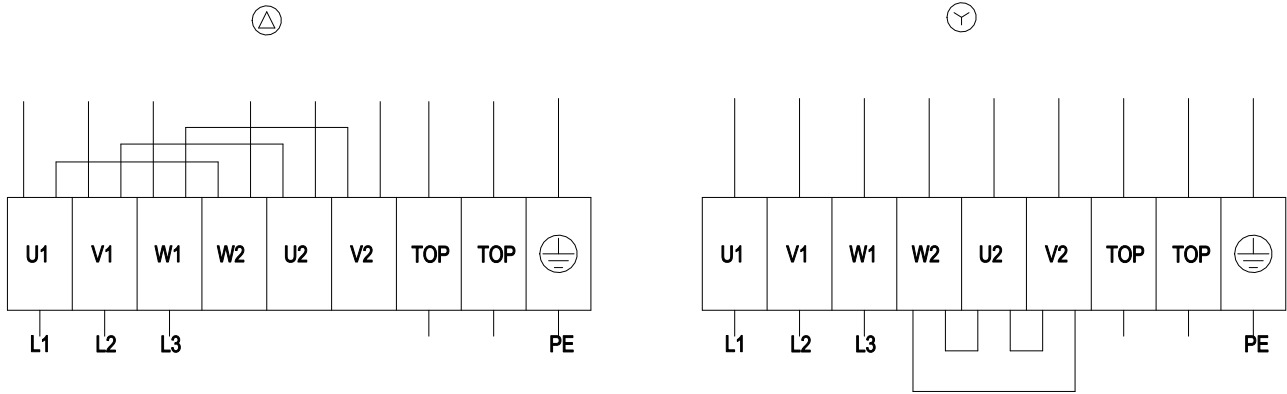

Δ	Delta connection	Y	Star connection	L1	= U1 = black
L2	= V1 = blue	L3	= W1 = brown	W2	yellow
U2	green	V2	white	TOP	2x gray
PE	green/yellow				



# AC axial fan

sickle-shaped blades (S series), single-intake  
with guard grille for short nozzle

## Curves: Air performance 50 Hz

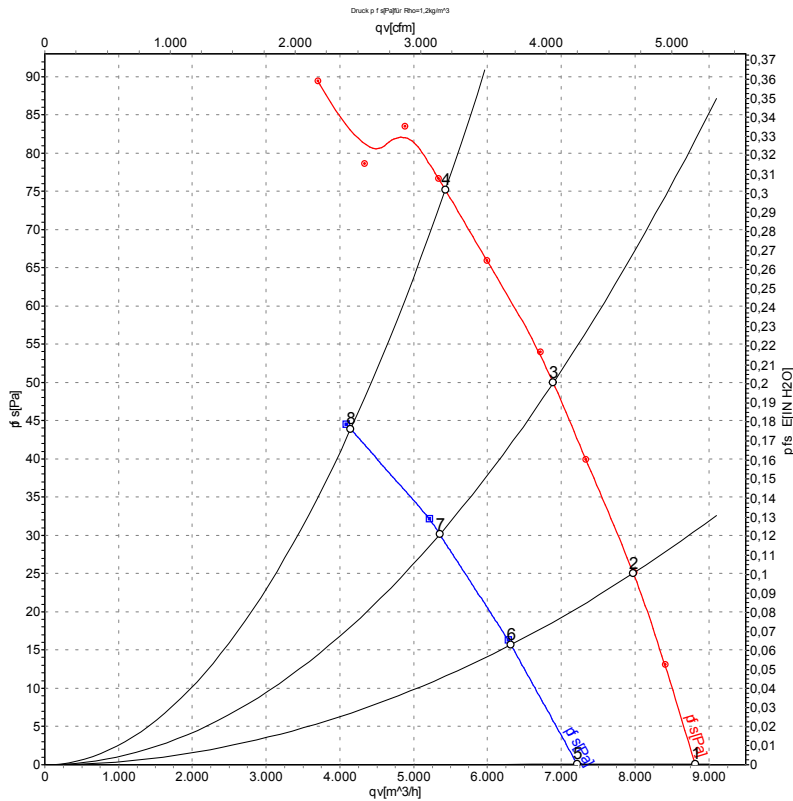

Measurement: LU-11122-1  
Measurement: LU-113342-1

Air performance measured according to ISO 5801 installation category A. For detailed information on the measurement setup, contact ebm-papst. Intake sound level: Sound power level according to ISO 13347 / sound pressure level measured at 1 m distance from fan axis. The values given are valid under the specified measuring conditions and may vary due to conditions of installation. For deviations from the standard configuration, the parameters have to be checked on the installed unit.

## Measured values

	Wired	U	f	n	P <sub>e</sub>	I	LpA <sub>in</sub>	LwA <sub>in</sub>	LwA <sub>out</sub>	q <sub>v</sub>	p <sub>fs</sub>	q <sub>v</sub>	p <sub>fs</sub>
		V	Hz	min <sup>-1</sup>	W	A	dB(A)	dB(A)	dB(A)	m <sup>3</sup> /h	Pa	CFM	inH <sub>2</sub> O
1	Δ	400	50	905	361	0.78	59	65	66	8815	0	5190	0.00
2	Δ	400	50	895	391	0.81	58	65	65	7975	25	4695	0.10
3	Δ	400	50	880	420	0.83	58	65	65	6890	50	4055	0.20
4	Δ	400	50	870	450	0.88	63	69	69	5430	75	3195	0.30
5	Y	400	50	730	251	0.42	54	60	60	7220	0	4250	0.00
6	Y	400	50	700	262	0.44	52	58	59	6315	16	3720	0.06
7	Y	400	50	680	274	0.46	54	59	59	5355	30	3150	0.12
8	Y	400	50	660	280	0.48	55	61	61	4150	43	2440	0.17

Wired = Wiring · U = Power supply · f = Frequency · n = Speed (rpm) · P<sub>e</sub> = Power consumption · I = Current draw · LpA<sub>in</sub> = Sound pressure level intake side · LwA<sub>in</sub> = Sound power level intake side  
LwA<sub>out</sub> = Sound power level outlet side · q<sub>v</sub> = Air flow · p<sub>fs</sub> = Pressure increase

