

ebm-papst ventilator (Shanghai)Co.,Ltd.

No.418, Hua jing Road, Wai Gao qiao Free Trade Zone, Pudong

S6D500-AD01-09 ebmpapst Datasheet

sales@fansco.com

www.fansco.com

## Nominal data

Type	S6D500-AD01-09				
Motor	M6D110-GF				
Phase		3~	3~	3~	3~
Nominal voltage	VAC	400	400	400	400
Wiring		Δ	Y	Δ	Y
Frequency	Hz	50	50	60	60
Method of obtaining data		ml	ml	ml	ml
Valid for approval/standard		-	-	-	-
Speed	min <sup>-1</sup>	950	860	1100	910
Power consumption	W	320	235	450	330
Current draw	A	1.0	0.45	0.95	0.6
Max. back pressure	Pa	70	57	90	61
Min. ambient temperature	°C	-40	-40	-40	-40
Max. ambient temperature	°C	90	90	95	95
Starting current	A	3.8	1.2	3.5	1.1

ml = Max. load · me = Max. efficiency · fa = Free air · cs = Customer specification · ce = Customer equipment

Subject to change

### Technical description

Weight	13.7 kg
Fan size	500 mm
Rotor surface	Cast in aluminum
Terminal box material	PP plastic
Blade material	Sheet aluminum
Guard grille material	Steel, coated with black plastic (RAL 9005)
Number of blades	5
Blade pitch	0
Airflow direction	"V"
Direction of rotation	Counterclockwise, viewed toward rotor
Degree of protection	IP54
Insulation class	"F"
Moisture (F) / Environmental (H) protection class	F3-1
Max. permitted ambient temp. for motor (transport/storage)	+ 80 °C
Min. permitted ambient temp. for motor (transport/storage)	- 40 °C
Installation position	Any
Condensation drainage holes	On rotor side
Mode	S1
Motor storage	Ball bearing
Touch current according to IEC 60990 (measuring circuit Fig. 4, TN system)	<= 3.5 mA
Electrical hookup	Via terminal box
Motor protection	Thermal overload protector (TOP) externally wired
With cable	Axial
Protection class	I (with customer connection of protective earth)
Conformity with standards	EN 61800-5-1
Approval	CCC

Product drawing

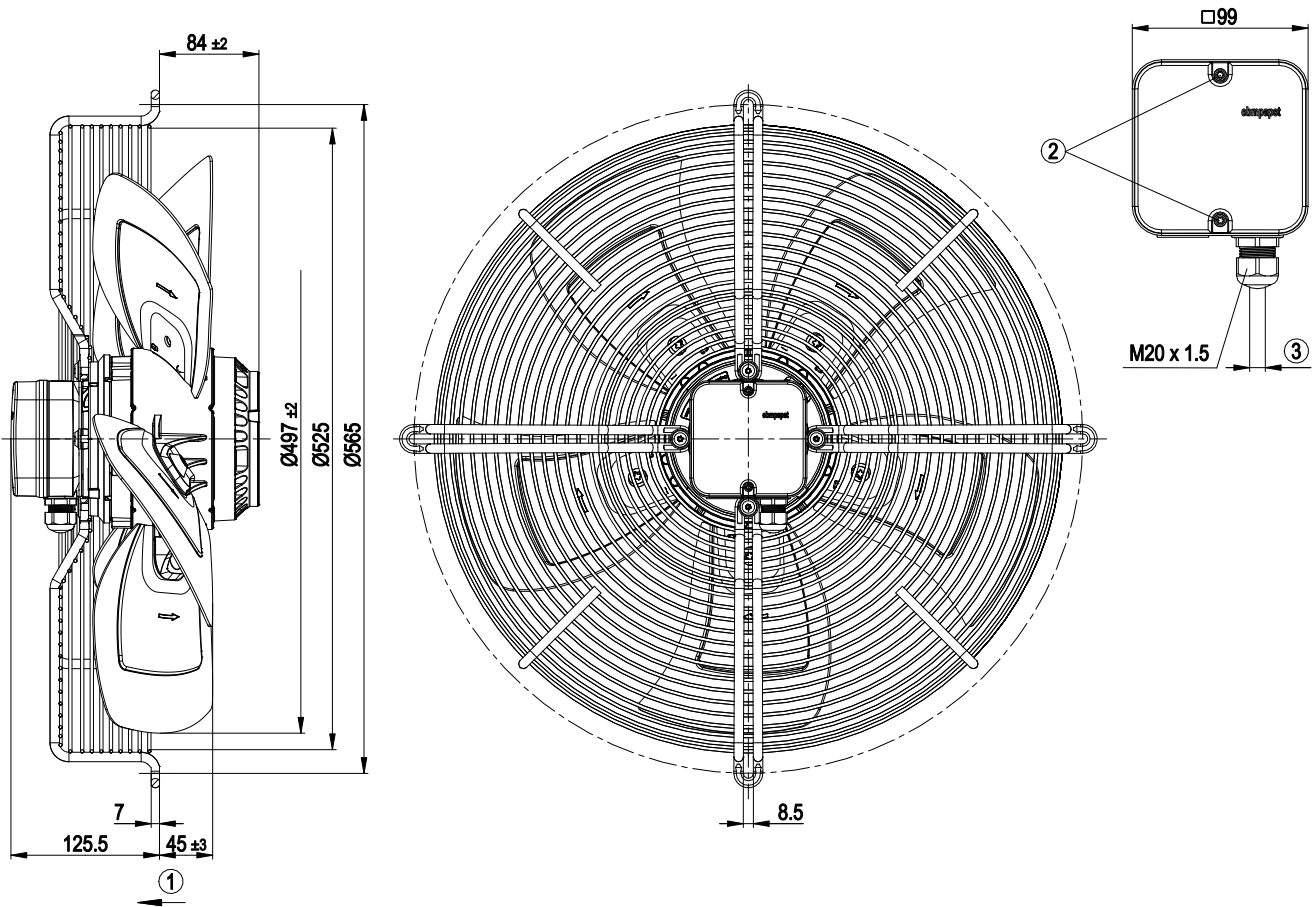

1	Direction of air flow "V"
2	Tightening torque 1.5 ± 0.2 Nm
3	Cable diameter: min. 6 mm, max. 12 mm; tightening torque 2 ± 0.3 Nm



# AC axial fan

sickle-shaped blades (S series)

## Connection diagram

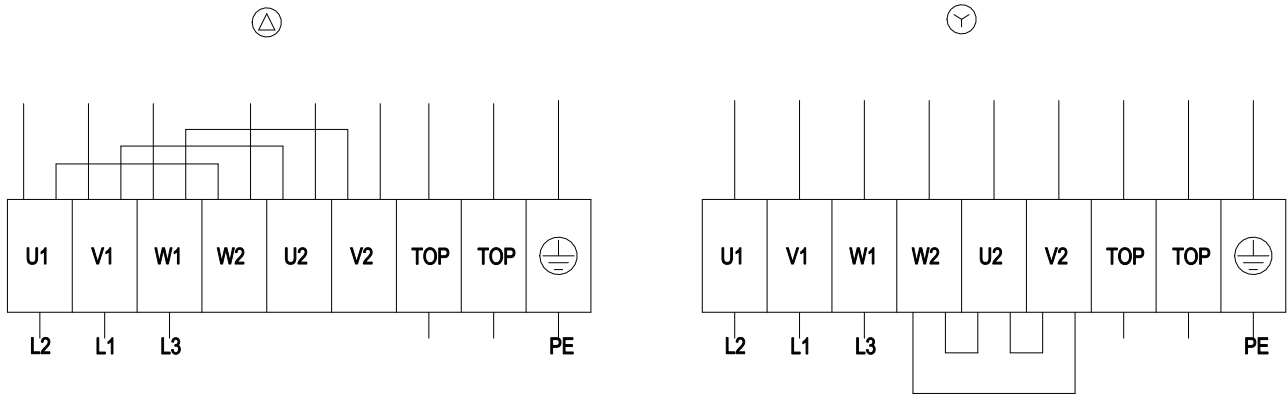

Δ	Delta connection	Y	Star connection	L1	= V1 = blue
L2	= U1 = black	L3	= W1 = brown	W2	yellow
U2	green	V2	white	TOP	2x gray
PE	green/yellow				



## Curves: Air performance 50 Hz

Line	Idno	Type	Idx	U [V]	f [Hz]	C [uF]	Ust [V]	Layout	Inst. cat.	Remark
■	5164	S6D500-AD01-09	01B	400	50			Δ	A	Rhoet 2;
◆	5159	S6D500-AD01-09	01A	400	50			Y	A	Rhoet 2;

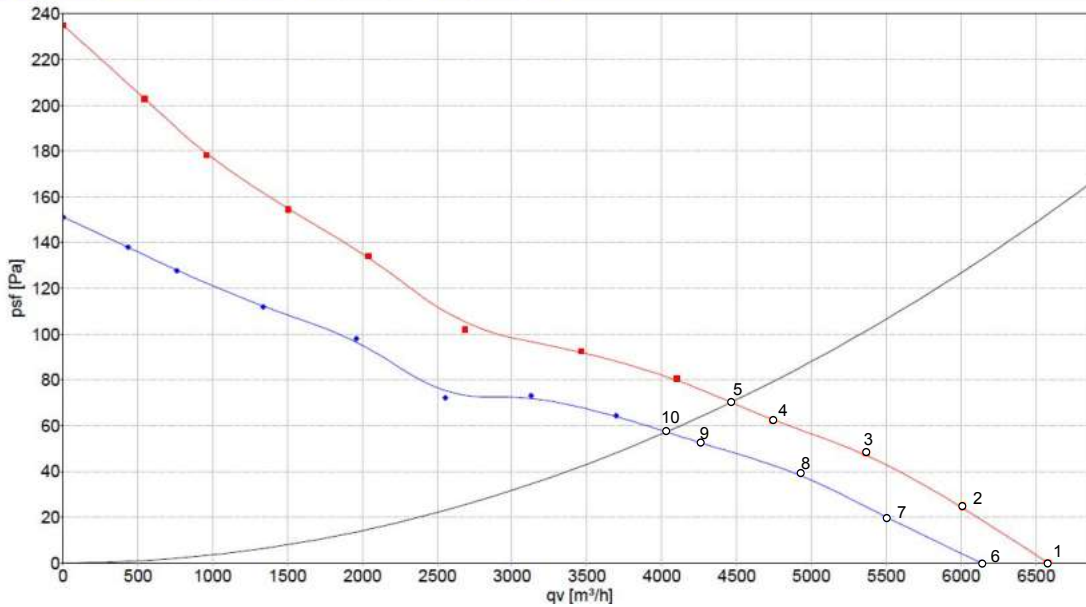

Air performance measured according to ISO 5801 installation category A. For detailed information on the measurement setup, contact ebm-papst. Intake sound level: Sound power level according to ISO 13347 / sound pressure level measured at 1 m distance from fan axis. The values given are valid under the specified measuring conditions and may vary due to conditions of installation. For deviations from the standard configuration, the parameters have to be checked on the installed unit.

## Measured values

	Conn.	U	f	n	P <sub>e</sub>	I	qv	p <sub>fs</sub>
		V	Hz	min <sup>-1</sup>	W	A	m <sup>3</sup> /h	Pa
1	Δ	400	50	965	265	0.94	6577	0
2	Δ	400	50	960	283	0.95	6010	25
3	Δ	400	50	957	301	0.96	5366	48
4	Δ	400	50	954	312	0.96	4741	62
5	Δ	400	50	950	320	1.0	4460	70
6	Y	400	50	894	194	0.38	6132	0
7	Y	400	50	882	209	0.40	5503	20
8	Y	400	50	872	224	0.42	4925	39
9	Y	400	50	865	232	0.43	4259	53
10	Y	400	50	860	235	0.45	4012	57

Conn. = Connection · U = Supply voltage · f = Frequency · n = Speed · P<sub>e</sub> = Power input · I = Current draw · LpA<sub>in</sub> = Sound pressure level inlet side · LwA<sub>in</sub> = Sound power level inlet side  
 LwA<sub>out</sub> = Sound power level outlet side · qv = Air flow · p<sub>fs</sub> = Pressure increase



## Curves: Air performance 60 Hz

Line	Idno	Type	Idx	U [V]	f [Hz]	C [µF]	Ust [V]	Layout	Inst. cat.	Remark
■	5165	S6D500-AD01-09	01C	400	60			Δ	A	Rho=1.2
●	5161	S6D500-AD01-09	01B	400	60			Y	A	Rho=1.2

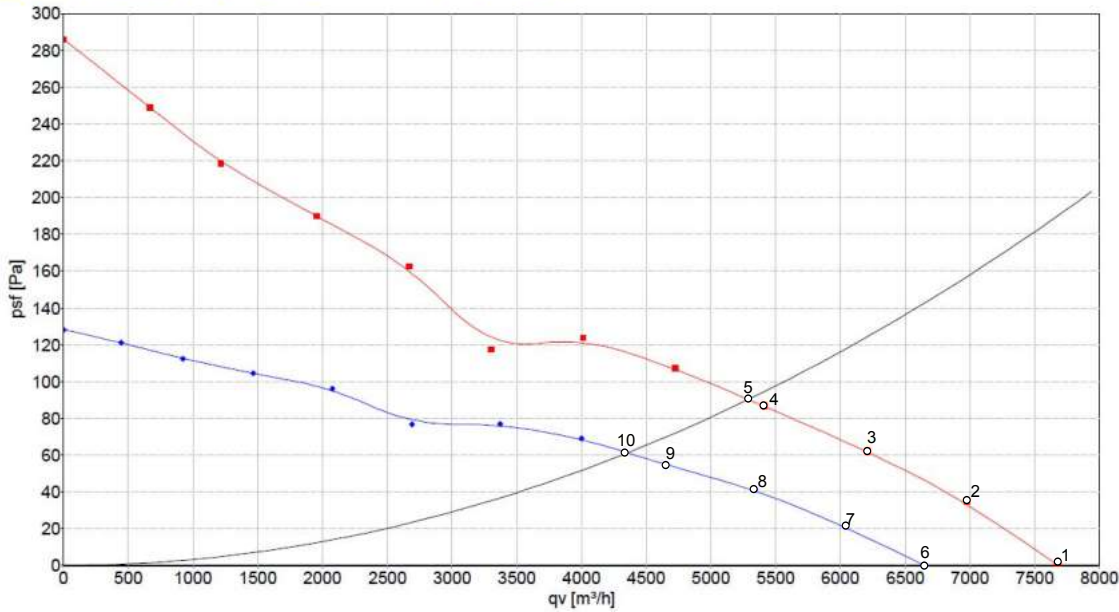

Air performance measured according to ISO 5801 installation category A. For detailed information on the measurement setup, contact ebm-papst. Intake sound level: Sound power level according to ISO 13347 / sound pressure level measured at 1 m distance from fan axis. The values given are valid under the specified measuring conditions and may vary due to conditions of installation. For deviations from the standard configuration, the parameters have to be checked on the installed unit.

## Measured values

	Conn.	U	f	n	P <sub>e</sub>	I	qv	p <sub>fs</sub>
		V	Hz	min <sup>-1</sup>	W	A	m <sup>3</sup> /h	Pa
1	Δ	400	60	1128	361	0.84	7679	0
2	Δ	400	60	1119	398	0.88	6977	35
3	Δ	400	60	1112	422	0.90	6206	62
4	Δ	400	60	1106	446	0.93	5411	87
5	Δ	400	60	1100	450	0.95	5287	90
6	Y	400	60	982	277	0.50	6648	0
7	Y	400	60	952	301	0.54	6038	21
8	Y	400	60	933	314	0.56	5341	41
9	Y	400	60	914	326	0.58	4651	55
10	Y	400	60	910	330	0.60	4360	61

Conn. = Connection · U = Supply voltage · f = Frequency · n = Speed · P<sub>e</sub> = Power input · I = Current draw · Lp<sub>Ain</sub> = Sound pressure level inlet side · Lw<sub>Ain</sub> = Sound power level inlet side  
 Lw<sub>Aout</sub> = Sound power level outlet side · qv = Air flow · p<sub>fs</sub> = Pressure increase

