

AC axial fan

straight blades (A series)

with guard grille for full nozzle

S4S300-BA02-01 ebmpapst Datasheet

sales@fansco.com

www.fansco.com

Limited partnership · Headquarters Mulfingen

Amtsgericht (court of registration) Stuttgart · HRA 590344

General partner Elektrobau Mulfingen GmbH · Headquarters Mulfingen

Amtsgericht (court of registration) Stuttgart · HRB 590142

Nominal data

Type	S4S300-BA02-01		
Motor	M4S068-DF		
Phase		1~	1~
Nominal voltage	VAC	230	230
Frequency	Hz	50	60
Method of obtaining data		fa	fa
Valid for approval/standard		CE	CE
Speed (rpm)	min ⁻¹	1380	1550
Power consumption	W	94	94
Current draw	A	0.67	0.67
Max. back pressure	Pa	75	60
Max. back pressure	inH ₂ O	0.3	0.24
Min. ambient temperature	°C	-25	-25
Max. ambient temperature	°C	30	40

ml = Max. load · me = Max. efficiency · fa = Free air · cs = Customer specification · ce = Customer equipment
Subject to change



AC axial fan

straight blades (A series)
with guard grille for full nozzle

Technical description

Weight	2.8 kg
Fan size	300 mm
Rotor surface	Painted black
Impeller material	Sheet steel, painted black
Guard grille material	Steel, phosphated and coated with black plastic
Number of blades	5
Airflow direction	"V"
Direction of rotation	Counterclockwise, viewed toward rotor
Degree of protection	IP44; installation- and position-dependent as per EN 60034-5
Insulation class	"B"
Moisture (F) / Environmental (H) protection class	H0+
Max. permitted ambient temp. for motor (transport/storage)	+ 80 °C
Min. permitted ambient temp. for motor (transport/storage)	- 40 °C
Installation position	Shaft horizontal or rotor on bottom; rotor on top on request
Condensation drainage holes	On rotor side
Mode	S1
Motor bearing	Ball bearing
Touch current according to IEC 60990 (measuring circuit Fig. 4, TN system)	< 0.75 mA
Motor protection	Thermal overload protector (TOP) internally connected
With cable	Lateral
Protection class	I (with customer connection of protective earth)
Conformity with standards	EN 60335-1; CE
Approval	CCC



AC axial fan

straight blades (A series)
with guard grille for full nozzle

Product drawing

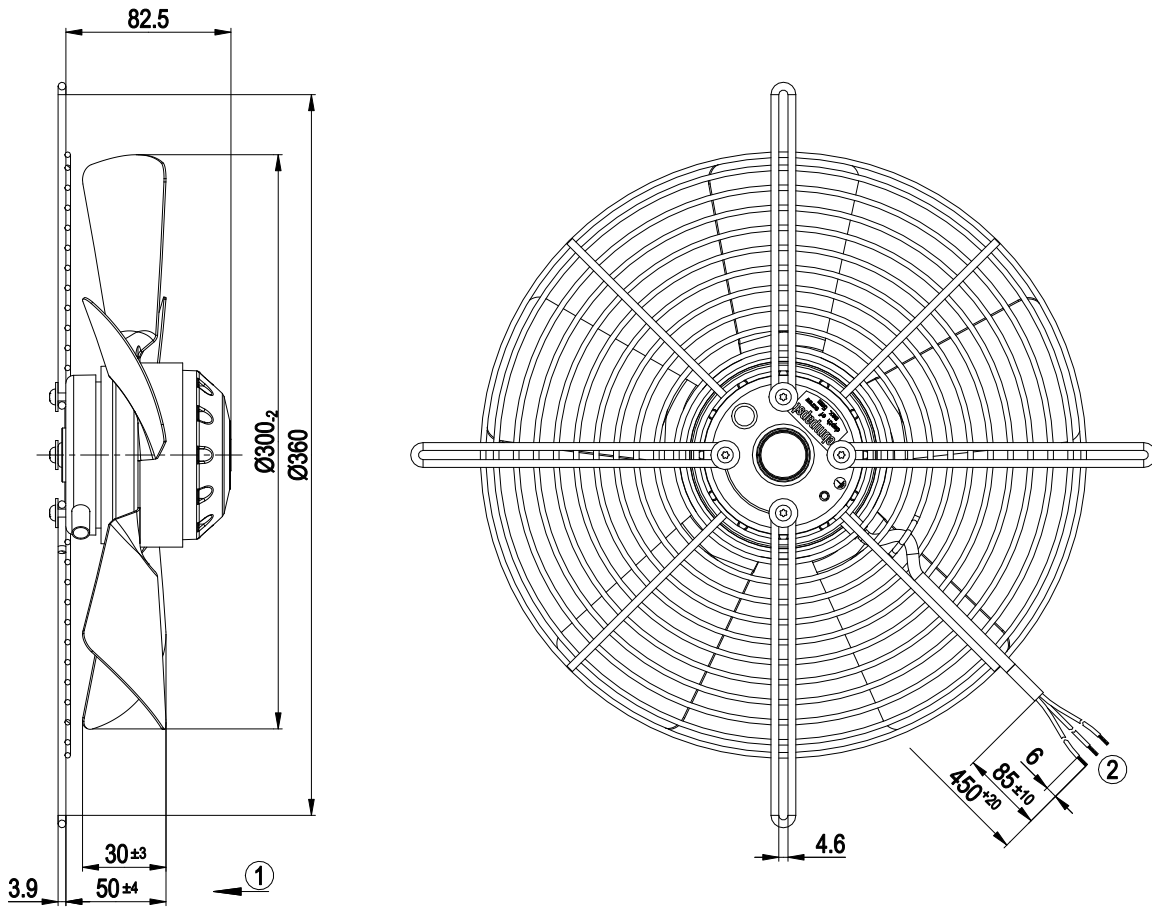

1	Airflow direction "V"
2	Cable PVC 3G 0.5 mm ² , 3x crimped splices

Connection diagram

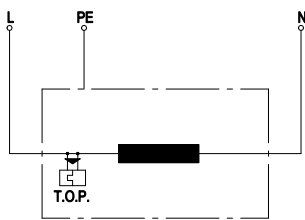

L	= blue
PE	= green/yellow
N	= brown
TOP	= thermal overload protector



AC axial fan

straight blades (A series)
with guard grille for full nozzle

Curves: Air performance 50 Hz

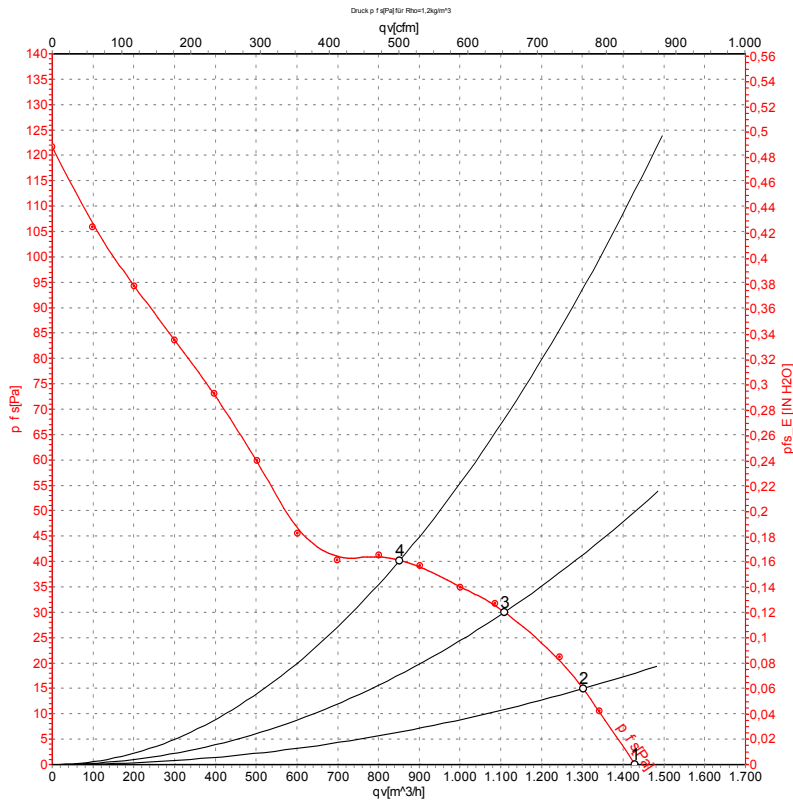

Measurement: LU-64904-1

Air performance measured according to ISO 5801 installation category A. For detailed information on the measurement setup, contact ebmpapst. Intake sound level: Sound power level according to ISO 13347 / sound pressure level measured at 1 m distance from fan axis. The values given are valid under the specified measuring conditions and may vary due to conditions of installation. For deviations from the standard configuration, the parameters have to be checked on the installed unit.

Measured values

	U	f	n	P _e	I	q _v	P _{fs}	q _v	P _{fs}
	V	Hz	min ⁻¹	W	A	m ³ /h	Pa	cfm	inH ₂ O
1	230	50	1380	86	0.67	1430	0	840	0.00
2	230	50	1365	88	0.65	1300	15	765	0.06
3	230	50	1355	88	0.64	1110	30	655	0.12
4	230	50	1355	88	0.64	850	40	500	0.16

U = Power supply · f = Frequency · n = Speed (rpm) · P_e = Power consumption · I = Current draw · q_v = Air flow · P_{fs} = Pressure increase



AC axial fan

straight blades (A series)
with guard grille for full nozzle

Curves: Air performance 60 Hz

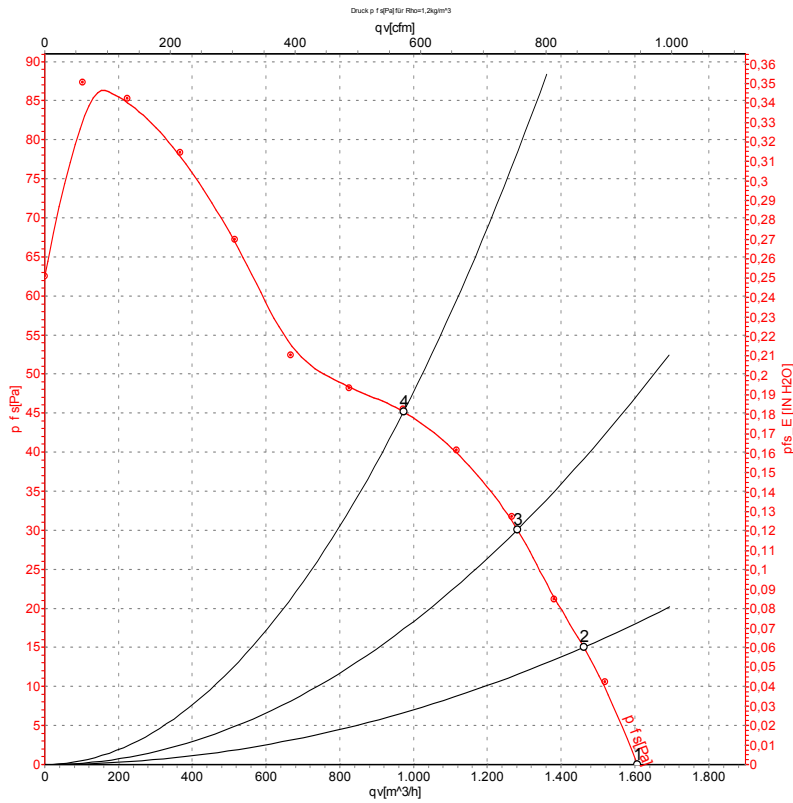

Measurement: LU-64905-1

Air performance measured according to ISO 5801 installation category A. For detailed information on the measurement setup, contact ebmpapst. Intake sound level: Sound power level according to ISO 13347 / sound pressure level measured at 1 m distance from fan axis. The values given are valid under the specified measuring conditions and may vary due to conditions of installation. For deviations from the standard configuration, the parameters have to be checked on the installed unit.

Measured values

	U	f	n	P _e	I	q _v	P _{is}	q _v	P _{is}
	V	Hz	min ⁻¹	W	A	m ³ /h	Pa	cfm	inH ₂ O
1	230	60	1550	84	0.59	1605	0	945	0.00
2	230	60	1505	88	0.61	1460	15	860	0.06
3	230	60	1475	91	0.63	1280	30	755	0.12
4	230	60	1465	92	0.63	975	45	575	0.18

U = Power supply · f = Frequency · n = Speed (rpm) · P_e = Power consumption · I = Current draw · q_v = Air flow · P_{is} = Pressure increase

