

AC axial fan

sickle-shaped blades (S series)
with guard grille for short nozzle

S4S200-AH04-01 ebmpapst Datasheet

sales@fansco.com

www.fansco.com

Limited partnership · Headquarters Mulfingen

Amtsgericht (court of registration) Stuttgart · HRA 590344

General partner Elektrobau Mulfingen GmbH · Headquarters Mulfingen

Amtsgericht (court of registration) Stuttgart · HRB 590142

Nominal data

Type	S4S200-AH04-01		
Motor	M4S068-BF		
Phase		1~	1~
Nominal voltage	VAC	230	230
Frequency	Hz	50	60
Method of obtaining data		fa	fa
Valid for approval/standard		CE	CE
Speed (rpm)	min ⁻¹	1370	1580
Power consumption	W	30	27
Current draw	A	0.21	0.19
Max. back pressure	Pa	50	50
Max. back pressure	inH ₂ O	0.2	0.2
Min. ambient temperature	°C	-25	-25
Max. ambient temperature	°C	75	80
Starting current	A	0.3	0.25

ml = Max. load · me = Max. efficiency · fa = Free air · cs = Customer specification · ce = Customer equipment

Subject to change



AC axial fan

sickle-shaped blades (S series)
with guard grille for short nozzle

Technical description

Weight	1.2 kg
Fan size	200 mm
Rotor surface	Painted black
Blade material	Sheet steel, painted black
Guard grille material	Steel, phosphated and coated with black plastic
Number of blades	9
Airflow direction	"V"
Direction of rotation	Counterclockwise, viewed toward rotor
Degree of protection	IP44
Insulation class	"B"
Moisture (F) / Environmental (H) protection class	H0+
Max. permitted ambient temp. for motor (transport/storage)	+ 80 °C
Min. permitted ambient temp. for motor (transport/storage)	- 40 °C
Installation position	Shaft horizontal or rotor on bottom; rotor on top on request
Condensation drainage holes	On rotor side
Mode	S1
Motor bearing	Ball bearing
Touch current according to IEC 60990 (measuring circuit Fig. 4, TN system)	< 0.75 mA
Motor protection	Thermal overload protector (TOP) internally connected
With cable	Lateral
Protection class	I (with customer connection of protective earth)
Conformity with standards	EN 60335-1; CE



AC axial fan

sickle-shaped blades (S series)
with guard grille for short nozzle

Product drawing

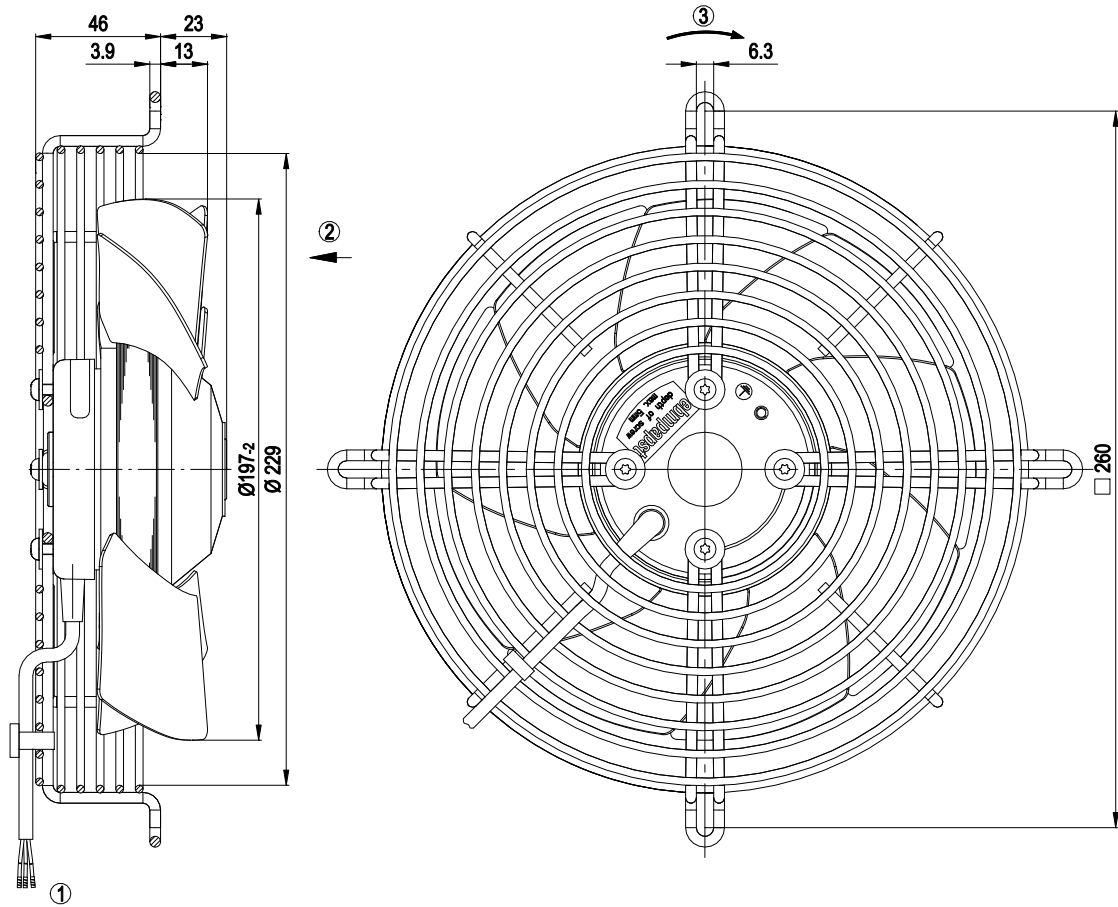

- | | |
|---|---|
| 1 | Cable PVC, 3x crimped splices |
| 2 | Direction of air flow "V" |
| 3 | Direction of rotation counterclockwise, viewed toward rotor |

Connection diagram

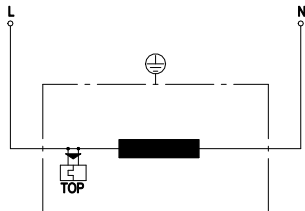

- | | |
|-----|----------------------------|
| L | = blue |
| N | = brown |
| TOP | Thermal overload protector |



AC axial fan

sickle-shaped blades (S series)
with guard grille for short nozzle

Curves: Air performance 50 Hz

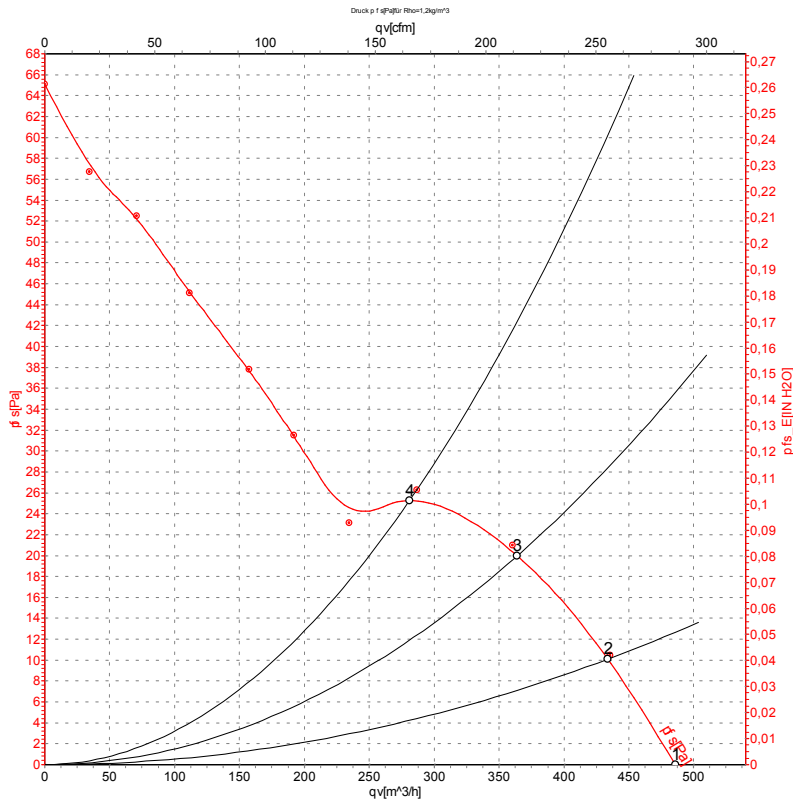

Measurement: LU-57239-1

Air performance measured according to ISO 5801 installation category A. For detailed information on the measurement setup, contact ebm-papst. Intake sound level: Sound power level according to ISO 13347 / sound pressure level measured at 1 m distance from fan axis. The values given are valid under the specified measuring conditions and may vary due to conditions of installation. For deviations from the standard configuration, the parameters have to be checked on the installed unit.

Measured values

	U	f	n	P _e	I	qv	p _{fs}	qv	p _{fs}
	V	Hz	min ⁻¹	W	A	m ³ /h	Pa	CFM	inH2O
1	230	50	1345	30	0.21	485	0	285	0.00
2	230	50	1330	31	0.22	435	10	255	0.04
3	230	50	1315	31	0.22	365	20	215	0.08
4	230	50	1310	31	0.22	280	26	165	0.10

U = Power supply · f = Frequency · n = Speed (rpm) · P_e = Power consumption · I = Current draw · qv = Air flow · p_{fs} = Pressure increase



AC axial fan

sickle-shaped blades (S series)
with guard grille for short nozzle

Curves: Air performance 60 Hz

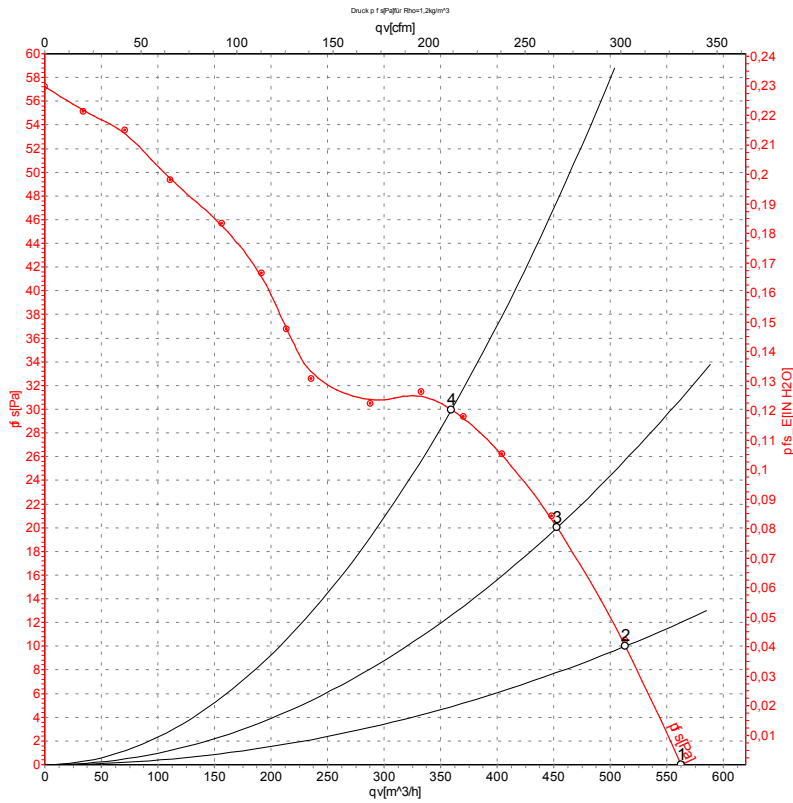

Measurement: LU-57240-1

Air performance measured according to ISO 5801 installation category A. For detailed information on the measurement setup, contact ebm-papst. Intake sound level: Sound power level according to ISO 13347 / sound pressure level measured at 1 m distance from fan axis. The values given are valid under the specified measuring conditions and may vary due to conditions of installation. For deviations from the standard configuration, the parameters have to be checked on the installed unit.

Measured values

	U	f	n	P _e	I	q _v	p _{fs}	q _v	p _{fs}
	V	Hz	min ⁻¹	W	A	m ³ /h	Pa	CFM	inH ₂ O
1	230	60	1540	27	0.19	565	0	330	0.00
2	230	60	1510	28	0.19	515	10	300	0.04
3	230	60	1485	29	0.19	455	20	265	0.08
4	230	60	1450	30	0.20	360	30	210	0.12

U = Power supply · f = Frequency · n = Speed (rpm) · P_e = Power consumption · I = Current draw · q_v = Air flow · p_{fs} = Pressure increase

