

# AC axial fan - HyBlade

sickle-shaped blades (S series)

with guard grille for short nozzle

S4E560-AQ01-02 ebmpapst Datasheet

sales@fansco.com

www.fansco.com

Limited partnership · Headquarters Mulfingen

Amtsgericht (court of registration) Stuttgart · HRA 590344

General partner Elektrobau Mulfingen GmbH · Headquarters Mulfingen

Amtsgericht (court of registration) Stuttgart · HRB 590142

## Nominal data

Type	S4E560-AQ01-02	
Motor	M4E110-IA	
Phase		1~
Nominal voltage	VAC	230
Frequency	Hz	50
Method of obtaining data		ml
Valid for approval/standard		-
Speed (rpm)	min <sup>-1</sup>	1275
Power consumption	W	1090
Current draw	A	4.76
Capacitor	µF	20
Capacitor voltage	VDB	450
Max. back pressure	Pa	160
Max. back pressure	inH <sub>2</sub> O	0.64
Min. ambient temperature	°C	-40
Max. ambient temperature	°C	55

ml = Max. load · me = Max. efficiency · fa = Free air · cs = Customer specification · ce = Customer equipment  
Subject to change



# AC axial fan - HyBlade

sickle-shaped blades (S series)

with guard grille for short nozzle

## Technical description

Weight	17.1 kg
Fan size	560 mm
Rotor surface	Cast in aluminum
Terminal box material	PP plastic
Blade material	Sheet aluminum insert, sprayed with PP plastic
Guard grille material	Steel, coated with black plastic (RAL 9005)
Number of blades	5
Blade pitch	-5°
Airflow direction	"A"
Direction of rotation	Clockwise, viewed toward rotor
Degree of protection	IP54
Insulation class	"F"
Moisture (F) / Environmental (H) protection class	F3-1
Max. permitted ambient temp. for motor (transport/storage)	+ 80 °C
Min. permitted ambient temp. for motor (transport/storage)	- 40 °C
Installation position	Shaft horizontal or rotor on bottom; rotor on top on request
Condensation drainage holes	On rotor side
Mode	S1
Motor bearing	Ball bearing
Touch current according to IEC 60990 (measuring circuit Fig. 4, TN system)	<= 3.5 mA
Electrical hookup	Via terminal box, capacitor integrated and connected
Motor protection	Thermal overload protector (TOP) with basic insulation
With cable	Axial
Protection class	I (with customer connection of protective earth)
Motor capacitor according to EN 60252-1 in safety protection class	S0
Conformity with standards	EN 61800-5-1
Approval	VDE; EAC



# AC axial fan - HyBlade

sickle-shaped blades (S series)  
with guard grille for short nozzle

## Product drawing

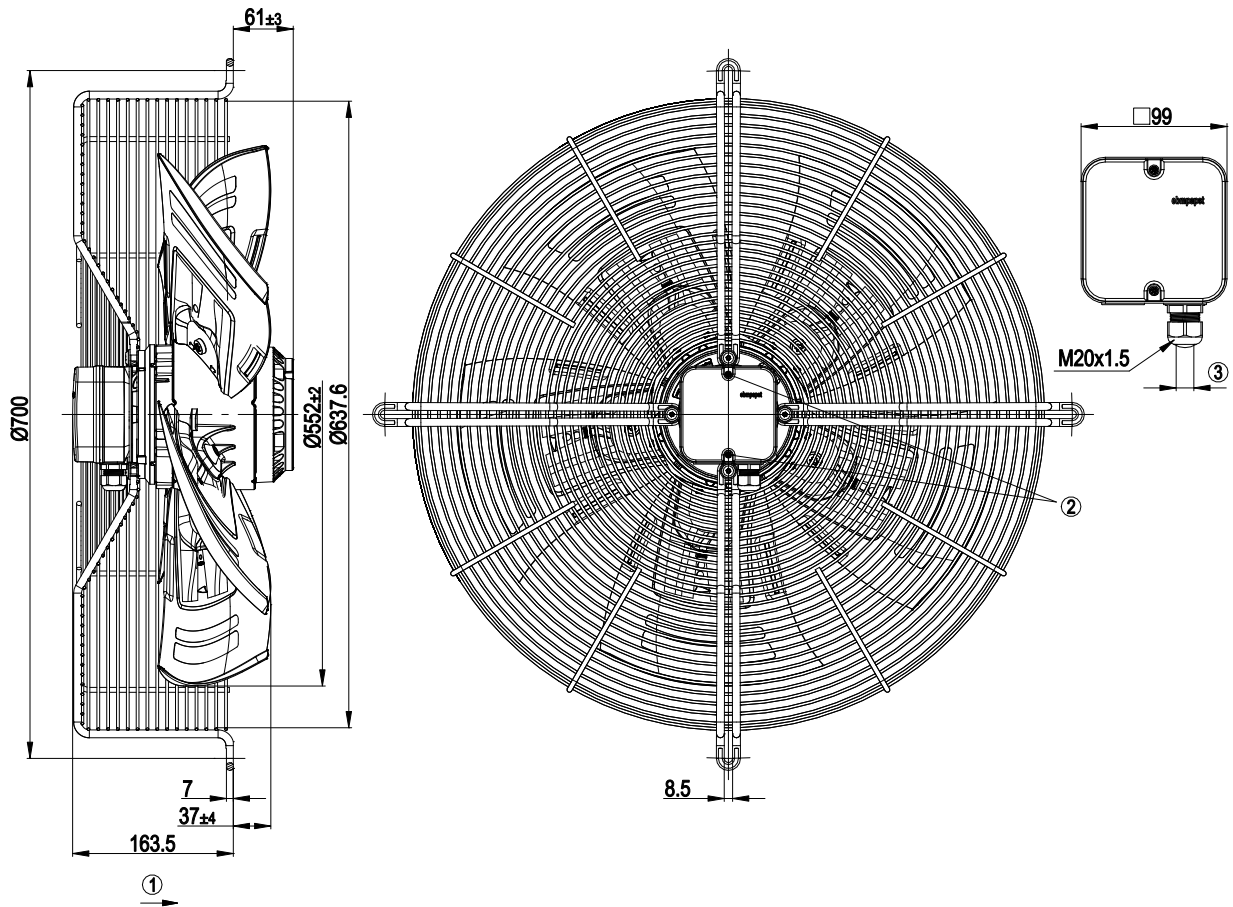

1	Direction of air flow "A"
2	Tightening torque $1.5 \pm 0.2$ Nm
3	Cable diameter min. 6 mm, max. 12 mm, tightening torque $2 \pm 0.3$ Nm



# AC axial fan - HyBlade

sickle-shaped blades (S series)  
with guard grille for short nozzle

## Connection diagram



L	= U1 = blue	Z	brown	N	= U2 = black
PE	green/yellow	TOP	gray		



# AC axial fan - HyBlade

sickle-shaped blades (S series)  
with guard grille for short nozzle

## Curves: Air performance 50 Hz

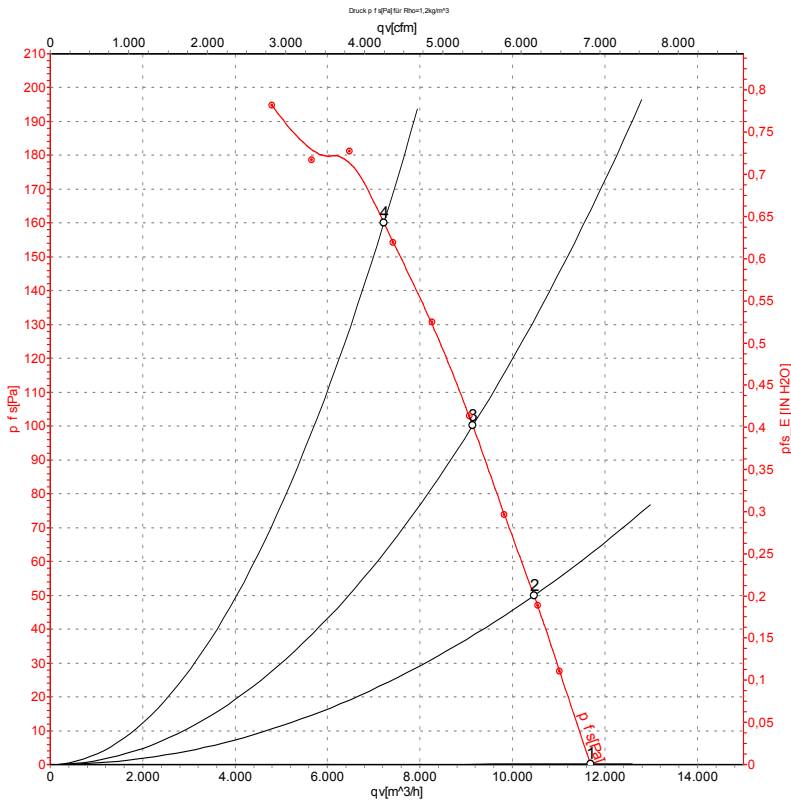

Measurement: LU-111142-1

Air performance measured according to ISO 5801 installation category A. For detailed information on the measurement setup, contact ebm-papst. Intake sound level: Sound power level according to ISO 13347 / sound pressure level measured at 1 m distance from fan axis. The values given are valid under the specified measuring conditions and may vary due to conditions of installation. For deviations from the standard configuration, the parameters have to be checked on the installed unit.

## Measured values

	U	f	n	P <sub>e</sub>	I	LpA <sub>in</sub>	LwA <sub>in</sub>	LwA <sub>out</sub>	q <sub>v</sub>	p <sub>fs</sub>	q <sub>v</sub>	p <sub>fs</sub>
	V	Hz	min <sup>-1</sup>	W	A	dB(A)	dB(A)	dB(A)	m <sup>3</sup> /h	Pa	cfm	inH <sub>2</sub> O
1	230	50	1370	872	3.81	69	76	77	11690	0	6880	0.00
2	230	50	1340	951	4.15	68	75	76	10470	50	6160	0.20
3	230	50	1315	1017	4.44	66	73	74	9140	100	5380	0.40
4	230	50	1275	1090	4.76	69	76	76	7220	160	4250	0.64

U = Power supply · f = Frequency · n = Speed (rpm) · P<sub>e</sub> = Power consumption · I = Current draw · LpA<sub>in</sub> = Sound pressure level intake side · LwA<sub>in</sub> = Sound power level intake side  
LwA<sub>out</sub> = Sound power level outlet side · q<sub>v</sub> = Air flow · p<sub>fs</sub> = Pressure increase

