

# AC axial fan

sickle-shaped blades (S series)  
with guard grille for short nozzle

S4E450-AU03-38 ebmpapst Datasheet  
sales@fansco.com  
www.fansco.com

Limited partnership · Headquarters Mulfingen  
Amtsgericht (court of registration) Stuttgart · HRA 590344  
General partner Elektrobau Mulfingen GmbH · Headquarters Mulfingen  
Amtsgericht (court of registration) Stuttgart · HRB 590142



## Nominal data

Type	S4E450-AU03-38		
Motor	M4E094-EA		
Phase		1~	1~
Nominal voltage	VAC	230	230
Frequency	Hz	50	60
Method of obtaining data		ml	ml
Valid for approval/standard		CE	CE
Speed (rpm)	min <sup>-1</sup>	1300	1490
Power consumption	W	350	425
Current draw	A	1.55	1.87
Capacitor	µF	8	8
Capacitor voltage	VDB	450	450
Max. back pressure	Pa	120	50
Max. back pressure	inH <sub>2</sub> O	0.48	0.2
Min. ambient temperature	°C	-40	-40
Max. ambient temperature	°C	55	45
Starting current	A	6.0	5.5

ml = Max. load · me = Max. efficiency · fa = Free air · cs = Customer specification · ce = Customer equipment  
Subject to change

## Data according to ErP Directive

		Actual	Req. 2015			
01 Overall efficiency $\eta_{es}$	%	32.9	30.6	09 Power consumption $P_e$	kW	0.33
02 Measurement category		A		09 Air flow $q_v$	m <sup>3</sup> /h	3920
03 Efficiency category		Static		09 Pressure increase $p_{fs}$	Pa	100
04 Efficiency grade N		42.3	40	10 Speed (rpm) n	min <sup>-1</sup>	1325
05 Variable speed drive		No		11 Specific ratio*		1.00

Data obtained at optimum efficiency level.

The ErP data is determined using a motor-impeller combination in a standardized measurement setup.

\* Specific ratio =  $1 + p_{fs} / 100\,000\text{ Pa}$

LU-71958



# AC axial fan

sickle-shaped blades (S series)  
with guard grille for short nozzle

## Technical description

Weight	7.4 kg
Fan size	450 mm
Rotor surface	Painted black
Terminal box material	PC/ABS plastic
Blade material	Press-fitted sheet steel blank, sprayed with PP plastic
Guard grille material	Steel, coated with black plastic (RAL 9005)
Number of blades	5
Airflow direction	"V"
Direction of rotation	Counterclockwise, viewed toward rotor
Degree of protection	IP54
Insulation class	"F"
Moisture (F) / Environmental (H) protection class	F4-1
Max. permitted ambient temp. for motor (transport/storage)	+80 °C
Min. permitted ambient temp. for motor (transport/storage)	-40 °C
Installation position	Shaft horizontal or rotor on bottom; rotor on top on request
Condensation drainage holes	On rotor side
Mode	S1
Motor bearing	Ball bearing
Touch current according to IEC 60990 (measuring circuit Fig. 4, TN system)	<= 3.5 mA
Electrical hookup	Via terminal box, capacitor integrated and connected
Motor protection	Thermal overload protector (TOP) internally connected
Protection class	I (with customer connection of protective earth)
Motor capacitor according to EN 60252-1 in safety protection class	P0/S0
Conformity with standards	EN 60034-1 (2004); CE
Approval	CSA C22.2 No. 100; UL 1004-1



# AC axial fan

sickle-shaped blades (S series)  
with guard grille for short nozzle

## Product drawing

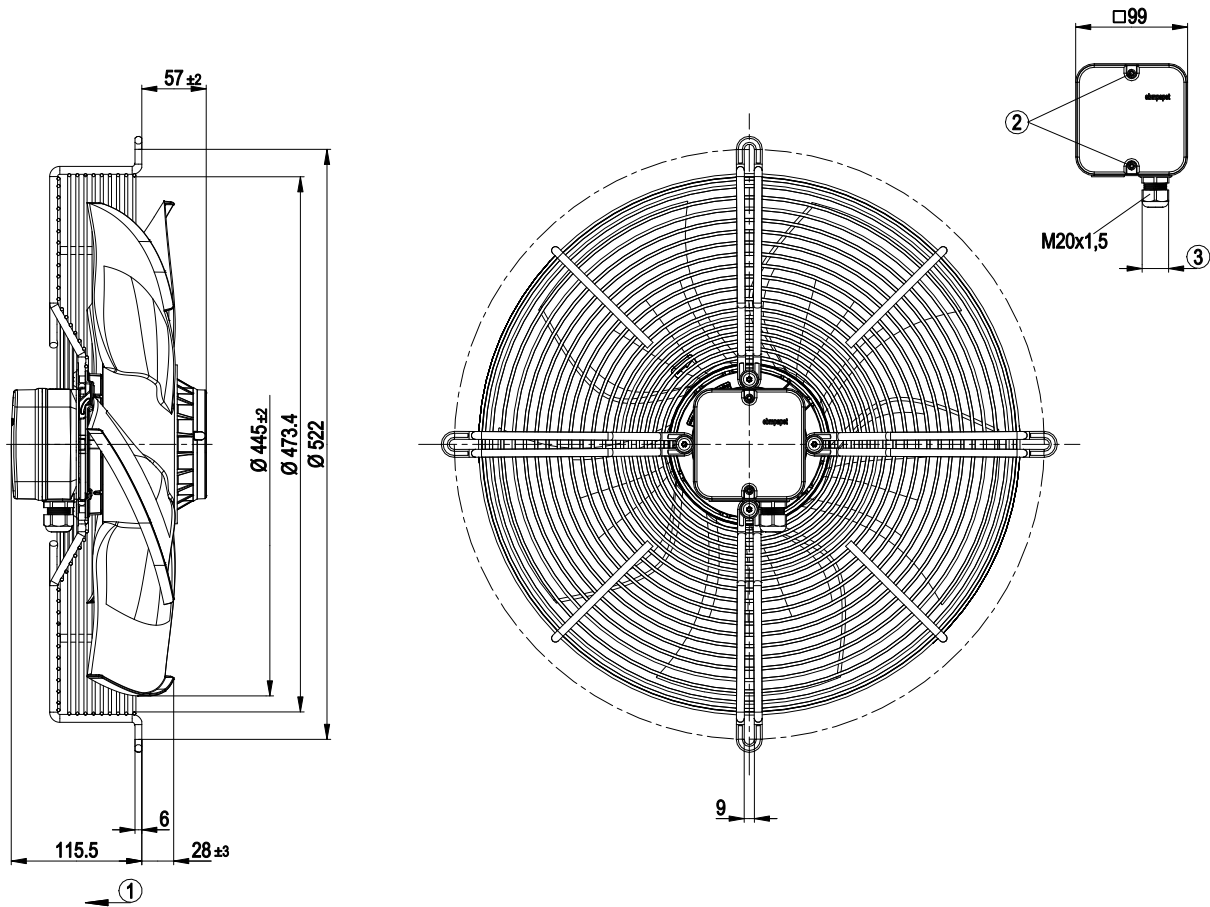

1	Direction of air flow "V"
2	Tightening torque 0.8 ± 0.15 Nm
3	Cable diameter min. 6 mm, max. 12 mm, tightening torque 2±0.2 Nm

## Connection diagram



L	= U1 = blue	Z	brown	N	= U2 = black
PE	green/yellow				



# AC axial fan

sickle-shaped blades (S series)  
with guard grille for short nozzle

## Curves: Air performance 50 Hz

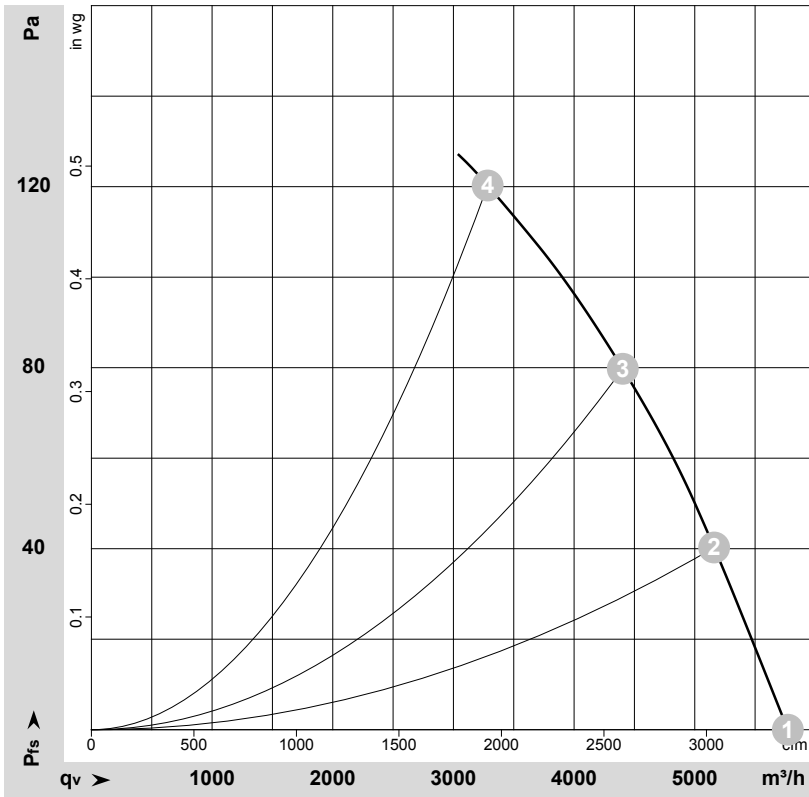

$\rho = 1.15 \text{ kg/m}^3 \pm 2 \%$

Measurement: LU-71958-1

Air performance measured according to ISO 5801 installation category A. For detailed information on the measurement setup, contact ebmpapst. Intake sound level: Sound power level according to ISO 13347 / sound pressure level measured at 1 m distance from fan axis. The values given are valid under the specified measuring conditions and may vary due to conditions of installation. For deviations from the standard configuration, the parameters have to be checked on the installed unit.

## Measured values

	U	f	n	P <sub>e</sub>	I	qv	p <sub>fs</sub>	qv	p <sub>fs</sub>
	V	Hz	min <sup>-1</sup>	W	A	m <sup>3</sup> /h	Pa	CFM	inH <sub>2</sub> O
1	230	50	1380	272	1.20	5770	0	3395	0.00
2	230	50	1355	299	1.32	5160	40	3040	0.16
3	230	50	1340	321	1.40	4405	80	2590	0.32
4	230	50	1300	350	1.55	3285	120	1935	0.48

U = Power supply · f = Frequency · n = Speed (rpm) · P<sub>e</sub> = Power consumption · I = Current draw · qv = Air flow · p<sub>fs</sub> = Pressure increase



# AC axial fan

sickle-shaped blades (S series)  
with guard grille for short nozzle

## Curves: Air performance 60 Hz

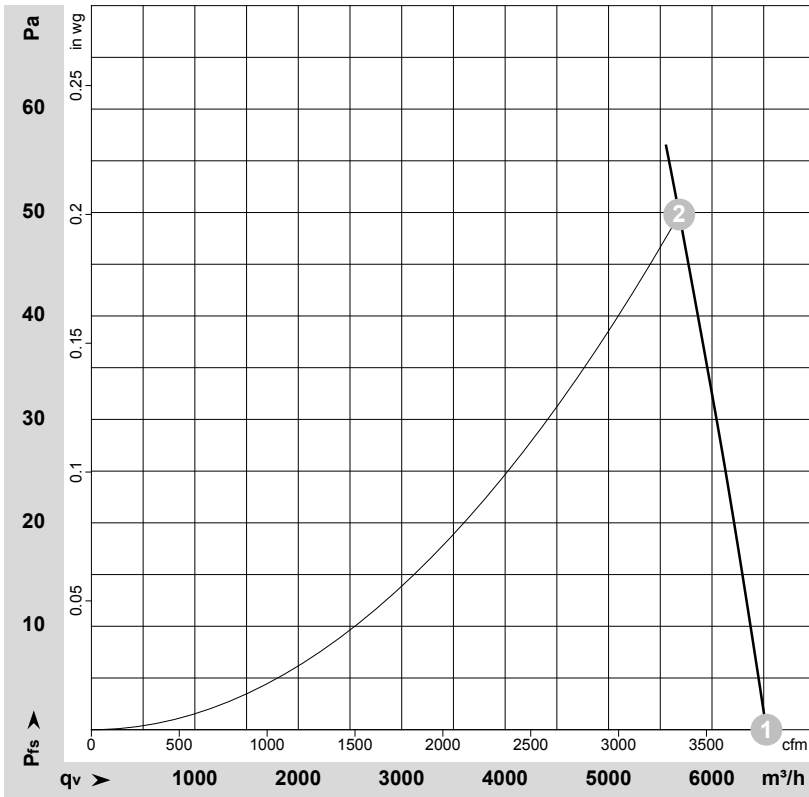

$\rho = 1.15 \text{ kg/m}^3 \pm 2 \%$

Measurement: LU-71963-1

Air performance measured according to ISO 5801 installation category A. For detailed information on the measurement setup, contact ebmpapst. Intake sound level: Sound power level according to ISO 13347 / sound pressure level measured at 1 m distance from fan axis. The values given are valid under the specified measuring conditions and may vary due to conditions of installation. For deviations from the standard configuration, the parameters have to be checked on the installed unit.

## Measured values

	U	f	n	P <sub>e</sub>	I	qv	p <sub>fs</sub>	qv	p <sub>fs</sub>
	V	Hz	min <sup>-1</sup>	W	A	m <sup>3</sup> /h	Pa	CFM	inH <sub>2</sub> O
1	230	60	1545	396	1.74	6525	0	3840	0.00
2	230	60	1490	425	1.87	5685	50	3345	0.20

U = Power supply · f = Frequency · n = Speed (rpm) · P<sub>e</sub> = Power consumption · I = Current draw · qv = Air flow · p<sub>fs</sub> = Pressure increase

