

AC axial fan

sickled blades (S series)
with guard grille for short nozzle

S4E450-AP01-06 ebmpapst Datasheet

sales@fansco.com

www.fansco.com

Nominal data

Type	S4E450-AP01-06		
Motor	M4E074-GA		
Phase		1~	1~
Nominal voltage	VAC	230	230
Frequency	Hz	50	60
Type of data definition		fa	fa
Valid for approval / standard		CE	CE
Speed	min ⁻¹	1400	1600
Power input	W	245	355
Current draw	A	1.1	1.55
Motor capacitor	μF	8	8
Capacitor voltage	VDB	400	400
Max. back pressure	Pa	85	35
Min. ambient temperature	°C	-25	-25
Max. ambient temperature	°C	60	40
Starting current	A	2.8	2.6

ml = Max. load · me = Max. efficiency · fa = Running at free air · cs = Customer specs · cu = Customer unit
Subject to alterations

Data according to ErP directive

Installation category	A
Efficiency category	Static
Variable speed drive	No
Specific ratio*	1.00

* Specific ratio = $1 + p_g / 100\,000\text{ Pa}$

		Actual	Request 2013	Request 2015
Overall efficiency η_{es}	%	32.2	26.5	30.5
Efficiency grade N		41.7	36	40
Power input P_e	kW	0.32		
Air flow q_v	m ³ /h	3690		
Pressure increase p_{fs}	Pa	101		
Speed n	min ⁻¹	1325		

Data definition with optimum efficiency. LU-33262
The ErP data is determined using a motor-impeller combination in a standardised measurement configuration.



AC axial fan

sickled blades (S series)
with guard grille for short nozzle

Technical features

Mass	7.2 kg
Size	450 mm
Surface of rotor	Coated in black
Material of terminal box	ABS Plastic, black
Material of blades	Sheet steel, coated in black
Material of guard grille	Steel, phosphated and coated in black plastic
Number of blades	5
Direction of air flow	"V"
Direction of rotation	Counter-clockwise, seen on rotor
Type of protection	IP 44
Insulation class	"F"
Humidity class	F2-2
Max. permissible ambient motor temp. (transp./ storage)	+80 °C
Min. permissible ambient motor temp. (transp./storage)	-40 °C
Mounting position	Shaft horizontal or rotor on bottom; rotor on top on request
Condensate discharge holes	Rotor-side
Operation mode	S1
Motor bearing	Ball bearing
Touch current acc. IEC 60990 (measuring network Fig. 4, TN system)	< 0.75 mA
Electrical leads	Via terminal box, integrated capacitor connected via terminal box
Motor protection	Thermal overload protector (TOP) wired internally
Cable exit	Variable
Protection class	I (if protective earth is connected by customer)
Product conforming to standard	EN 60335-1; CE
Approval	EAC



AC axial fan

sickled blades (S series)
with guard grille for short nozzle

Product drawing

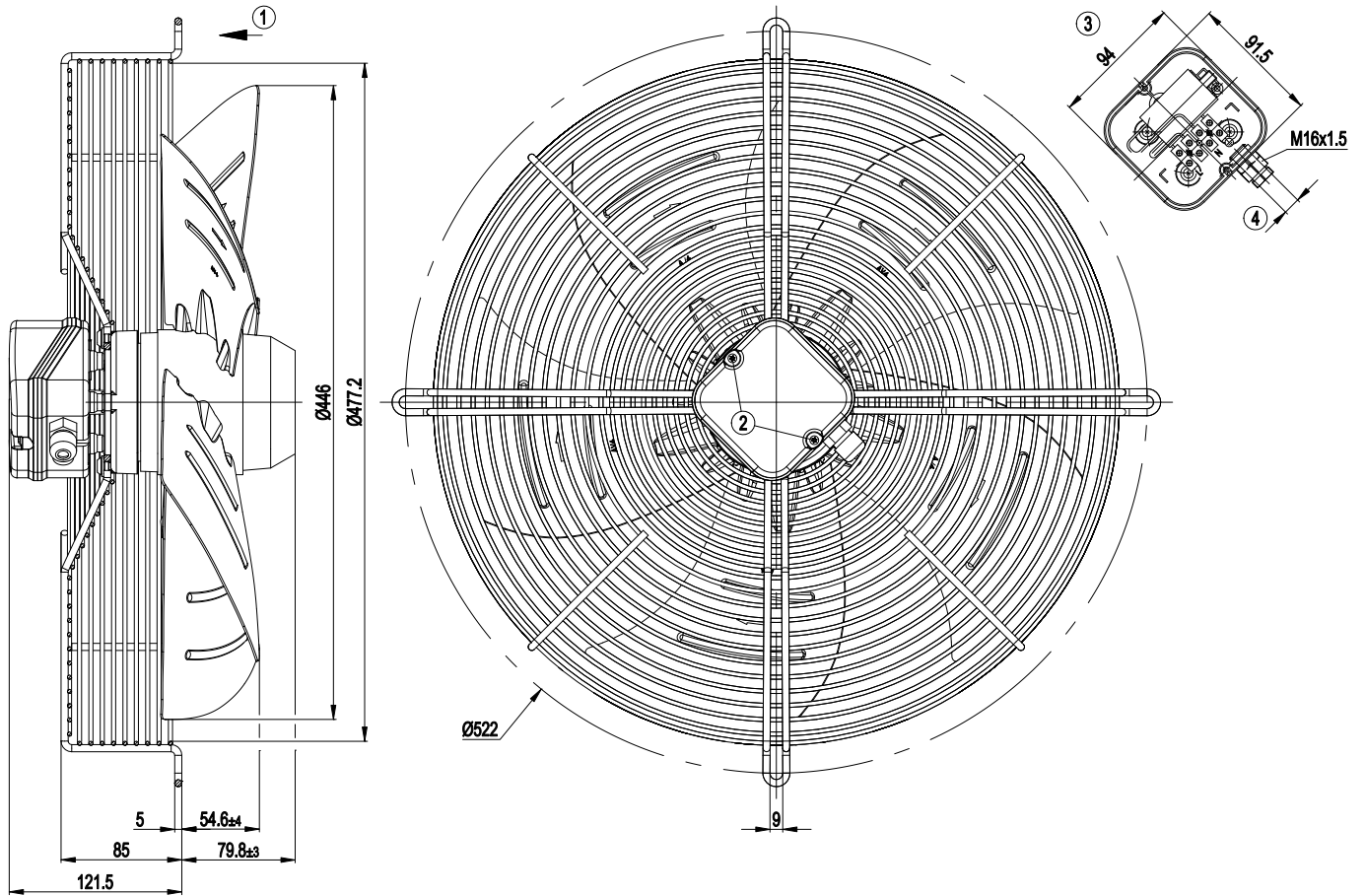

1	Direction of air flow "V"
2	Tightening torque 0.5 Nm
3	Illustration without terminal box cover
4	Cable diameter max. 7.5 mm, tightening torque 2 Nm

Connection screen

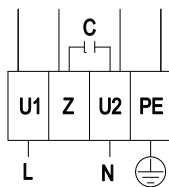

L	= U1 = blue	Z	brown	N	= U2 = black
PE	green/yellow				



AC axial fan

sickled blades (S series)
with guard grille for short nozzle

Charts: Air flow 50 Hz

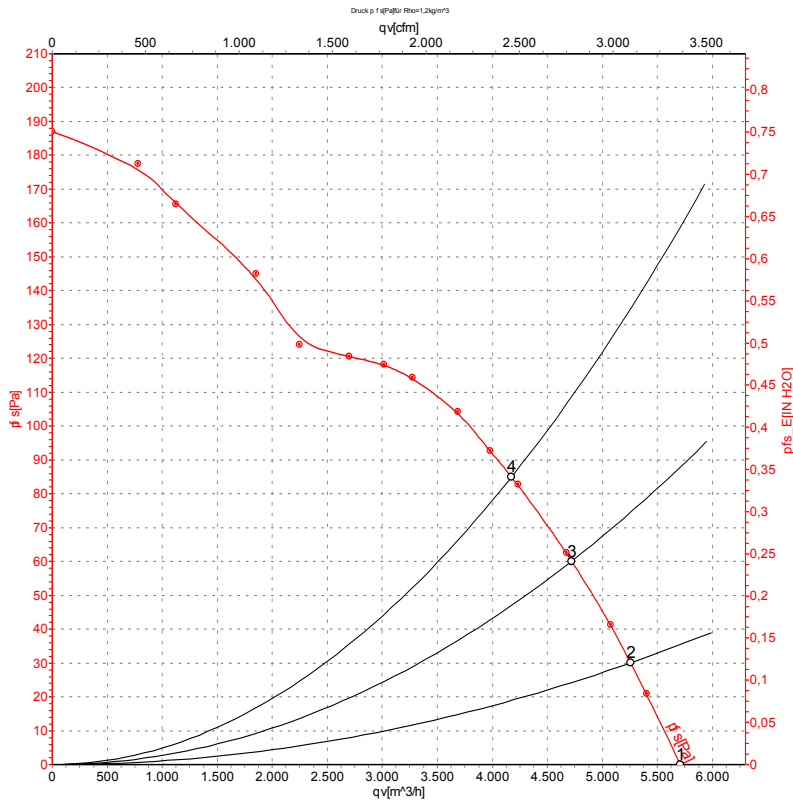

Air performance measured as per ISO 5801 Installation category A. For detailed information on the measuring set-up, please contact ebmpapst. Suction-side noise levels: L_{wA} measured as per ISO 13347 / L_{pA} measured with 1m distance to fan axis. The values given are valid under the measuring conditions mentioned above and may vary according to the actual installation situation. With any deviation from the standard set-up, the specific values have to be checked and reviewed with the unit installed.

Measured values

	U	f	n	P _e	I	qv	P _{fs}
	V	Hz	min ⁻¹	W	A	m ³ /h	Pa
1	230	50	1400	245	1.10	5705	0
2	230	50	1385	264	1.19	5255	30
3	230	50	1365	285	1.27	4720	60
4	230	50	1345	303	1.35	4175	85

U = Supply voltage · f = Frequency · n = Speed · P_e = Power input · I = Current draw · qv = Air flow · P_{fs} = Pressure increase



AC axial fan

sickled blades (S series)
with guard grille for short nozzle

Charts: Air flow 60 Hz

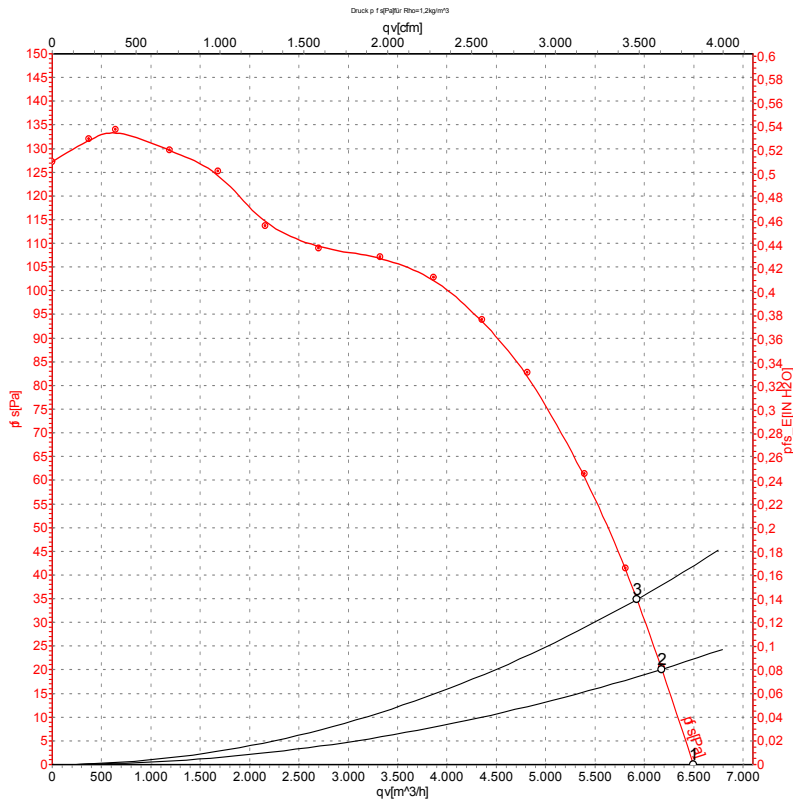

Air performance measured as per ISO 5801 Installation category A. For detailed information on the measuring set-up, please contact ebmpapst. Suction-side noise levels: L_{wA} measured as per ISO 13347 / L_{pA} measured with 1m distance to fan axis. The values given are valid under the measuring conditions mentioned above and may vary according to the actual installation situation. With any deviation from the standard set-up, the specific values have to be checked and reviewed with the unit installed.

Measured values

	U	f	n	P _e	I	qv	p _{fs}
	V	Hz	min ⁻¹	W	A	m³/h	Pa
1	230	60	1600	355	1.55	6495	0
2	230	60	1580	364	1.58	6175	20
3	230	60	1560	376	1.63	5925	35

U = Supply voltage · f = Frequency · n = Speed · P_e = Power input · I = Current draw · qv = Air flow · p_{fs} = Pressure increase

