

S4E450-AP01-02 ebmpapst Datasheet

sales@fansco.com

www.fansco.com

## Nominal data

Type	S4E450-AP01-02		
Motor	M4E074-GA		
Phase		1~	1~
Nominal voltage	VAC	230	230
Frequency	Hz	50	60
Method of obtaining data		fa	fa
Valid for approval/standard		CE	CE
Speed (rpm)	min <sup>-1</sup>	1400	1600
Power consumption	W	245	355
Current draw	A	1.1	1.55
Capacitor	μF	8	8
Capacitor voltage	VDB	400	400
Capacitor standard		S0 (CE)	S0 (CE)
Max. back pressure	Pa	85	35
Max. back pressure	in. wg	0.34	0.14
Min. ambient temperature	°C	-25	-25
Max. ambient temperature	°C	60	40
Starting current	A	2.8	2.6

ml = Max. load · me = Max. efficiency · fa = Free air · cs = Customer specification · ce = Customer equipment  
Subject to change

## Data according to Commission Regulation (EU) 327/2011 (EN 17166)

		Actual	Req. 2015			
01 Overall efficiency $\eta_{es}$	%	31.5	30.5	09 Power consumption $P_e$	kW	0.32
02 Measurement category		A		09 Air flow $q_v$	m <sup>3</sup> /h	3690
03 Efficiency category		Static		09 Pressure increase $p_{fs}$	Pa	101
04 Efficiency grade N		41	40	10 Speed (rpm) n	min <sup>-1</sup>	1325
05 Variable speed drive		No		11 Specific ratio*		1.00

Data obtained at optimum efficiency level.

The ErP data is determined using a motor-impeller combination in a standardized measurement setup.

\* Specific ratio =  $1 + p_g / 100\,000\text{ Pa}$ 

LU-33262



# AC axial fan

sickle-shaped blades (S series)  
with guard grille for short nozzle

## Technical description

Weight	7.06 kg
Size	450 mm
Motor size	74
Rotor surface	Painted black
Blade material	Sheet steel
Guard grille material	Steel, phosphated and coated with black plastic (RAL 9005)
Number of blades	5
Airflow direction	A
Direction of rotation	Clockwise, viewed toward rotor
Degree of protection	IP44; installation- and position-dependent as per EN 60034-5
Insulation class	"F"
Moisture (F) / Environmental (H) protection class	H1
Max. permitted ambient temp. for motor (transport/storage)	+ 80 °C
Min. permitted ambient temp. for motor (transport/storage)	- 40 °C
Installation position	Shaft horizontal or rotor on bottom; rotor on top on request
Condensation drainage holes	On rotor side
Mode	S1
Motor bearing	Ball bearing
Touch current according to IEC 60990 (measuring circuit Fig. 4, TN system)	< 0.75 mA
Motor protection	Thermal overload protector (TOP) internally connected
With cable	Variable
Protection class	I (with customer connection of protective earth)
Conformity with standards	EN 60335-1; CE
Approval	EAC



# AC axial fan

sickle-shaped blades (S series)  
with guard grille for short nozzle

## Product drawing

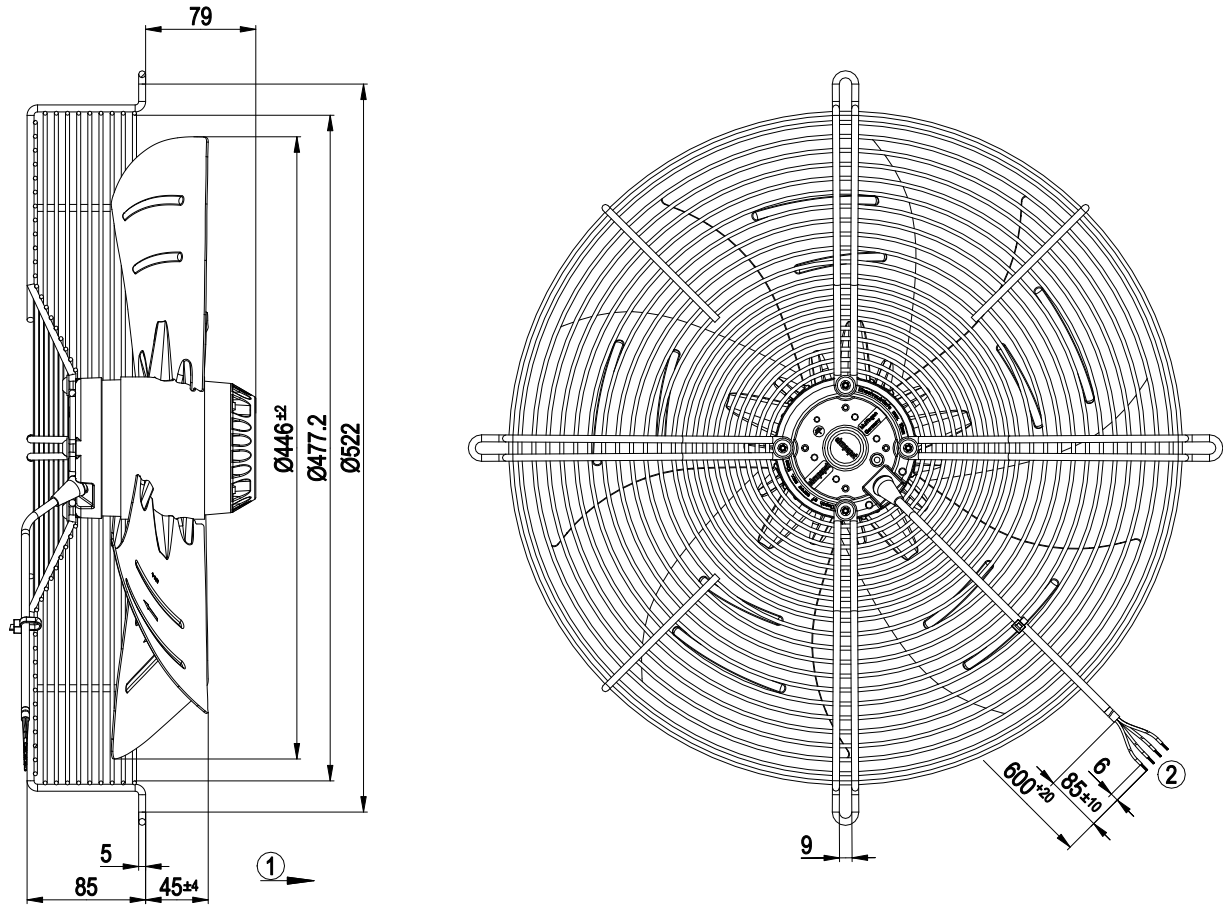

1 Direction of air flow "A"

2 Cable silicone 4G 0.5 mm<sup>2</sup>

4x splice

## Connection diagram

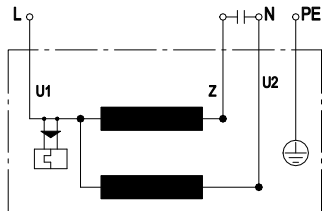

U1 blue

Z brown

U2 black

PE green/yellow



# AC axial fan

sickle-shaped blades (S series)  
with guard grille for short nozzle

## Curves: Air performance 50 Hz

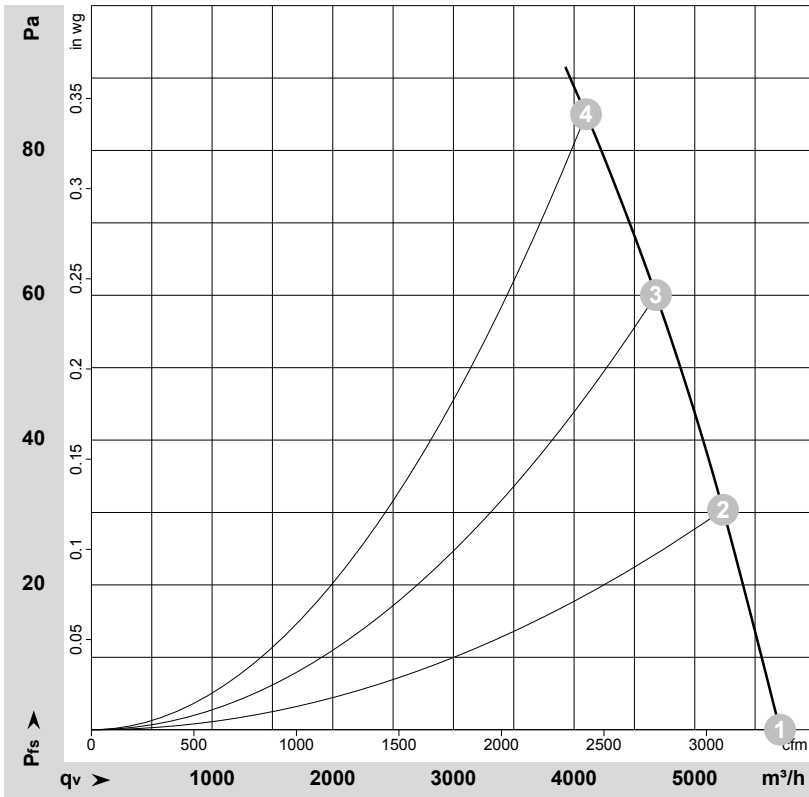

$\rho = 1.15 \text{ kg/m}^3 \pm 2 \%$

Measurement: LU-33262-1

Air performance measured according to ISO 5801 installation category A. For detailed information on the measurement setup, contact ebm-papst. Intake sound level: Sound power level according to ISO 13347 / sound pressure level measured at 1 m distance from fan axis. The values given are valid under the specified measuring conditions and may vary due to conditions of installation. For deviations from the standard configuration, the parameters have to be checked on the installed unit.

## Measured values

	U	f	n	P <sub>e</sub>	I	q <sub>v</sub>	P <sub>fs</sub>	q <sub>v</sub>	P <sub>fs</sub>
	V	Hz	min <sup>-1</sup>	W	A	m <sup>3</sup> /h	Pa	cfm	in. wg
1	230	50	1400	245	1.10	5705	0	3360	0.00
2	230	50	1385	265	1.19	5235	30	3080	0.12
3	230	50	1365	286	1.28	4680	60	2755	0.24
4	230	50	1340	306	1.36	4100	85	2415	0.34

U = Voltage · f = Frequency · n = Speed (rpm) · P<sub>e</sub> = Power consumption · I = Current draw · q<sub>v</sub> = Air flow · P<sub>fs</sub> = Pressure increase



# AC axial fan

sickle-shaped blades (S series)  
with guard grille for short nozzle

## Curves: Air performance 60 Hz

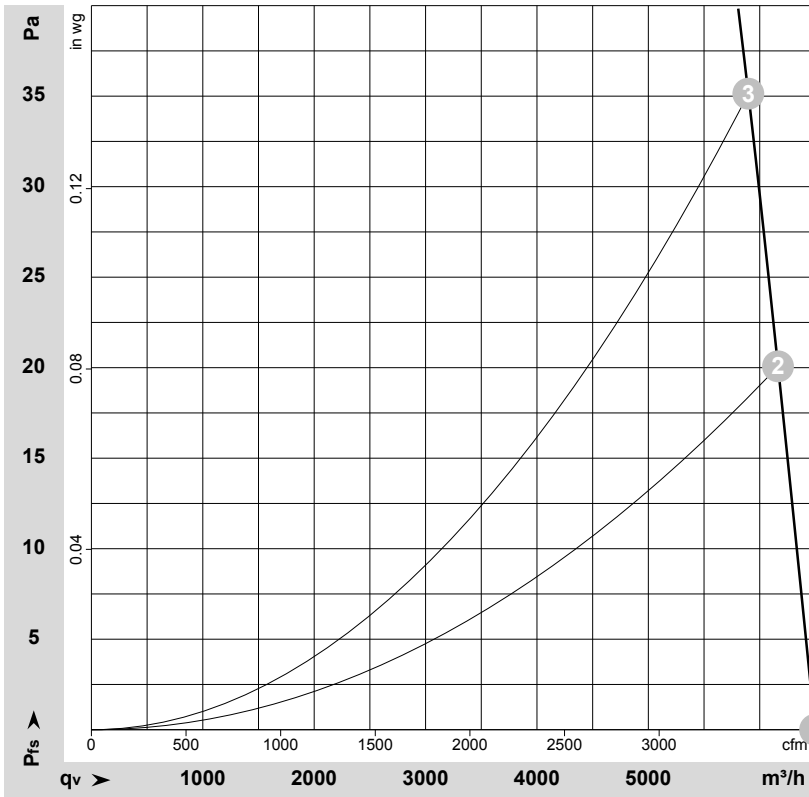

$\rho = 1.15 \text{ kg/m}^3 \pm 2 \%$

Measurement: LU-33263-1

Air performance measured according to ISO 5801 installation category A. For detailed information on the measurement setup, contact ebmpapst. Intake sound level: Sound power level according to ISO 13347 / sound pressure level measured at 1 m distance from fan axis. The values given are valid under the specified measuring conditions and may vary due to conditions of installation. For deviations from the standard configuration, the parameters have to be checked on the installed unit.

## Measured values

	U	f	n	P <sub>e</sub>	I	q <sub>v</sub>	p <sub>fs</sub>	q <sub>v</sub>	p <sub>fs</sub>
	V	Hz	min <sup>-1</sup>	W	A	m <sup>3</sup> /h	Pa	cfm	in. wg
1	230	60	1600	355	1.55	6495	0	3825	0.00
2	230	60	1580	364	1.58	6165	20	3630	0.08
3	230	60	1555	377	1.64	5900	35	3470	0.14

U = Voltage · f = Frequency · n = Speed (rpm) · P<sub>e</sub> = Power consumption · I = Current draw · q<sub>v</sub> = Air flow · p<sub>fs</sub> = Pressure increase

