

AC axial fan

sickle-shaped blades (S series)
with guard grille for short nozzle

S4E400-AS02-56 ebmpapst Datasheet
sales@fansco.com
www.fansco.com

Limited partnership · Headquarters Muldingen
Amtsgericht (court of registration) Stuttgart · HRA 590344
General partner Elektrobau Muldingen GmbH · Headquarters Muldingen
Amtsgericht (court of registration) Stuttgart · HRB 590142

Nominal data

Type	S4E400-AS02-56	
Motor	M4E074-GA	
Phase		1~
Nominal voltage	VAC	230
Frequency	Hz	50
Method of obtaining data		ce
Valid for approval/standard		-
Speed (rpm)	min ⁻¹	1370
Power consumption	W	315
Current draw	A	1.4
Capacitor	µF	8
Capacitor voltage	VDB	450
Min. ambient temperature	°C	-25
Max. ambient temperature	°C	40

ml = Max. load · me = Max. efficiency · fa = Free air · cs = Customer specification · ce = Customer equipment
Subject to change



AC axial fan

sickle-shaped blades (S series)
with guard grille for short nozzle

Technical description

Weight	6.79 kg
Size	400 mm
Motor size	74
Rotor surface	Painted black
Terminal box material	ABS plastic
Blade material	Sheet steel, painted black
Guard grille material	Steel, coated with black plastic (RAL 9005)
Number of blades	5
Airflow direction	A
Direction of rotation	Clockwise, viewed toward rotor
Degree of protection	IP44; installation- and position-dependent as per EN 60034-5
Insulation class	"F"
Moisture (F) / Environmental (H) protection class	H1+
Max. permitted ambient temp. for motor (transport/storage)	+80 °C
Min. permitted ambient temp. for motor (transport/storage)	-40 °C
Installation position	Shaft horizontal or rotor on bottom; rotor on top on request
Condensation drainage holes	On rotor side
Mode	S1
Motor bearing	Ball bearing
Touch current according to IEC 60990 (measuring circuit Fig. 4, TN system)	< 0.75 mA
Electrical hookup	Terminal box; Capacitor integrated and connected
Motor protection	Thermal overload protector (TOP) with basic insulation
With cable	Axial
Protection class	I (with customer connection of protective earth)
Motor capacitor according to EN 60252-1 in safety protection class	S0
Conformity with standards	EN 60335-1
Comment on CE	Commissioning not permitted in the European Economic Area
Approval	EAC



AC axial fan

sickle-shaped blades (S series)
with guard grille for short nozzle

Product drawing

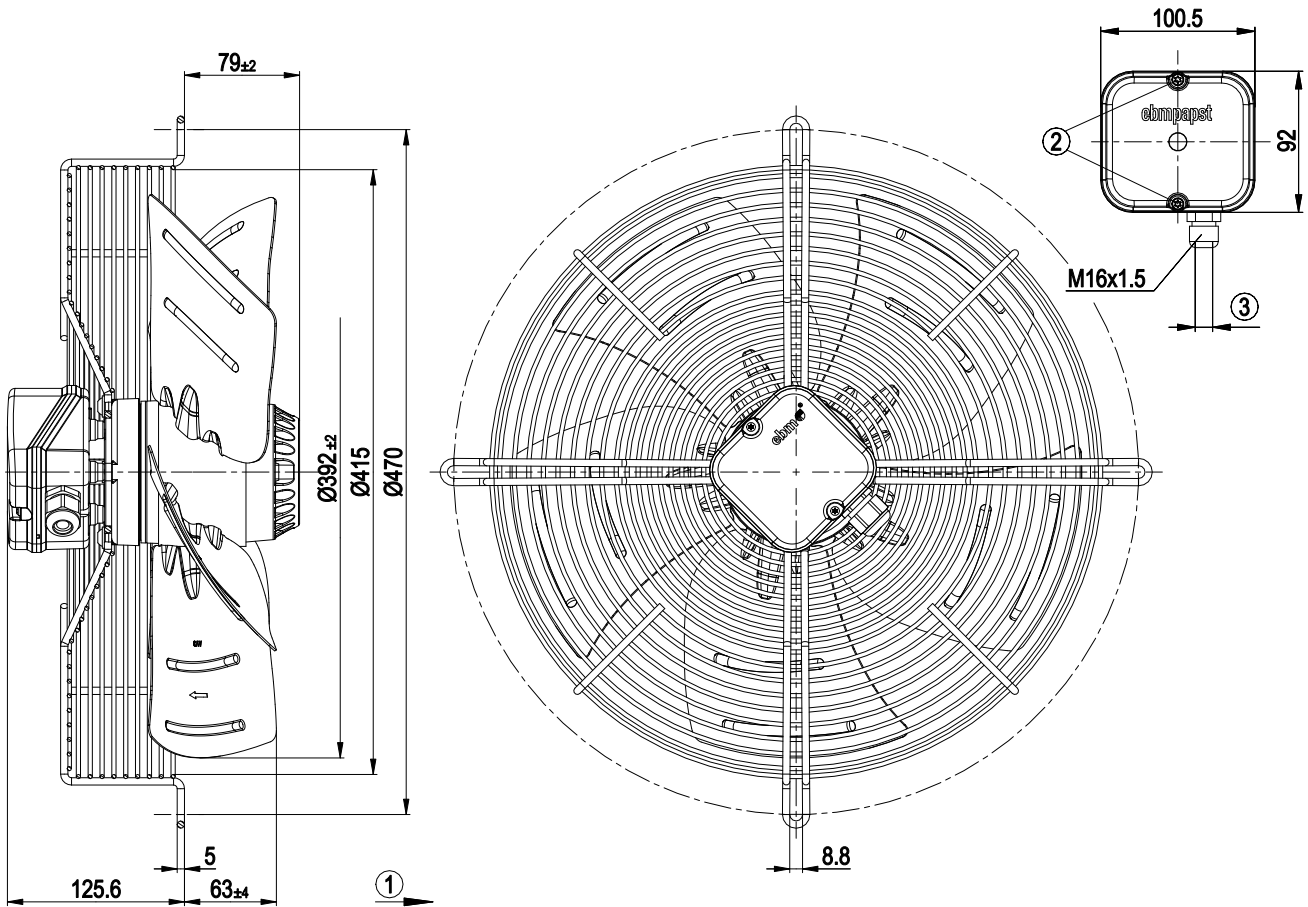

1	Direction of air flow "A"
2	Tightening torque 1.5 ± 0.2 Nm
3	Cable diameter: max. 10 mm, tightening torque 1.3 ± 0.2 Nm



AC axial fan

sickle-shaped blades (S series)
with guard grille for short nozzle

Connection diagram



L	= U1 = blue	Z	brown	N	= U2 = black
PE	green/yellow	TOP	gray		



AC axial fan

sickle-shaped blades (S series)
with guard grille for short nozzle

Curves: Air performance 50 Hz

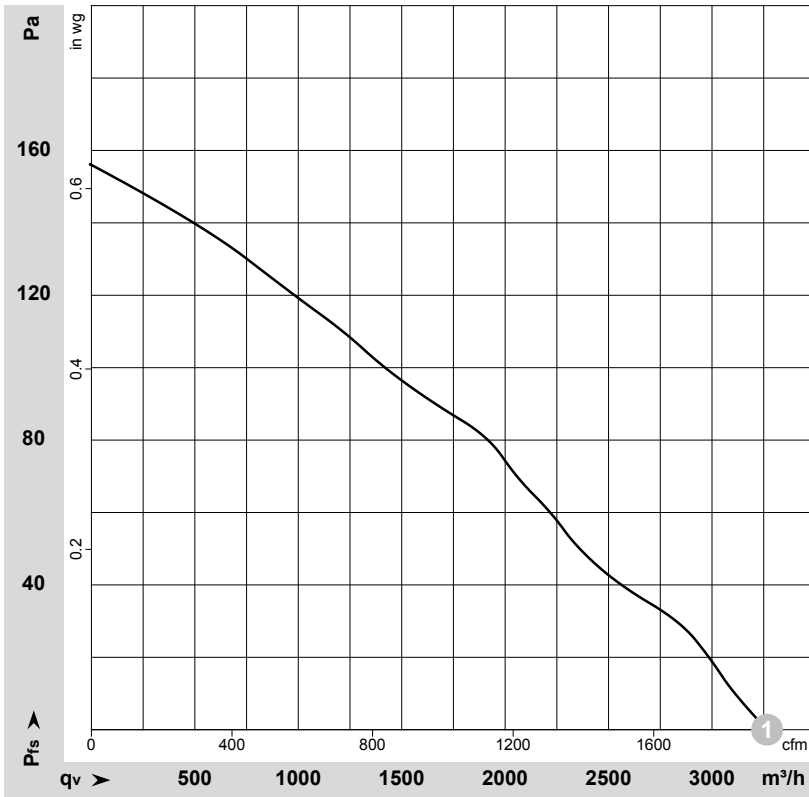

$\rho = 1.15 \text{ kg/m}^3 \pm 2 \%$

Measurement: LU-38204-1

Air performance measured according to ISO 5801 installation category A. For detailed information on the measurement setup, contact ebm-papst. Intake sound level: Sound power level according to ISO 13347 / sound pressure level measured at 1 m distance from fan axis. The values given are valid under the specified measuring conditions and may vary due to conditions of installation. For deviations from the standard configuration, the parameters have to be checked on the installed unit.

Measured values

	U	f	n	P _e	I	q _v	q _v	P _{fs}
	V	Hz	min ⁻¹	W	A	m ³ /h	cfm	in. wg
1	230	50	1370	315	1.40	3265	1920	0.00

U = Voltage · f = Frequency · n = Speed (rpm) · P_e = Power consumption · I = Current draw · q_v = Air flow

