

AC axial fan

blades with special design (K series), single-intake
with guard grille for short nozzle

S4E400-AP02-93 ebmpapst Datasheet
sales@fansco.com
www.fansco.com

Limited partnership · Headquarters Muldingen
Amtsgericht (court of registration) Stuttgart · HRA 590344
General partner Elektrobau Muldingen GmbH · Headquarters Muldingen
Amtsgericht (court of registration) Stuttgart · HRB 590142

Nominal data

Type	S4E400-AP02-93		
Motor	M4E074-EI		
Phase		1~	1~
Nominal voltage	VAC	230	230
Frequency	Hz	50	60
Method of obtaining data		fa	fa
Valid for approval/standard		CE	CE
Speed (rpm)	min ⁻¹	1430	1700
Power consumption	W	160	240
Current draw	A	0.73	1.06
Capacitor	µF	6	6
Capacitor voltage	VDB	400	400
Max. back pressure	Pa	110	75
Max. back pressure	in. wg	0.44	0.3
Min. ambient temperature	°C	-40	-40
Max. ambient temperature	°C	40	40
Starting current	A	2.0	1.9

ml = Max. load · me = Max. efficiency · fa = Free air · cs = Customer specification · ce = Customer equipment
Subject to change

Data according to Commission Regulation (EU) 327/2011 (EN 17166)

		Actual	Req. 2015			
01 Overall efficiency η_{es}	%	32.8	29.4	09 Power consumption P_e	kW	0.21
02 Measurement category		A		09 Air flow q_v	m ³ /h	2695
03 Efficiency category		Static		09 Pressure increase p_{fs}	Pa	96
04 Efficiency grade N		43.4	40	10 Speed (rpm) n	min ⁻¹	1390
05 Variable speed drive		No		11 Specific ratio*		1.00

Data obtained at optimum efficiency level.
The ErP data is determined using a motor-impeller combination in a standardized measurement setup.

* Specific ratio = $1 + p_{fs} / 100\,000\text{ Pa}$

LU-195913



Technical description

Weight	5 kg
Size	400 mm
Motor size	74
Rotor surface	Painted black
Terminal box material	PC/ABS plastic
Blade material	Sheet steel, painted black
Guard grille material	Steel, coated with black plastic (RAL 9005)
Number of blades	5
Airflow direction	V
Direction of rotation	Counterclockwise, viewed toward rotor
Degree of protection	IP44; installation- and position-dependent as per EN 60034-5
Insulation class	"F"
Moisture (F) / Environmental (H) protection class	H1+
Max. permitted ambient temp. for motor (transport/storage)	+ 70 °C
Min. permitted ambient temp. for motor (transport/storage)	- 40 °C
Installation position	Shaft horizontal or rotor on bottom; rotor on top on request
Condensation drainage holes	On rotor side
Mode	S1
Motor bearing	Ball bearing with low-temperature lubricant
Touch current according to IEC 60990 (measuring circuit Fig. 4, TN system)	< 0.75 mA
Electrical hookup	Terminal box; Capacitor integrated and connected
Motor protection	Thermal overload protector (TOP) internally connected
With cable	Variable
Protection class	I (with customer connection of protective earth)
Motor capacitor according to EN 60252-1 in safety protection class	S0
Conformity with standards	EN 60335-1; CE

AC axial fan

blades with special design (K series), single-intake
with guard grille for short nozzle

Product drawing

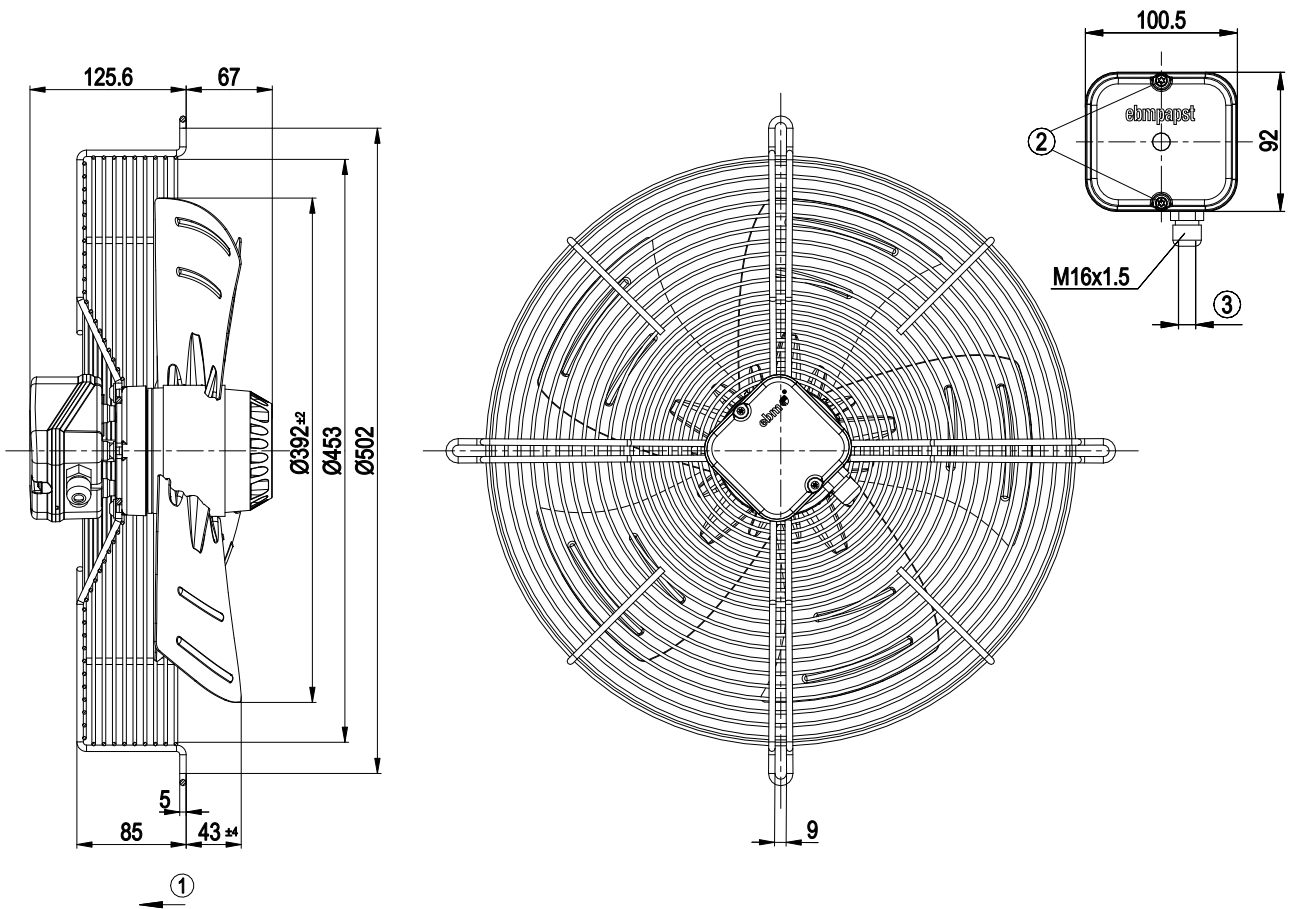

1	Airflow direction "V"
2	Tightening torque 1.5 ± 0.2 Nm
3	Cable diameter max. 7.5 mm, tightening torque 1.3 ± 0.2 Nm

Connection diagram



L	= U1 = blue	Z	brown	N	= U2 = black
PE	green/yellow				



AC axial fan

blades with special design (K series), single-intake
with guard grille for short nozzle

Curves: Air performance 50 Hz

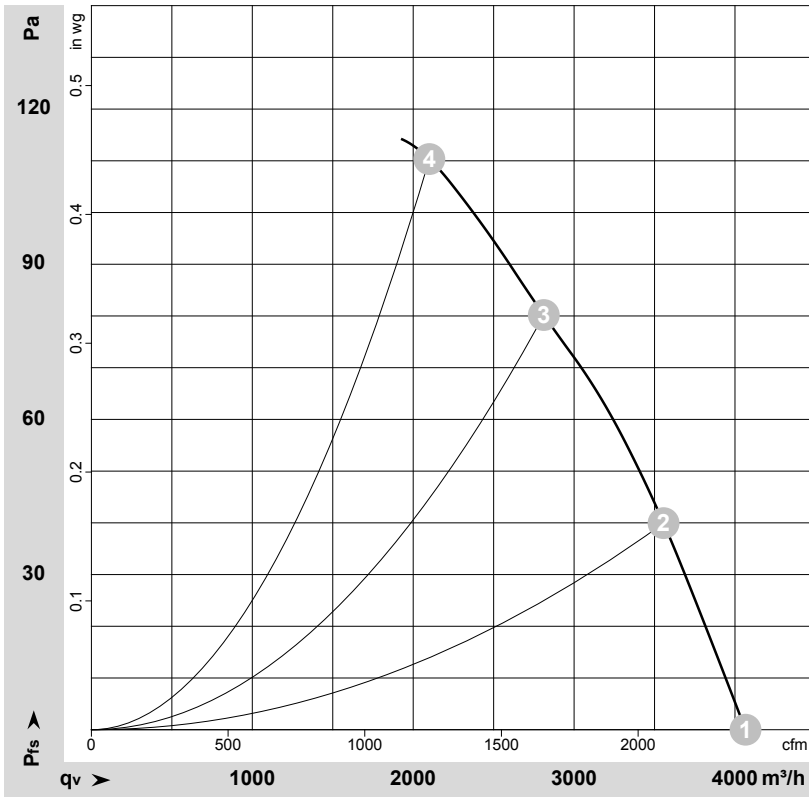

$\rho = 1.15 \text{ kg/m}^3 \pm 2 \%$

Measurement: LU-146030-1

Air performance measured according to ISO 5801 installation category A. For detailed information on the measurement setup, contact ebmpapst. Intake sound level: Sound power level according to ISO 13347 / sound pressure level measured at 1 m distance from fan axis. The values given are valid under the specified measuring conditions and may vary due to conditions of installation. For deviations from the standard configuration, the parameters have to be checked on the installed unit.

Measured values

	U	f	n	P _e	I	LpA _{in}	LwA _{in}	LwA _{out}	q _v	P _{fs}	q _v	P _{fs}
	V	Hz	min ⁻¹	W	A	dB(A)	dB(A)	dB(A)	m ³ /h	Pa	cfm	in. wg
1	230	50	1430	160	0.73	68	74	74	4065	0	2395	0.00
2	230	50	1410	189	0.84	66	72	72	3555	40	2095	0.16
3	230	50	1390	207	0.92	65	72	72	2810	80	1655	0.32
4	230	50	1370	225	0.99	64	71	71	2100	110	1235	0.44

U = Voltage · f = Frequency · n = Speed (rpm) · P_e = Power consumption · I = Current draw · LpA_{in} = Sound pressure level intake side · LwA_{in} = Sound power level intake side
LwA_{out} = Sound power level outlet side · q_v = Air flow · P_{fs} = Pressure increase



AC axial fan

blades with special design (K series), single-intake
with guard grille for short nozzle

Curves: Air performance 60 Hz

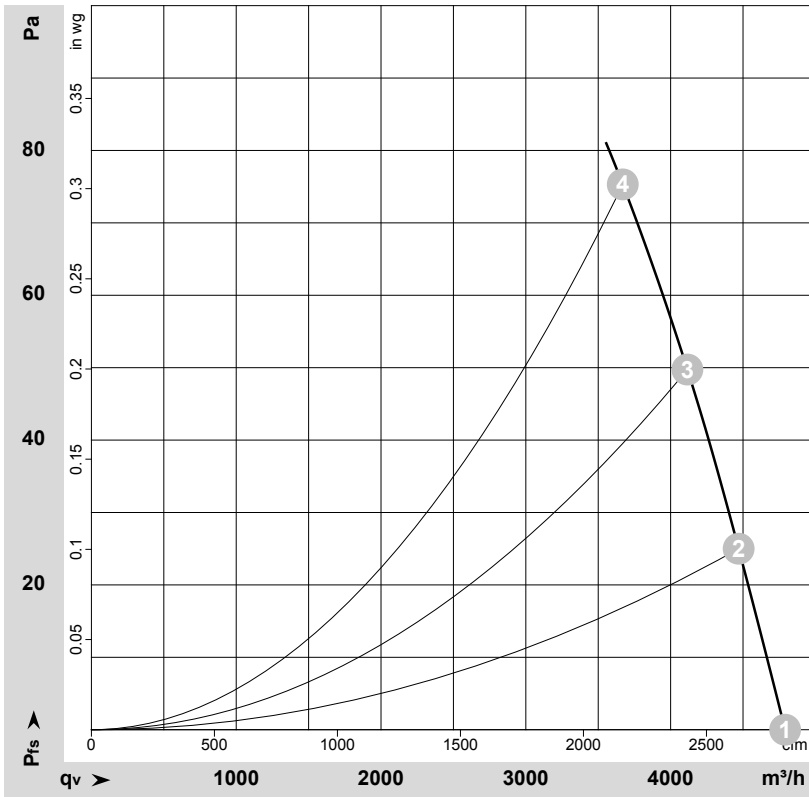

$\rho = 1.15 \text{ kg/m}^3 \pm 2 \%$

Measurement: LU-146034-1

Air performance measured according to ISO 5801 installation category A. For detailed information on the measurement setup, contact ebmpapst. Intake sound level: Sound power level according to ISO 13347 / sound pressure level measured at 1 m distance from fan axis. The values given are valid under the specified measuring conditions and may vary due to conditions of installation. For deviations from the standard configuration, the parameters have to be checked on the installed unit.

Measured values

	U	f	n	P _e	I	LpA _{in}	LwA _{in}	LwA _{out}	q _v	P _{fs}	q _v	P _{fs}
	V	Hz	min ⁻¹	W	A	dB(A)	dB(A)	dB(A)	m ³ /h	Pa	cfm	in. wg
1	230	60	1700	240	1.06	71	78	77	4790	0	2820	0.00
2	230	60	1645	262	1.16	71	77	77	4470	25	2630	0.10
3	230	60	1620	275	1.21	69	75	75	4115	50	2425	0.20
4	230	60	1580	295	1.29	67	74	74	3670	75	2160	0.30

U = Voltage · f = Frequency · n = Speed (rpm) · P_e = Power consumption · I = Current draw · LpA_{in} = Sound pressure level intake side · LwA_{in} = Sound power level intake side
LwA_{out} = Sound power level outlet side · q_v = Air flow · p_{fs} = Pressure increase

