

S4E360-EC20-05

AC axial fan

blades with special design (K series), single-intake
with guard grille for full nozzle



S4E360-EC20-05 ebmpapst Datasheet
sales@fansco.com
www.fansco.com

Limited partnership · Headquarters Muldingen
Amtsgericht (court of registration) Stuttgart · HRA 590344

General partner Elektrobau Muldingen GmbH · Headquarters Muldingen
Amtsgericht (court of registration) Stuttgart · HRB 590142

Nominal data

Type	S4E360-EC20-05		
Motor	M4E068-DF		
Phase		1~	1~
Nominal voltage	VAC	230	230
Frequency	Hz	50	60
Method of obtaining data		fa	fa
Valid for approval/standard		CE	CE
Speed (rpm)	min ⁻¹	1320	1430
Power consumption	W	115	145
Current draw	A	0.54	0.64
Capacitor	µF	3	3
Capacitor voltage	VDB	400	400
Capacitor standard		S0 (CE)	S0 (CE)
Max. back pressure	Pa	55	40
Max. back pressure	in. wg	0.22	0.16
Min. ambient temperature	°C	-25	-25
Max. ambient temperature	°C	40	40
Starting current	A	1.1	1.06

ml = Max. load · me = Max. efficiency · fa = Free air · cs = Customer specification · ce = Customer equipment
Subject to change



AC axial fan

blades with special design (K series), single-intake
with guard grille for full nozzle

Technical description

Weight	2.1 kg
Size	360 mm
Motor size	68
Rotor surface	Painted black
Blade material	PP plastic
Guard grille material	Steel, phosphated and coated with black plastic (RAL 9005)
Number of blades	4
Airflow direction	V
Direction of rotation	Counterclockwise, viewed toward rotor
Degree of protection	IP44; installation- and position-dependent as per EN 60034-5
Insulation class	"B"
Moisture (F) / Environmental (H) protection class	H1
Max. permitted ambient temp. for motor (transport/storage)	+80 °C
Min. permitted ambient temp. for motor (transport/storage)	-40 °C
Installation position	Shaft horizontal or rotor on top; rotor on bottom on request
Mode	S1
Motor bearing	Ball bearing
Touch current according to IEC 60990 (measuring circuit Fig. 4, TN system)	< 0.75 mA
Motor protection	Thermal overload protector (TOP) internally connected
With cable	Axial
Protection class	I (with customer connection of protective earth)
Conformity with standards	EN 60335-1; CE
Approval	EAC



AC axial fan

blades with special design (K series), single-intake
with guard grille for full nozzle

Product drawing

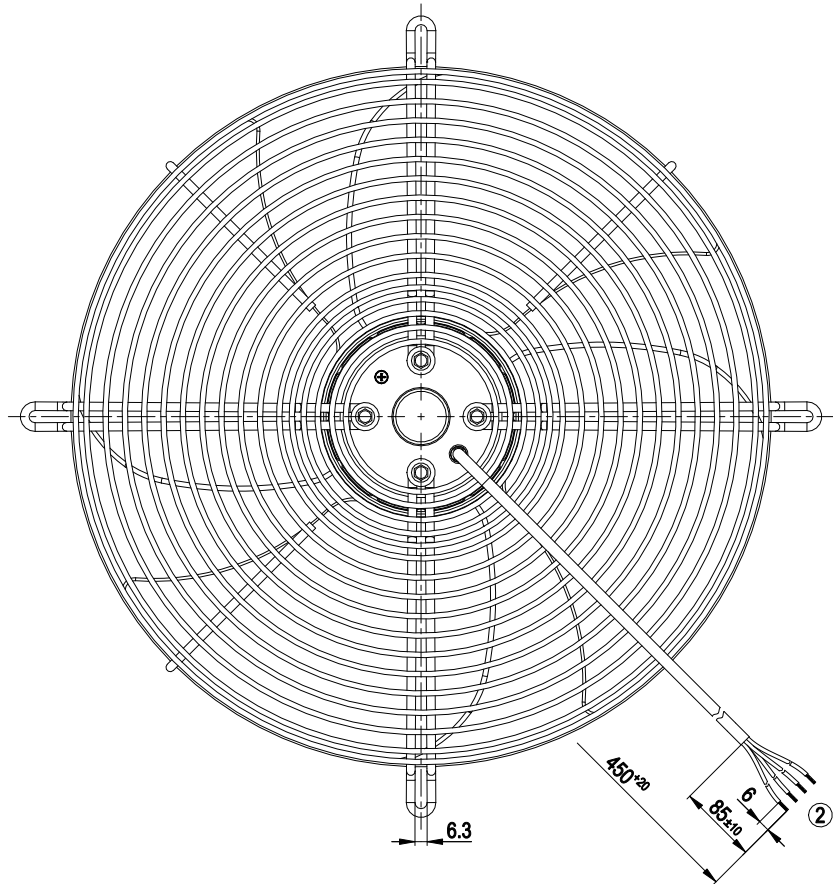
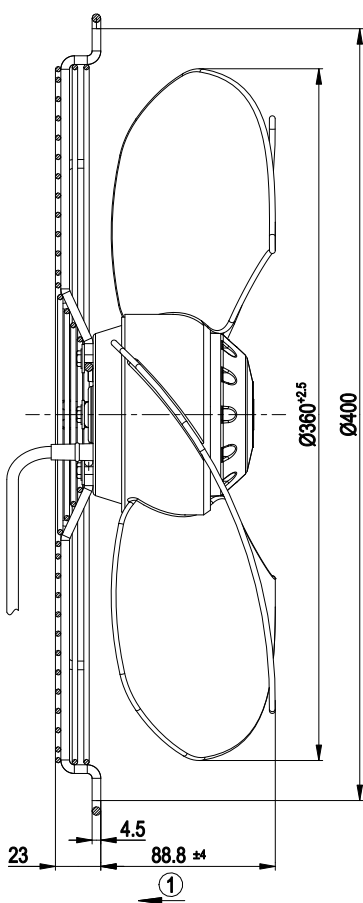

1	Airflow direction "V"
2	Cable PVC 4G 0.5 mm ²
	4x splice

Connection diagram

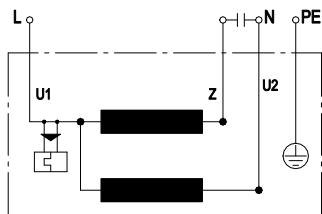

U1	blue	Z	brown	U2	black
PE	green/yellow				



AC axial fan

blades with special design (K series), single-intake
with guard grille for full nozzle

Curves: Air performance 50 Hz

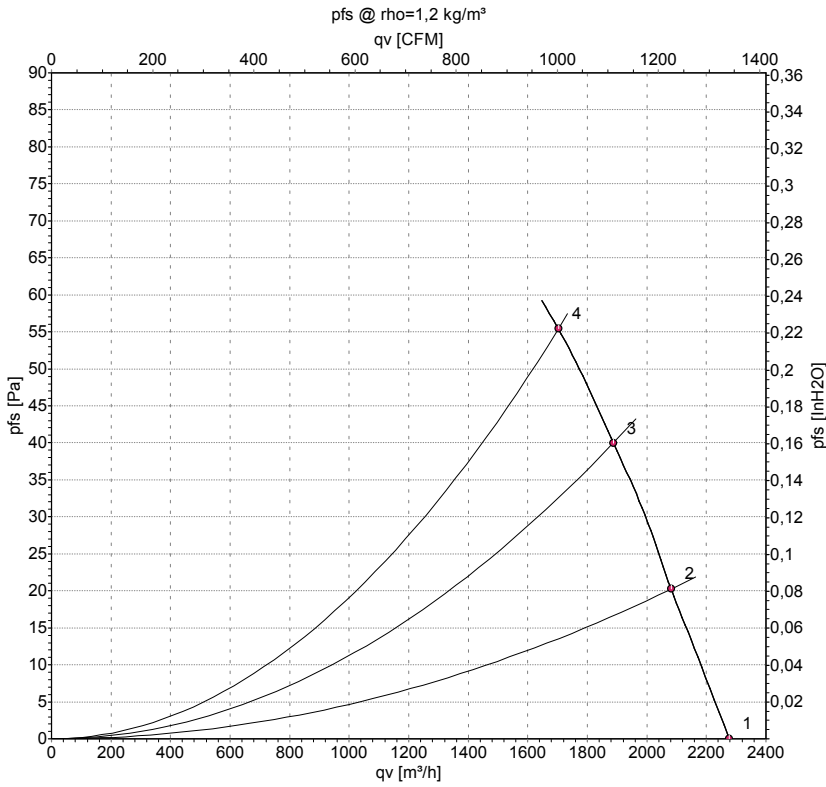

Measurement: LU-41798-1

Air performance measured according to ISO 5801 installation category A. For detailed information on the measurement setup, contact ebm-papst. Intake sound level: Sound power level according to ISO 13347 / sound pressure level measured at 1 m distance from fan axis. The values given are valid under the specified measuring conditions and may vary due to conditions of installation. For deviations from the standard configuration, the parameters have to be checked on the installed unit.

Measured values

	U	f	n	P _e	I	q _v	p _{fs}	q _v	p _{fs}
	V	Hz	min ⁻¹	W	A	m³/h	Pa	cfm	in. wg
1	230	50	1320	115	0.54	2275	0	1340	0.00
2	230	50	1310	116	0.56	2080	20	1225	0.08
3	230	50	1300	119	0.57	1885	40	1110	0.16
4	230	50	1295	121	0.58	1705	55	1000	0.22

U = Voltage · f = Frequency · n = Speed (rpm) · P_e = Power consumption · I = Current draw · q_v = Air flow · p_{fs} = Pressure increase



AC axial fan

blades with special design (K series), single-intake
with guard grille for full nozzle

Curves: Air performance 60 Hz

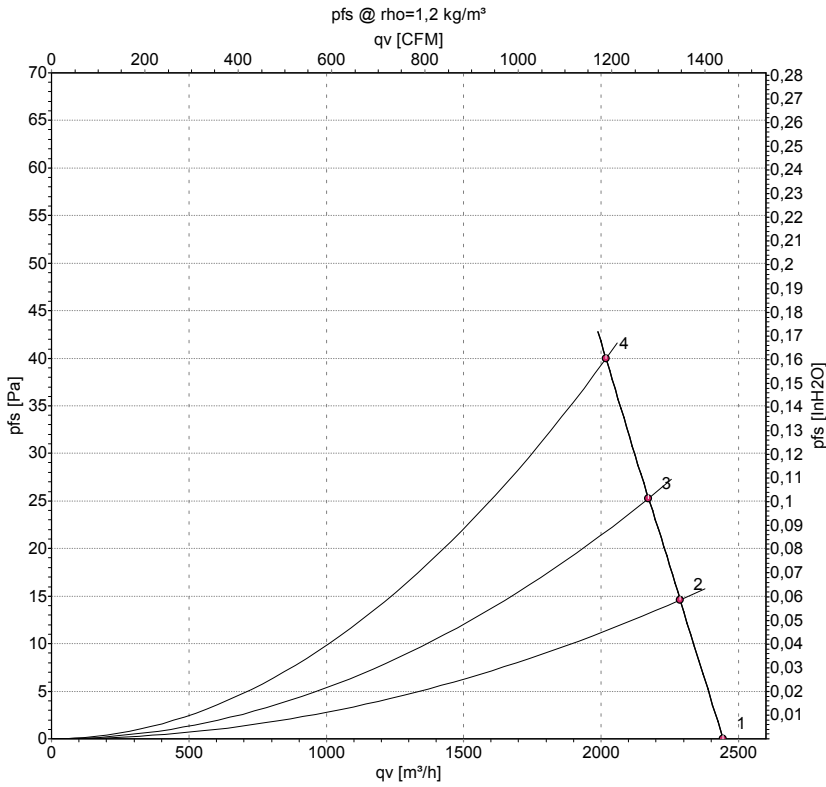

Measurement: LU-41799-1

Air performance measured according to ISO 5801 installation category A. For detailed information on the measurement setup, contact ebm-papst. Intake sound level: Sound power level according to ISO 13347 / sound pressure level measured at 1 m distance from fan axis. The values given are valid under the specified measuring conditions and may vary due to conditions of installation. For deviations from the standard configuration, the parameters have to be checked on the installed unit.

Measured values

	U	f	n	P _e	I	q _v	p _{fs}	q _v	p _{fs}
	V	Hz	min ⁻¹	W	A	m ³ /h	Pa	cfm	in. wg
1	230	60	1430	145	0.64	2445	0	1440	0.00
2	230	60	1415	146	0.64	2290	15	1345	0.06
3	230	60	1400	149	0.66	2175	25	1280	0.10
4	230	60	1380	152	0.67	2020	40	1190	0.16

U = Voltage · f = Frequency · n = Speed (rpm) · P_e = Power consumption · I = Current draw · q_v = Air flow · p_{fs} = Pressure increase

