

# AC axial fan - HyBlade

sickle-shaped blades (S series)

with guard grille for full nozzle

S4E350-BN02-39 ebmpapst Datasheet

sales@fansco.com

www.fansco.com

Limited partnership · Headquarters Muldingen

Amtsgericht (court of registration) Stuttgart · HRA 590344

General partner Elektrobau Muldingen GmbH · Headquarters Muldingen

Amtsgericht (court of registration) Stuttgart · HRB 590142

## Nominal data

<b>Type</b>	<b>S4E350-BN02-39</b>	
<b>Motor</b>	<b>M4E074-DF</b>	
Phase		1~
Nominal voltage	VAC	230
Frequency	Hz	50
Method of obtaining data		ml
Valid for approval/standard		CE
Speed (rpm)	min <sup>-1</sup>	1340
Power consumption	W	165
Current draw	A	0.73
Capacitor	μF	4
Capacitor voltage	VDB	400
Capacitor standard		S0 (CE)
Max. back pressure	Pa	90
Max. back pressure	inH <sub>2</sub> O	0.36
Min. ambient temperature	°C	-25
Max. ambient temperature	°C	65
Starting current	A	1.4

ml = Max. load · me = Max. efficiency · fa = Free air · cs = Customer specification · ce = Customer equipment  
Subject to change

## Data according to ErP Directive

		Actual	Req. 2015			
01 Overall efficiency $\eta_{es}$	%	29	28.6	09 Power consumption $P_e$	kW	0.16
02 Measurement category		A		09 Air flow $q_v$	m <sup>3</sup> /h	2160
03 Efficiency category		Static		09 Pressure increase $p_{fs}$	Pa	75
04 Efficiency grade N		40.4	40	10 Speed (rpm) n	min <sup>-1</sup>	1355
05 Variable speed drive		No		11 Specific ratio*		1.00

Data obtained at optimum efficiency level.

The ErP data is determined using a motor-impeller combination in a standardized measurement setup.

\* Specific ratio =  $1 + p_g / 100\,000\text{ Pa}$

LU-131320



# AC axial fan - HyBlade

sickle-shaped blades (S series)

with guard grille for full nozzle

## Technical description

Weight	4.51 kg
Fan size	350 mm
Rotor surface	Painted black
Terminal box material	ABS plastic
Blade material	PP plastic
Guard grille material	Steel, coated with black plastic (RAL 9005)
Number of blades	5
Airflow direction	"A"
Direction of rotation	Clockwise, viewed toward rotor
Degree of protection	IP44; installation- and position-dependent as per EN 60034-5
Insulation class	"F"
Moisture (F) / Environmental (H) protection class	H0+
Max. permitted ambient temp. for motor (transport/storage)	+ 80 °C
Min. permitted ambient temp. for motor (transport/storage)	- 40 °C
Installation position	Shaft horizontal or rotor on bottom; rotor on top on request
Condensation drainage holes	On rotor side
Mode	S1
Motor bearing	Ball bearing
Touch current according to IEC 60990 (measuring circuit Fig. 4, TN system)	< 0.75 mA
Electrical hookup	Via terminal box, capacitor integrated and connected
Motor protection	Thermal overload protector (TOP) internally connected
With cable	Variable
Protection class	I (with customer connection of protective earth)
Motor capacitor according to EN 60252-1 in safety protection class	S0
Conformity with standards	EN 60335-1; CE



# AC axial fan - HyBlade

sickle-shaped blades (S series)  
with guard grille for full nozzle

## Product drawing

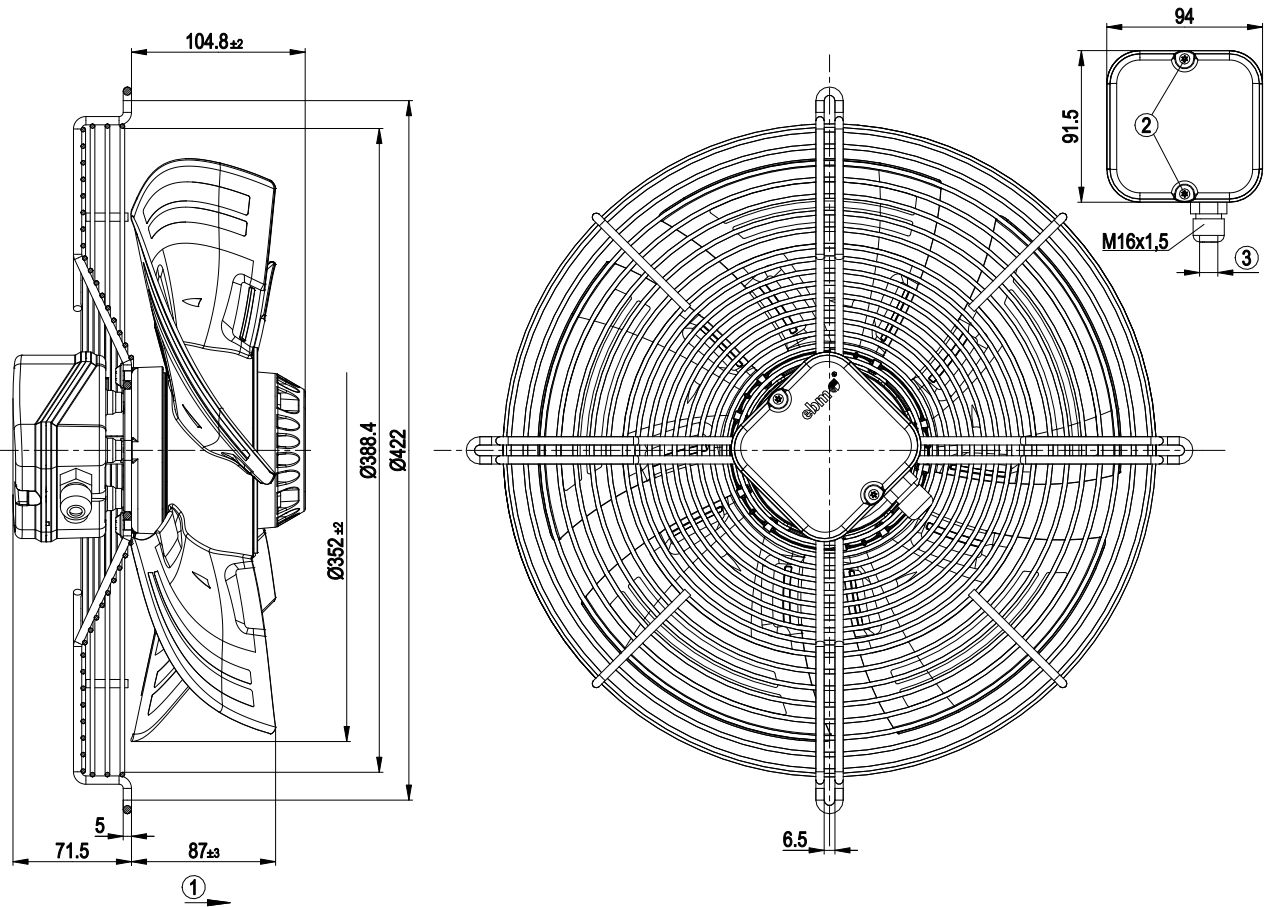

1	Direction of air flow "A"
2	Tightening torque $0.5 \pm 0.1$ Nm
3	Cable diameter max. 7.5 mm, tightening torque $1.3 \pm 0.2$ Nm

## Connection diagram



L	= U1 = blue	Z	brown	N	= U2 = black
PE	green/yellow				



# AC axial fan - HyBlade

sickle-shaped blades (S series)

with guard grille for full nozzle

## Curves: Air performance 50 Hz

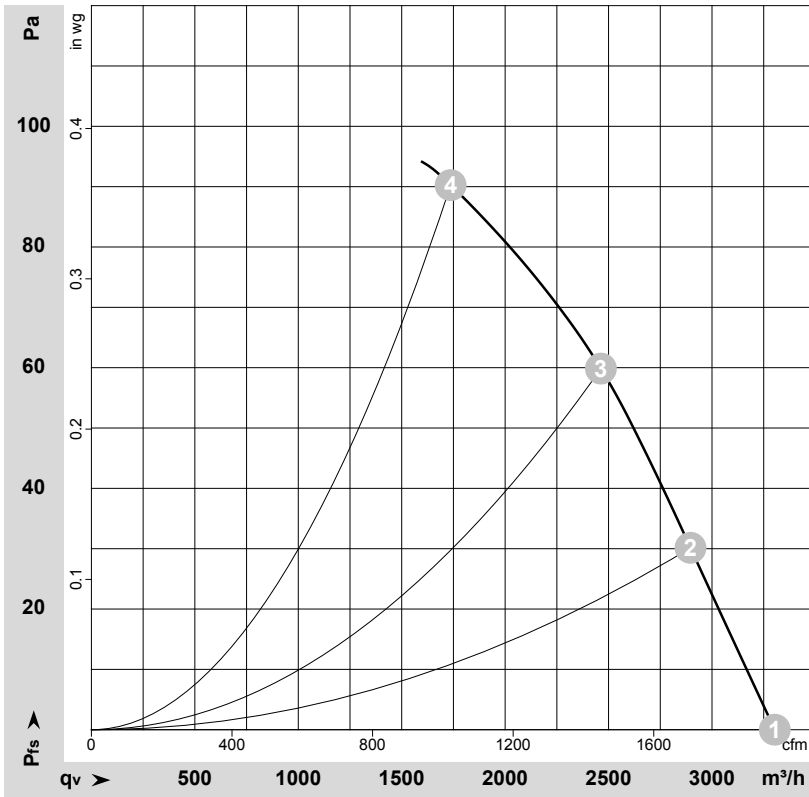

$\rho = 1.179 \text{ kg/m}^3 \pm 2 \%$

Measurement: LU-131320-1

Air performance measured according to ISO 5801 installation category A. For detailed information on the measurement setup, contact ebmpapst. Intake sound level: Sound power level according to ISO 13347 / sound pressure level measured at 1 m distance from fan axis. The values given are valid under the specified measuring conditions and may vary due to conditions of installation. For deviations from the standard configuration, the parameters have to be checked on the installed unit.

## Measured values

	U	f	n	P <sub>e</sub>	I	LpA <sub>in</sub>	LwA <sub>in</sub>	q <sub>v</sub>	p <sub>fs</sub>	q <sub>v</sub>	p <sub>fs</sub>
	V	Hz	min <sup>-1</sup>	W	A	dB(A)	dB(A)	m <sup>3</sup> /h	Pa	cfm	inH <sub>2</sub> O
1	230	50	1400	135	0.60	62	69	3305	0	1945	0.00
2	230	50	1380	145	0.64	59	67	2895	30	1705	0.12
3	230	50	1365	155	0.68	56	64	2465	60	1450	0.24
4	230	50	1340	165	0.73	58	66	1735	90	1020	0.36

U = Power supply · f = Frequency · n = Speed (rpm) · P<sub>e</sub> = Power consumption · I = Current draw · LpA<sub>in</sub> = Sound pressure level intake side · LwA<sub>in</sub> = Sound power level intake side  
 q<sub>v</sub> = Air flow · p<sub>fs</sub> = Pressure increase

