

S4E350-AP06-30/A04 ebmpapst Datasheet  
 sales@fansco.com  
 www.fansco.com



## Nominal data

<b>Type</b>	S4E350-AP06-30/A04		
<b>Motor</b>	M4E074-DF		
Phase		1~	1~
Nominal voltage	VAC	230	230
Frequency	Hz	50	60
Type of data definition		fa	fa
Valid for approval / standard		-	-
Speed	min <sup>-1</sup>	1400	1590
Power input	W	130	190
Current draw	A	0.58	0.83
Motor capacitor	µF	4	4
Capacitor voltage	VDB	400	400
Max. back pressure	Pa	90	60
Min. ambient temperature	°C	-25	-25
Max. ambient temperature	°C	55	55
Starting current	A	1.2	1.1

ml = max. load · me = max. efficiency · fa = running at free air · cs = customer specs · cu = customer unit  
 Subject to alterations

## Data according to ErP directive

Installation category	A
Efficiency category	Static
Variable speed drive	No
Specific ratio*	1.00

\* Specific ratio =  $1 + p_g / 100\,000\text{ Pa}$

	Actual	Request 2013	Request 2015
Overall efficiency $\eta_{es}$	28.5	24.5	28.5
Efficiency grade N	40	36	40
Power input $P_e$	kW	0.15	
Air flow $q_v$	m <sup>3</sup> /h	2200	
Pressure increase $p_{fs}$	Pa	70	
Speed n	min <sup>-1</sup>	1345	

Data established at point of optimum efficiency



# AC axial fan

sickled blades (S series)

## Technical features

<b>Mass</b>	5.2 kg
<b>Size</b>	350 mm
<b>Surface of rotor</b>	Coated in black
<b>Material of blades</b>	Sheet steel, coated in black
<b>Number of blades</b>	5
<b>Direction of air flow</b>	"V"
<b>Direction of rotation</b>	Counter-clockwise, seen on rotor
<b>Type of protection</b>	IP 44; Depending on installation and position as per EN 60034-5
<b>Insulation class</b>	"F"
<b>Humidity class</b>	F1-2
<b>Max. permissible ambient motor temp. (transp./ storage)</b>	+ 80 °C
<b>Min. permissible ambient motor temp. (transp./storage)</b>	- 40 °C
<b>Mounting position</b>	Shaft horizontal or rotor on bottom; rotor on top on request
<b>Condensate discharge holes</b>	Rotor-side
<b>Operation mode</b>	S1
<b>Motor bearing</b>	Ball bearing
<b>Touch current acc. IEC 60990 (measuring network Fig. 4, TN system)</b>	< 0.75 mA
<b>Motor protection</b>	Thermal overload protector (TOP) wired internally
<b>Cable exit</b>	Variable
<b>Protection class</b>	I (if protective earth is connected by customer)
<b>Product conforming to standard</b>	EN 60335-1
<b>Approval</b>	CCC



## Product drawing

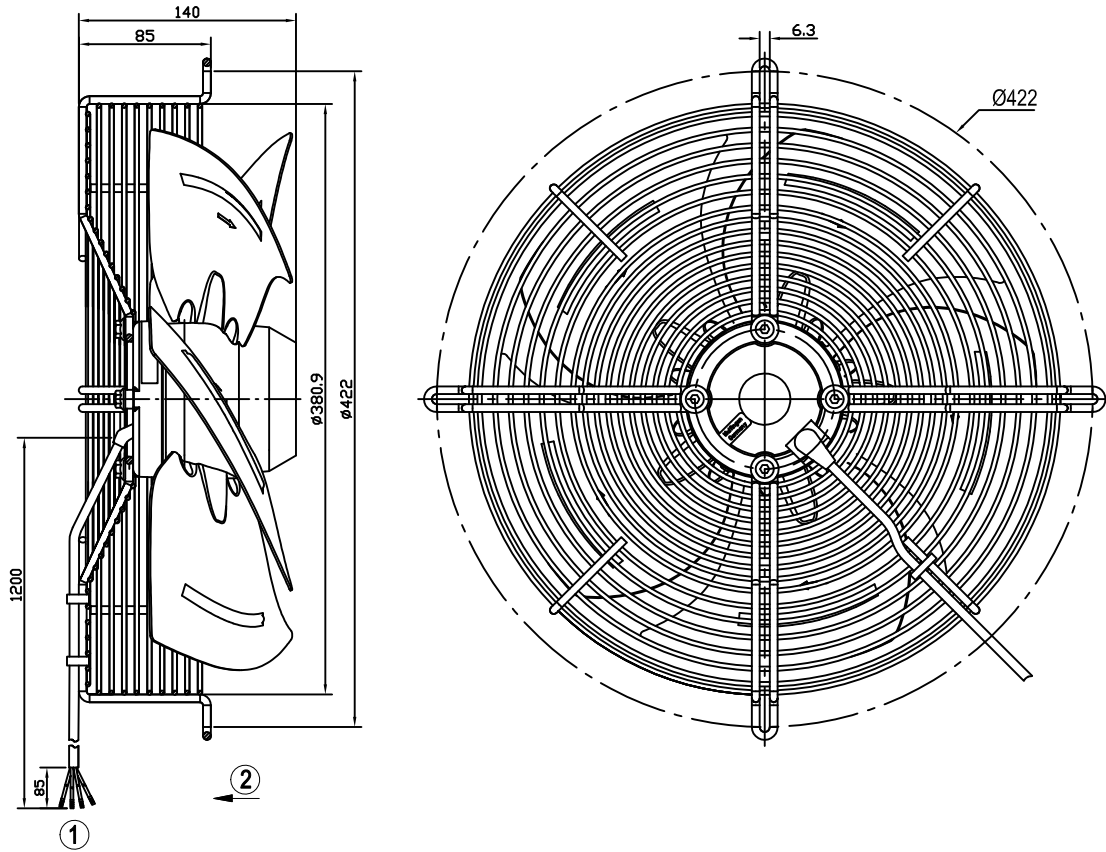

- 1 Connection line silicone 4 x 0.5 mm<sup>2</sup>, 4 x brass lead tips crimped
- 2 Direction of air flow "V"

## Connection screen

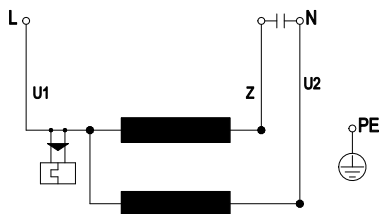

U1	blue	Z	brown	U2	black
PE	green/yellow				



## Charts: Air flow 50 Hz

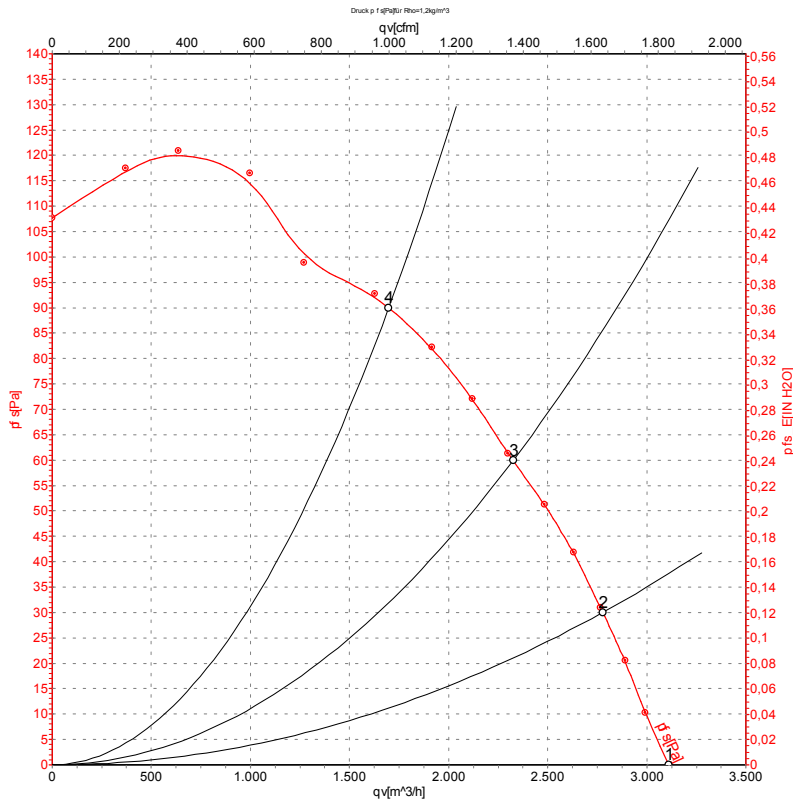

Measurement: LU-28525

Air performance measured as per ISO 5801 Installation category A. For detailed information on the measuring set-up, please contact ebm-papst. Suction-side noise levels: L<sub>wA</sub> measured as per ISO 13347 / L<sub>pA</sub> measured with 1m distance to fan axis. The values given are valid under the measuring conditions mentioned above and may vary according to the actual installation situation. With any deviation from the standard set-up, the specific values have to be checked and reviewed with the unit installed.

## Measured values

	U	f	n	P <sub>e</sub>	I	qv	P <sub>fs</sub>
	V	Hz	min <sup>-1</sup>	W	A	m <sup>3</sup> /h	Pa
1	230	50	1400	130	0.58	3110	0
2	230	50	1380	140	0.61	2780	30
3	230	50	1355	151	0.66	2325	60
4	230	50	1290	174	0.76	1700	90

U = Supply voltage · f = Frequency · n = Speed · P<sub>e</sub> = Power input · I = Current draw · qv = Air flow · P<sub>fs</sub> = Pressure increase



## Charts: Air flow 60 Hz

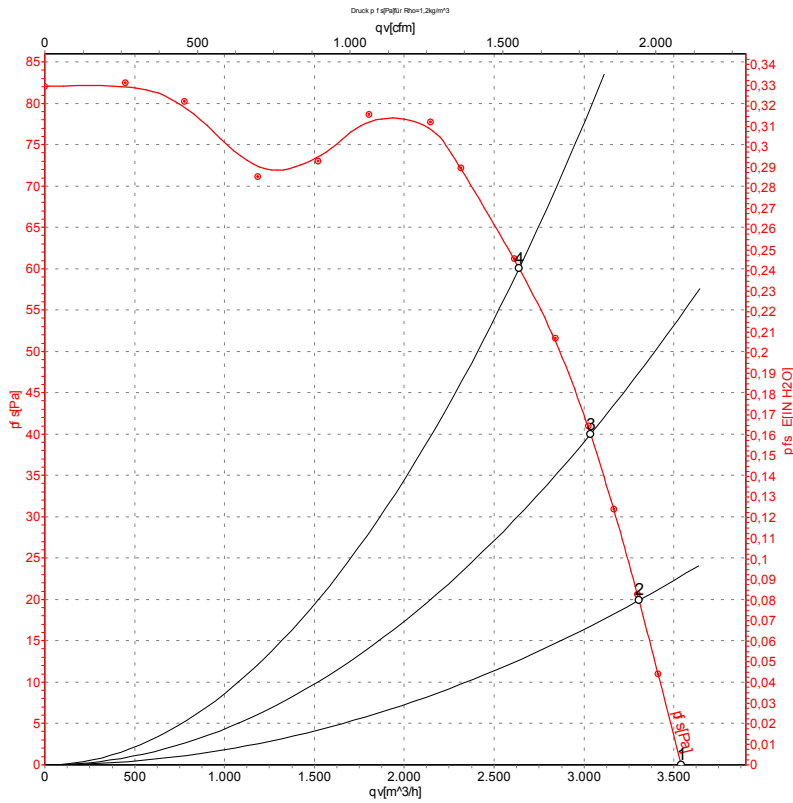

Measurement: LU-28527

Air performance measured as per ISO 5801 Installation category A. For detailed information on the measuring set-up, please contact ebm-papst. Suction-side noise levels: L<sub>wA</sub> measured as per ISO 13347 / L<sub>pA</sub> measured with 1m distance to fan axis. The values given are valid under the measuring conditions mentioned above and may vary according to the actual installation situation. With any deviation from the standard set-up, the specific values have to be checked and reviewed with the unit installed.

## Measured values

	U	f	n	P <sub>e</sub>	I	qv	P <sub>fs</sub>
	V	Hz	min <sup>-1</sup>	W	A	m <sup>3</sup> /h	Pa
1	230	60	1590	190	0.83	3540	0
2	230	60	1565	196	0.85	3305	20
3	230	60	1520	203	0.88	3035	40
4	230	60	1455	208	0.90	2640	60

U = Supply voltage · f = Frequency · n = Speed · P<sub>e</sub> = Power input · I = Current draw · qv = Air flow · P<sub>fs</sub> = Pressure increase

