

S4E350-AO02-98 ebmpapst Datasheet
 sales@fansco.com
 www.fansco.com

Limited partnership · Headquarters Mulfingen
 Amtsgericht (court of registration) Stuttgart · HRA 590344
 General partner Elektrobau Mulfingen GmbH · Headquarters Mulfingen
 Amtsgericht (court of registration) Stuttgart · HRB 590142

Nominal data

Type	S4E350-AO02-98		
Motor	M4E074-EI		
Phase		1~	1~
Nominal voltage	VAC	230	230
Frequency	Hz	50	60
Method of obtaining data		ml	ml
Valid for approval/standard		CE	CE
Speed (rpm)	min ⁻¹	1400	1600
Power consumption	W	180	250
Current draw	A	0.81	1.1
Capacitor	µF	5	5
Capacitor voltage	VDB	400	400
Capacitor standard		S0 (CE)	S0 (CE)
Max. back pressure	Pa	100	100
Max. back pressure	inH ₂ O	0.4	0.4
Min. ambient temperature	°C	-40	-40
Max. ambient temperature	°C	55	30
Starting current	A	2.2	1.92

ml = Max. load · me = Max. efficiency · fa = Free air · cs = Customer specification · ce = Customer equipment
 Subject to change

Data according to ErP Directive

		Actual	Req. 2015			
01 Overall efficiency η_{es}	%	29.3	28.6	09 Power consumption P_e	kW	0.16
02 Measurement category		A		09 Air flow q_v	m ³ /h	2260
03 Efficiency category		Static		09 Pressure increase p_{fs}	Pa	80
04 Efficiency grade N		40.7	40	10 Speed (rpm) n	min ⁻¹	1410
05 Variable speed drive		No		11 Specific ratio*		1.00

Data obtained at optimum efficiency level.

The ErP data is determined using a motor-impeller combination in a standardized measurement setup.

* Specific ratio = $1 + p_g / 100\,000\text{ Pa}$

LU-130206



AC axial fan

sickle-shaped blades (S series), single-intake
with guard grille for short nozzle

Technical description

Weight	5.8 kg
Fan size	350 mm
Rotor surface	Painted black
Terminal box material	ABS plastic
Blade material	Press-fitted sheet steel blank, sprayed with PP plastic
Guard grille material	Steel, coated with black plastic (RAL 9005)
Number of blades	5
Airflow direction	"V"
Direction of rotation	Counterclockwise, viewed toward rotor
Degree of protection	IP44; installation- and position-dependent as per EN 60034-5
Insulation class	"F"
Moisture (F) / Environmental (H) protection class	F2-2
Max. permitted ambient temp. for motor (transport/storage)	+ 70 °C
Min. permitted ambient temp. for motor (transport/storage)	- 40 °C
Installation position	Shaft horizontal or rotor on bottom; rotor on top on request
Condensation drainage holes	On rotor side
Mode	S1
Motor bearing	Ball bearing with low-temperature lubricant
Touch current according to IEC 60990 (measuring circuit Fig. 4, TN system)	< 0.75 mA
Electrical hookup	Via terminal box, capacitor integrated and connected
Motor protection	Thermal overload protector (TOP) internally connected
With cable	Variable
Protection class	I (with customer connection of protective earth)
Motor capacitor according to EN 60252-1 in safety protection class	S0
Conformity with standards	EN 60335-1; CE



AC axial fan

sickle-shaped blades (S series), single-intake
with guard grille for short nozzle

Product drawing

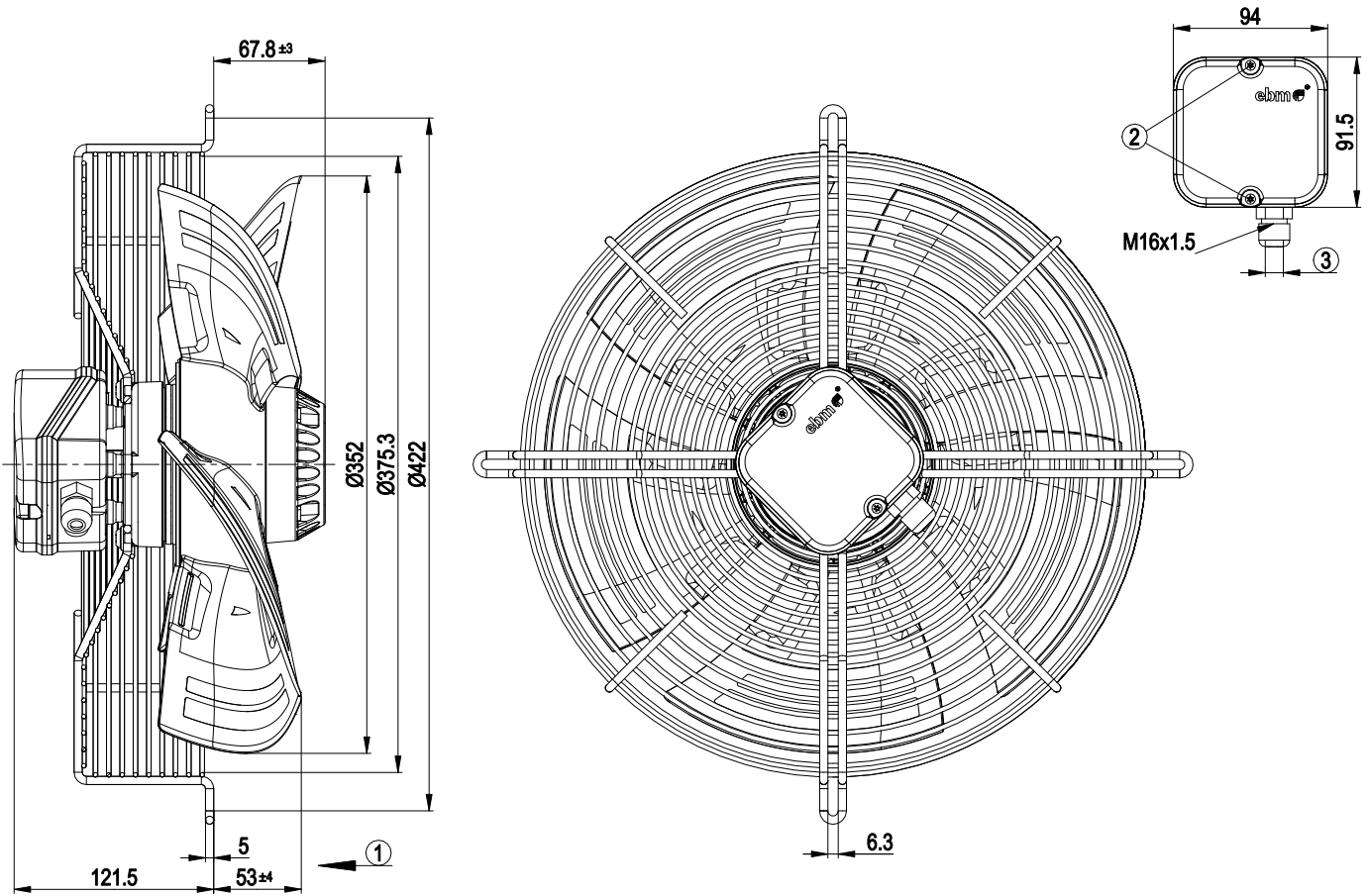

1	Direction of air flow "V"
2	Tightening torque 0.5 ± 0.1 Nm
3	Cable diameter max. 7.5 mm, tightening torque 1.3 ± 0.2 Nm

Connection diagram



L	= U1 = blue	Z	brown	N	= U2 = black
PE	green/yellow				



AC axial fan

sickle-shaped blades (S series), single-intake
with guard grille for short nozzle

Curves: Air performance 50 Hz

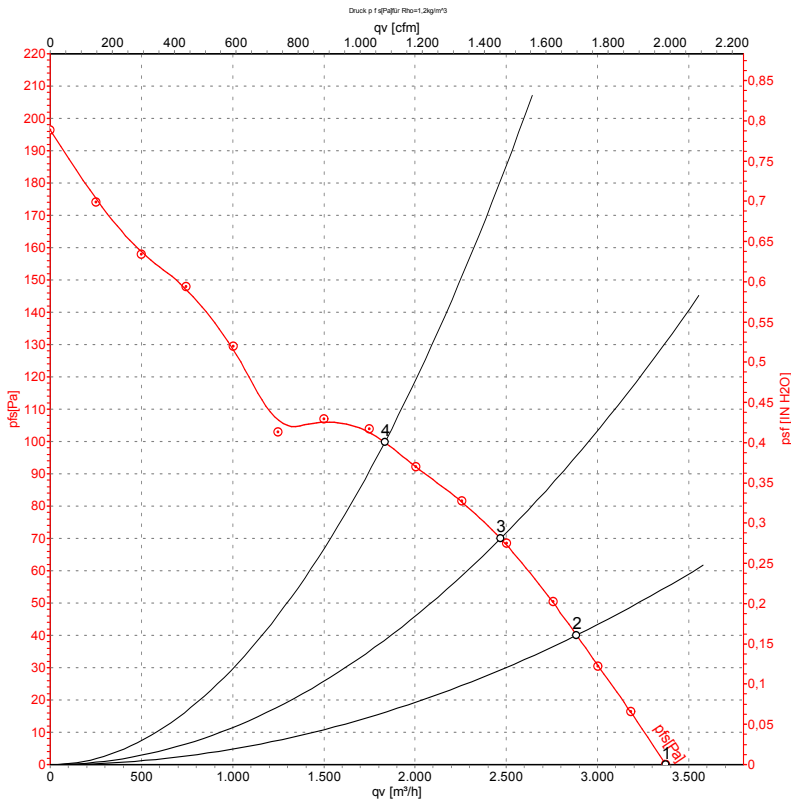

Measurement: LU-130206-1

Air performance measured according to ISO 5801 installation category A. For detailed information on the measurement setup, contact ebm-papst. Intake sound level: Sound power level according to ISO 13347 / sound pressure level measured at 1 m distance from fan axis. The values given are valid under the specified measuring conditions and may vary due to conditions of installation. For deviations from the standard configuration, the parameters have to be checked on the installed unit.

Measured values

	U	f	n	P _e	I	LpA _{in}	LwA _{in}	q _v	P _{fs}	q _v	P _{fs}
	V	Hz	min ⁻¹	W	A	dB(A)	dB(A)	m ³ /h	Pa	cfm	inH ₂ O
1	230	50	1435	143	0.68	62	70	3375	0	1985	0.00
2	230	50	1425	156	0.73	59	67	2885	40	1695	0.16
3	230	50	1415	166	0.76	56	64	2470	70	1455	0.28
4	230	50	1400	180	0.81	62	70	1835	100	1080	0.40

U = Power supply · f = Frequency · n = Speed (rpm) · P_e = Power consumption · I = Current draw · LpA_{in} = Sound pressure level intake side · LwA_{in} = Sound power level intake side
q_v = Air flow · P_{fs} = Pressure increase



AC axial fan

sickle-shaped blades (S series), single-intake
with guard grille for short nozzle

Curves: Air performance 60 Hz

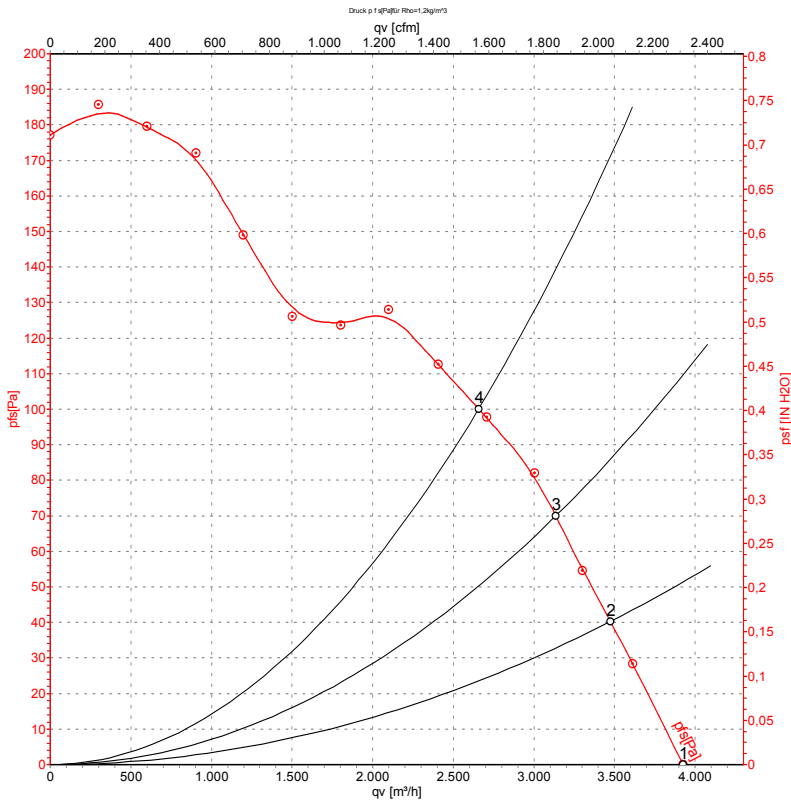

Measurement: LU-130207-1

Air performance measured according to ISO 5801 installation category A. For detailed information on the measurement setup, contact ebm-papst. Intake sound level: Sound power level according to ISO 13347 / sound pressure level measured at 1 m distance from fan axis. The values given are valid under the specified measuring conditions and may vary due to conditions of installation. For deviations from the standard configuration, the parameters have to be checked on the installed unit.

Measured values

	U	f	n	P _e	I	LpA _{in}	LwA _{in}	q _v	p _{is}	q _v	p _{is}
	V	Hz	min ⁻¹	W	A	dB(A)	dB(A)	m ³ /h	Pa	cfm	inH ₂ O
1	230	60	1675	204	0.89	66	74	3925	0	2310	0.00
2	230	60	1650	224	0.98	63	71	3475	40	2045	0.16
3	230	60	1635	234	1.02	61	69	3135	70	1845	0.28
4	230	60	1600	250	1.10	59	67	2655	100	1565	0.40

U = Power supply · f = Frequency · n = Speed (rpm) · P_e = Power consumption · I = Current draw · LpA_{in} = Sound pressure level intake side · LwA_{in} = Sound power level intake side
q_v = Air flow · p_{is} = Pressure increase

