

S4E350-AN02-41 ebmpapst Datasheet FansCo

sales@fansco.com

www.fansco.com

Nominal data

Type	S4E350-AN02-41	
Motor	M4E074-DF	
Phase		1~
Nominal voltage	VAC	230
Frequency	Hz	50
Method of obtaining data		ml
Valid for approval/standard		CE
Speed (rpm)	min ⁻¹	1340
Power consumption	W	165
Current draw	A	0.73
Capacitor	μF	4
Capacitor voltage	VDB	400
Capacitor standard		S0 (CE)
Max. back pressure	Pa	90
Max. back pressure	in. wg	0.36
Min. ambient temperature	°C	-25
Max. ambient temperature	°C	65
Starting current	A	1.4

ml = Max. load · me = Max. efficiency · fa = Free air · cs = Customer specification · ce = Customer equipment
Subject to change

Data according to Commission Regulation (EU) 327/2011

		Actual	Req. 2015
01 Overall efficiency η_{es}	%	29	28.6
02 Measurement category		A	
03 Efficiency category		Static	
04 Efficiency grade N		40.4	40
05 Variable speed drive		No	

Data obtained at optimum efficiency level.

The ErP data is determined using a motor-impeller combination in a standardized measurement setup.

09 Power consumption P_e	kW	0.16
09 Air flow q_v	m ³ /h	2160
09 Pressure increase p_{fs}	Pa	75
10 Speed (rpm) n	min ⁻¹	1355
11 Specific ratio*		1.00

* Specific ratio = $1 + p_g / 100\,000\text{ Pa}$

LU-131320



AC axial fan

sickle-shaped blades (S series)
with guard grille for short nozzle

Technical description

Weight	4.8 kg
Size	350 mm
Motor size	74
Rotor surface	Painted black
Terminal box material	PC/ABS plastic
Blade material	Press-fitted sheet steel blank, sprayed with PP plastic
Guard grille material	Steel, coated with black plastic (RAL 9005)
Number of blades	5
Airflow direction	V
Direction of rotation	Counterclockwise, viewed toward rotor
Degree of protection	IP44; installation- and position-dependent as per EN 60034-5
Insulation class	"F"
Moisture (F) / Environmental (H) protection class	H1
Max. permitted ambient temp. for motor (transport/storage)	+ 80 °C
Min. permitted ambient temp. for motor (transport/storage)	- 40 °C
Installation position	Shaft horizontal or rotor on bottom; rotor on top on request
Condensation drainage holes	On rotor side
Mode	S1
Motor bearing	Ball bearing
Touch current according to IEC 60990 (measuring circuit Fig. 4, TN system)	< 0.75 mA
Electrical hookup	Terminal box
Motor protection	Thermal overload protector (TOP) internally connected
With cable	Variable
Protection class	I (with customer connection of protective earth)
Motor capacitor according to EN 60252-1 in safety protection class	S0
Conformity with standards	EN 60335-1; CE
Approval	CSA C22.2 No. 100; UL 1004-1



AC axial fan

sickle-shaped blades (S series)
with guard grille for short nozzle

Product drawing

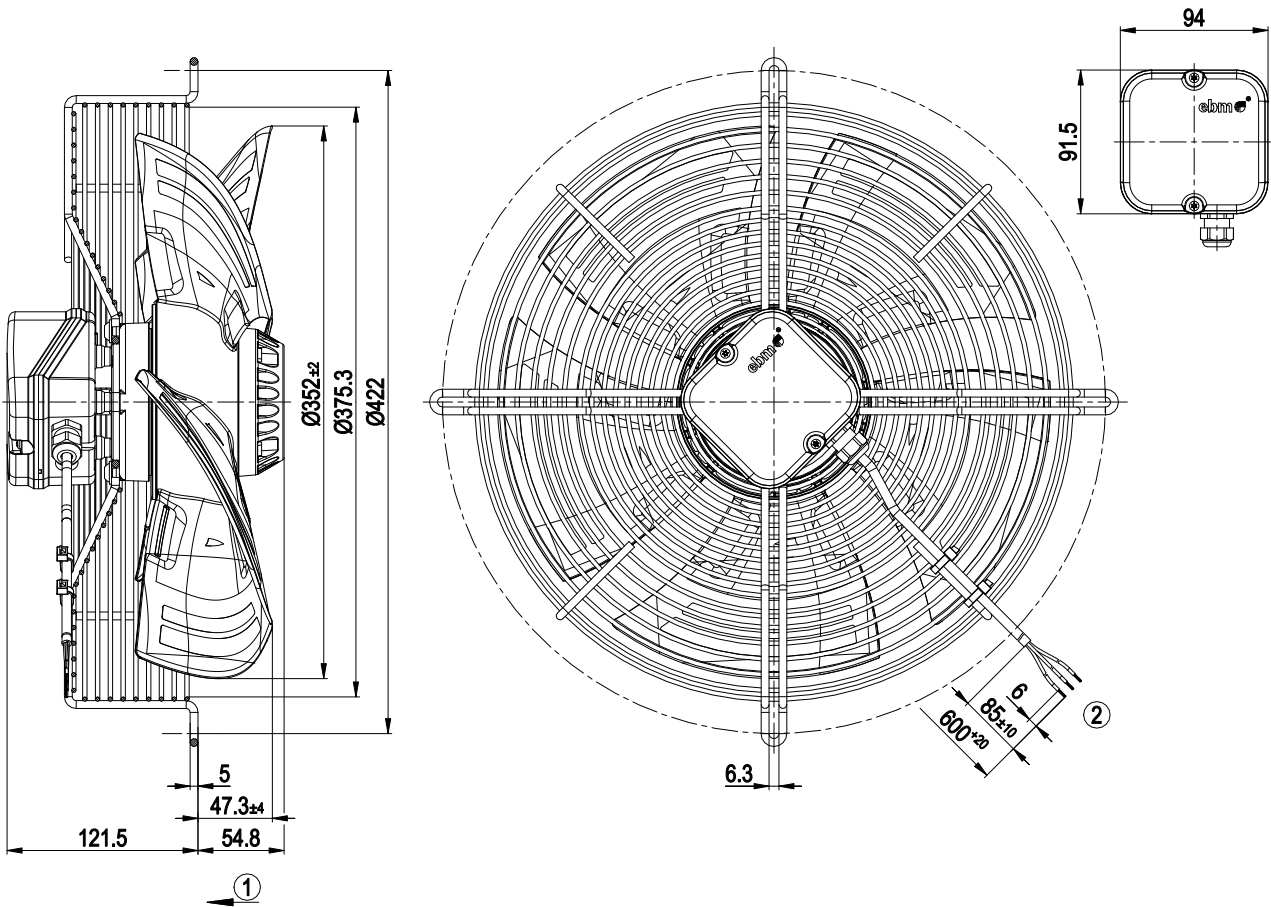

1	Airflow direction "V"
2	Cable PVC AWG20
	3x splice

Connection diagram

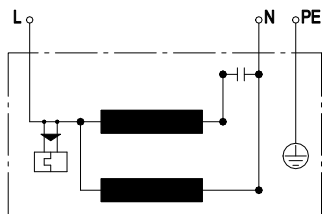

L	blue	N	black	PE	green/yellow
---	------	---	-------	----	--------------



AC axial fan

sickle-shaped blades (S series)
with guard grille for short nozzle

Curves: Air performance 50 Hz

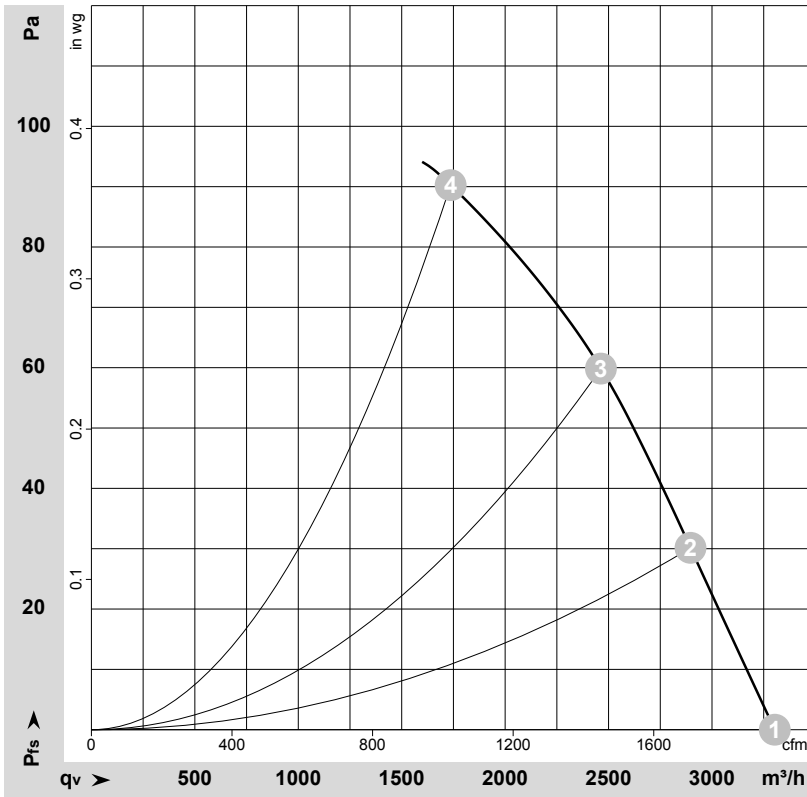

$\rho = 1.179 \text{ kg/m}^3 \pm 2 \%$

Measurement: LU-131320-1

Air performance measured according to ISO 5801 installation category A. For detailed information on the measurement setup, contact ebmpapst. Intake sound level: Sound power level according to ISO 13347 / sound pressure level measured at 1 m distance from fan axis. The values given are valid under the specified measuring conditions and may vary due to conditions of installation. For deviations from the standard configuration, the parameters have to be checked on the installed unit.

Measured values

	U	f	n	P _e	I	LpA _{in}	LwA _{in}	q _v	p _{fs}	q _v	p _{fs}
	V	Hz	min ⁻¹	W	A	dB(A)	dB(A)	m³/h	Pa	cfm	in. wg
1	230	50	1400	135	0.60	62	69	3305	0	1945	0.00
2	230	50	1380	145	0.64	59	67	2895	30	1705	0.12
3	230	50	1365	155	0.68	56	64	2465	60	1450	0.24
4	230	50	1340	165	0.73	58	66	1735	90	1020	0.36

U = Voltage · f = Frequency · n = Speed (rpm) · P_e = Power consumption · I = Current draw · LpA_{in} = Sound pressure level intake side · LwA_{in} = Sound power level intake side
q_v = Air flow · p_{fs} = Pressure increase

