

# AC axial fan

straight blades (A series)

with guard grille for short nozzle

S4E315-AB06-07 ebmpapst Datasheet

sales@fansco.com

www.fansco.com

Limited partnership · Headquarters Muldingen

Amtsgericht (court of registration) Stuttgart · HRA 590344

General partner Elektrobau Muldingen GmbH · Headquarters Muldingen

Amtsgericht (court of registration) Stuttgart · HRB 590142

## Nominal data

<b>Type</b>	<b>S4E315-AB06-07</b>		
<b>Motor</b>	<b>M4E068-CF</b>		
Phase		1~	1~
Nominal voltage	VAC	230	230
Frequency	Hz	50	60
Method of obtaining data		fa	fa
Valid for approval/standard		CE	CE
Speed (rpm)	min <sup>-1</sup>	1340	1490
Power consumption	W	96	130
Current draw	A	0.43	0.58
Capacitor	µF	3	3
Capacitor voltage	VDB	400	400
Capacitor standard		S0 (CE)	S0 (CE)
Max. back pressure	Pa	50	55
Max. back pressure	inH <sub>2</sub> O	0.2	0.22
Min. ambient temperature	°C	-40	-40
Max. ambient temperature	°C	40	35
Starting current	A	0.72	0.74

ml = Max. load · me = Max. efficiency · fa = Free air · cs = Customer specification · ce = Customer equipment  
Subject to change



# AC axial fan

straight blades (A series)  
with guard grille for short nozzle

## Technical description

Fan size	315 mm
Rotor surface	Painted black
Terminal box material	ABS plastic
Blade material	Sheet steel, galvanized
Guard grille material	Steel, phosphated and coated with white-aluminum plastic (RAL 9006)
Number of blades	5
Airflow direction	"V"
Direction of rotation	Counterclockwise, viewed toward rotor
Degree of protection	IP44; installation- and position-dependent as per EN 60034-5
Insulation class	"F"
Moisture (F) / Environmental (H) protection class	F5
Max. permitted ambient temp. for motor (transport/storage)	+ 80 °C
Min. permitted ambient temp. for motor (transport/storage)	- 40 °C
Installation position	Shaft horizontal or rotor on bottom; rotor on top on request
Condensation drainage holes	On rotor side
Mode	S1
Motor bearing	Ball bearing with low-temperature lubricant
Touch current according to IEC 60990 (measuring circuit Fig. 4, TN system)	< 0.75 mA
Electrical hookup	Via terminal box, capacitor integrated and connected
Motor protection	Thermal overload protector (TOP) internally connected
With cable	Variable
Protection class	I (with customer connection of protective earth)
Motor capacitor according to EN 60252-1 in safety protection class	S0
Conformity with standards	EN 60335-1; CE



# AC axial fan

straight blades (A series)  
with guard grille for short nozzle

## Product drawing

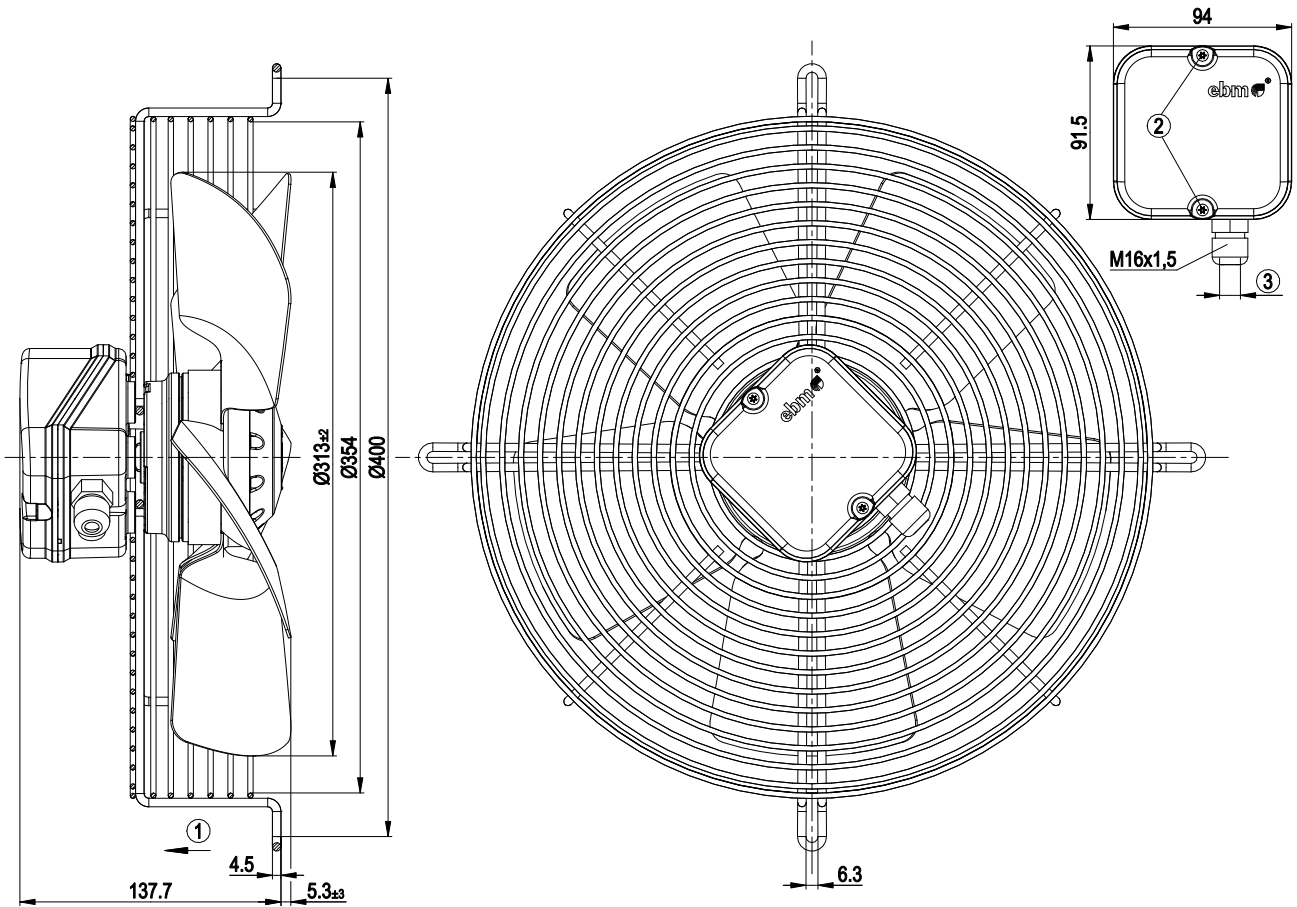

1	Direction of air flow "V"
2	Tightening torque $1.5 \pm 0.2$ Nm
3	Cable diameter: min. 6 mm, max. 12 mm, tightening torque $2 \pm 0.3$ Nm

## Connection diagram



L	= U1 = blue	Z	brown	N	= U2 = black
PE	green/yellow				



# AC axial fan

straight blades (A series)  
with guard grille for short nozzle

## Curves: Air performance 50 Hz

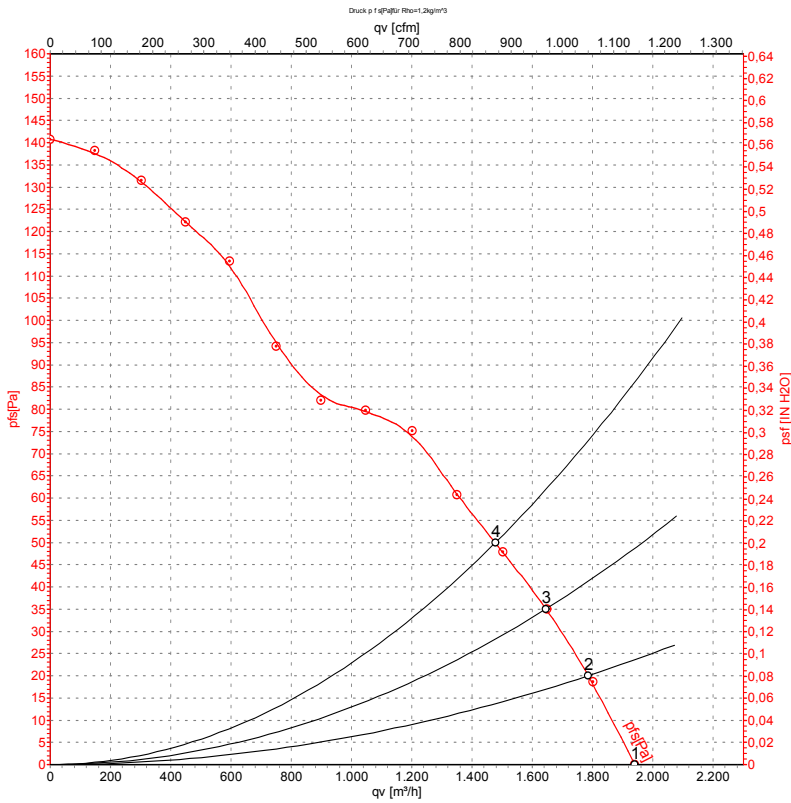

Measurement: LU-140155-1

Air performance measured according to ISO 5801 installation category A. For detailed information on the measurement setup, contact ebmpapst. Intake sound level: Sound power level according to ISO 13347 / sound pressure level measured at 1 m distance from fan axis. The values given are valid under the specified measuring conditions and may vary due to conditions of installation. For deviations from the standard configuration, the parameters have to be checked on the installed unit.

## Measured values

	U	f	n	P <sub>e</sub>	I	q <sub>v</sub>	P <sub>fs</sub>	q <sub>v</sub>	P <sub>fs</sub>
	V	Hz	min <sup>-1</sup>	W	A	m <sup>3</sup> /h	Pa	cfm	inH <sub>2</sub> O
1	230	50	1340	96	0.43	1940	0	1140	0.00
2	230	50	1330	95	0.42	1785	20	1050	0.08
3	230	50	1320	98	0.43	1645	35	970	0.14
4	230	50	1305	100	0.44	1475	50	870	0.20

U = Power supply · f = Frequency · n = Speed (rpm) · P<sub>e</sub> = Power consumption · I = Current draw · q<sub>v</sub> = Air flow · P<sub>fs</sub> = Pressure increase



# AC axial fan

straight blades (A series)  
with guard grille for short nozzle

## Curves: Air performance 60 Hz

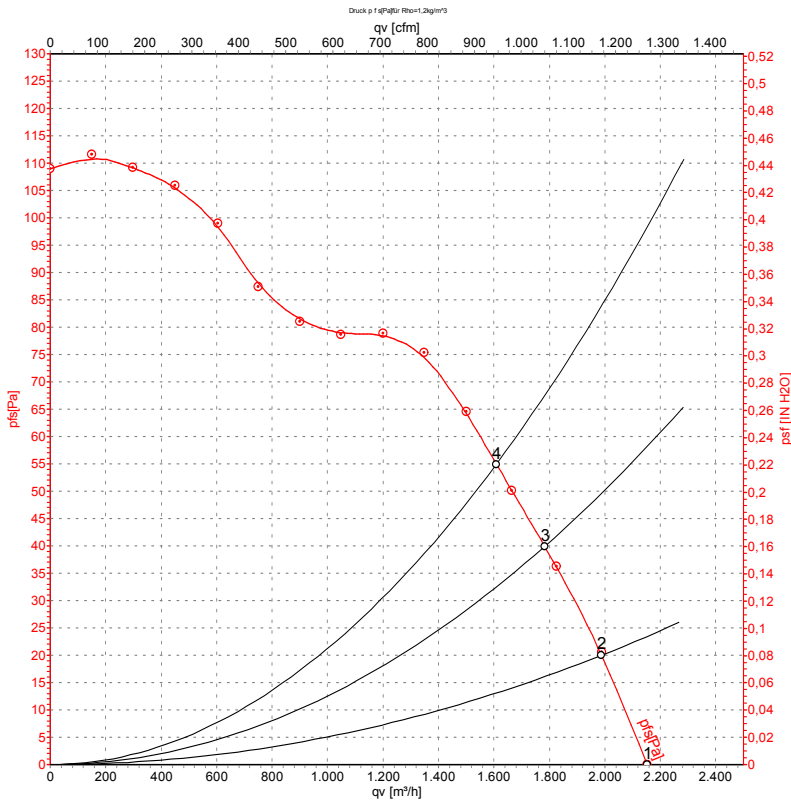

Measurement: LU-140156-1

Air performance measured according to ISO 5801 installation category A. For detailed information on the measurement setup, contact ebm-papst. Intake sound level: Sound power level according to ISO 13347 / sound pressure level measured at 1 m distance from fan axis. The values given are valid under the specified measuring conditions and may vary due to conditions of installation. For deviations from the standard configuration, the parameters have to be checked on the installed unit.

## Measured values

	U	f	n	P <sub>e</sub>	I	q <sub>v</sub>	p <sub>fs</sub>	q <sub>v</sub>	p <sub>fs</sub>
	V	Hz	min <sup>-1</sup>	W	A	m <sup>3</sup> /h	Pa	cfm	inH <sub>2</sub> O
1	230	60	1490	130	0.58	2150	0	1265	0.00
2	230	60	1455	127	0.56	1990	20	1170	0.08
3	230	60	1420	130	0.57	1785	40	1050	0.16
4	230	60	1395	132	0.58	1610	55	945	0.22

U = Power supply · f = Frequency · n = Speed (rpm) · P<sub>e</sub> = Power consumption · I = Current draw · q<sub>v</sub> = Air flow · p<sub>fs</sub> = Pressure increase

