

AC axial fan

straight blades (A series)

with guard grille for short nozzle

S4E315-AA02-39 ebmpapst Datasheet

sales@fansco.com

www.fansco.com

Limited partnership · Headquarters Muldingen

Amtsgericht (court of registration) Stuttgart · HRA 590344

General partner Elektrobau Muldingen GmbH · Headquarters Muldingen

Amtsgericht (court of registration) Stuttgart · HRB 590142

Nominal data

Type	S4E315-AA02-39		
Motor	M4E068-EC		
Phase		1~	1~
Nominal voltage	VAC	230	230
Frequency	Hz	50	60
Method of obtaining data		ce	ce
Valid for approval/standard		CE	CE
Speed (rpm)	min ⁻¹	1350	1470
Power consumption	W	92	125
Current draw	A	0.41	0.56
Capacitor	µF	3	3
Capacitor voltage	VDB	400	400
Min. ambient temperature	°C	-25	-25
Max. ambient temperature	°C	85	70

ml = Max. load · me = Max. efficiency · fa = Free air · cs = Customer specification · ce = Customer equipment
Subject to change



AC axial fan

straight blades (A series)

with guard grille for short nozzle

Technical description

Weight	4 kg
Fan size	315 mm
Rotor surface	Painted black
Terminal box material	PC/ABS plastic, black
Impeller material	Sheet steel, hot-dip galvanized
Guard grille material	Steel, phosphated and coated with black plastic
Number of blades	5
Airflow direction	"V"
Direction of rotation	Counterclockwise, viewed toward rotor
Degree of protection	IP44
Insulation class	"F"
Moisture (F) / Environmental (H) protection class	H0+
Max. permitted ambient temp. for motor (transport/storage)	+ 80 °C
Min. permitted ambient temp. for motor (transport/storage)	- 40 °C
Installation position	Shaft horizontal or rotor on bottom; rotor on top on request
Condensation drainage holes	On rotor side
Mode	S1
Motor bearing	Ball bearing
Touch current according to IEC 60990 (measuring circuit Fig. 4, TN system)	< 0.75 mA
Electrical hookup	Via terminal box, capacitor integrated and connected
Motor protection	Thermal overload protector (TOP) internally connected
With cable	Axial
Protection class	I (with customer connection of protective earth)
Motor capacitor according to EN 60252-1 in safety protection class	S0
Conformity with standards	EN 60335-1; CE
Approval	UL 1004-1; CSA C22.2 No. 100; EAC; CCC



AC axial fan

straight blades (A series)
with guard grille for short nozzle

Product drawing

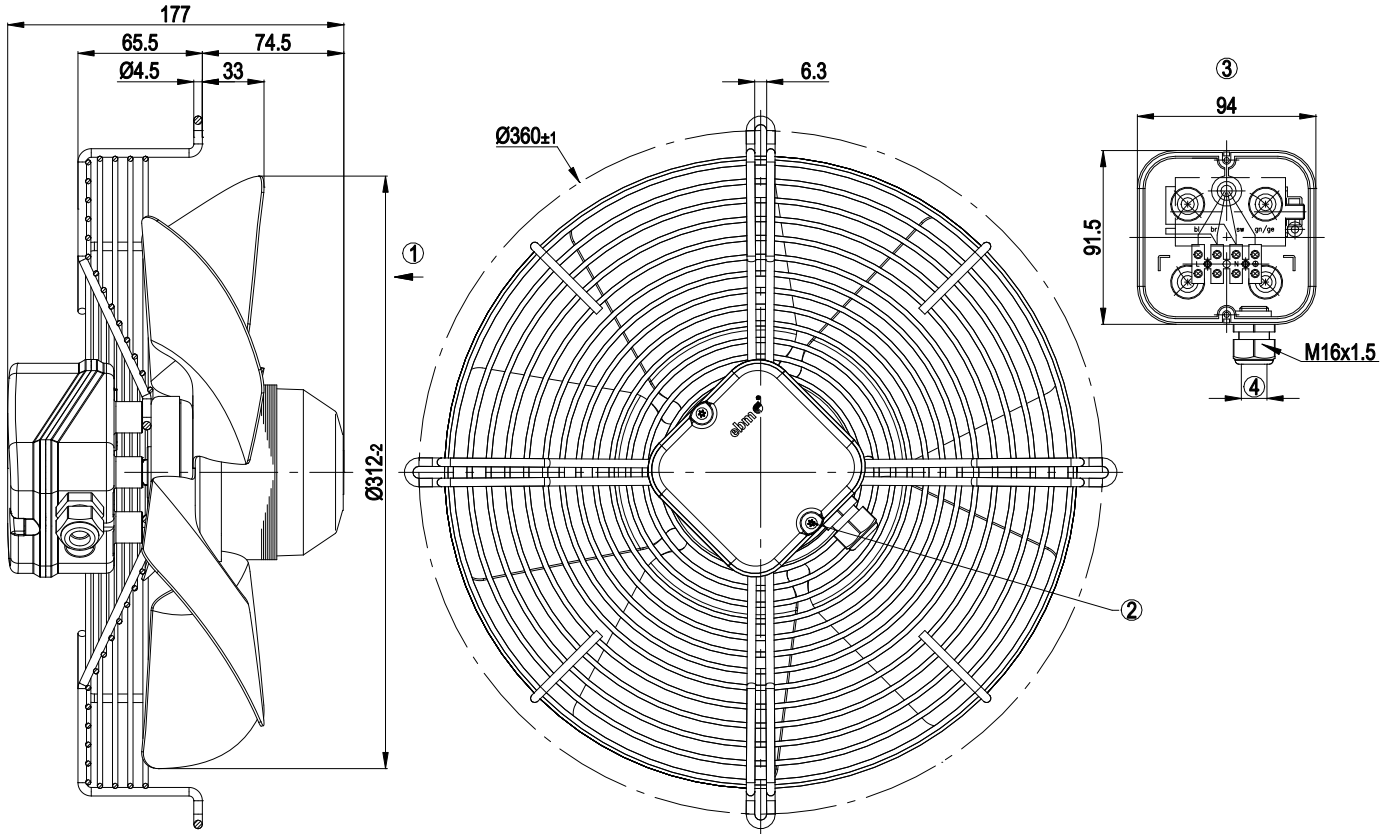

1	Direction of air flow "V"
2	Tightening torque 0.7 Nm
3	Shown without terminal box cover
4	Cable diameter: min. 4 mm, max. 8 mm; tightening torque 1.3 Nm

Connection diagram

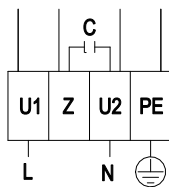

L	= U1 = blue	Z	brown	N	= U2 = black
PE	green/yellow				



AC axial fan

straight blades (A series)
with guard grille for short nozzle

Curves: Air performance 50 Hz

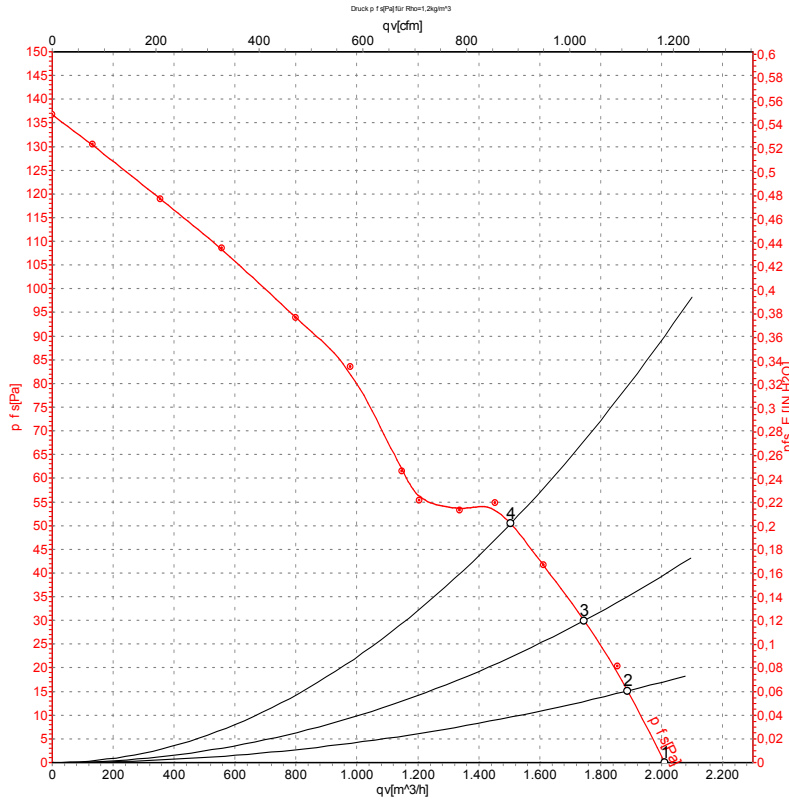

Measurement: LU-56282-1

Air performance measured according to ISO 5801 installation category A. For detailed information on the measurement setup, contact ebm-papst. Intake sound level: Sound power level according to ISO 13347 / sound pressure level measured at 1 m distance from fan axis. The values given are valid under the specified measuring conditions and may vary due to conditions of installation. For deviations from the standard configuration, the parameters have to be checked on the installed unit.

Measured values

	U	f	n	P _e	I	q _v	P _{fs}	q _v	P _{fs}
	V	Hz	min ⁻¹	W	A	m ³ /h	Pa	cfm	inH ₂ O
1	230	50	1375	85	0.38	2010	0	1185	0.00
2	230	50	1365	88	0.39	1890	15	1110	0.06
3	230	50	1350	91	0.40	1745	30	1030	0.12
4	230	50	1350	92	0.41	1505	50	885	0.20

U = Power supply · f = Frequency · n = Speed (rpm) · P_e = Power consumption · I = Current draw · q_v = Air flow · P_{fs} = Pressure increase



AC axial fan

straight blades (A series)
with guard grille for short nozzle

Curves: Air performance 60 Hz

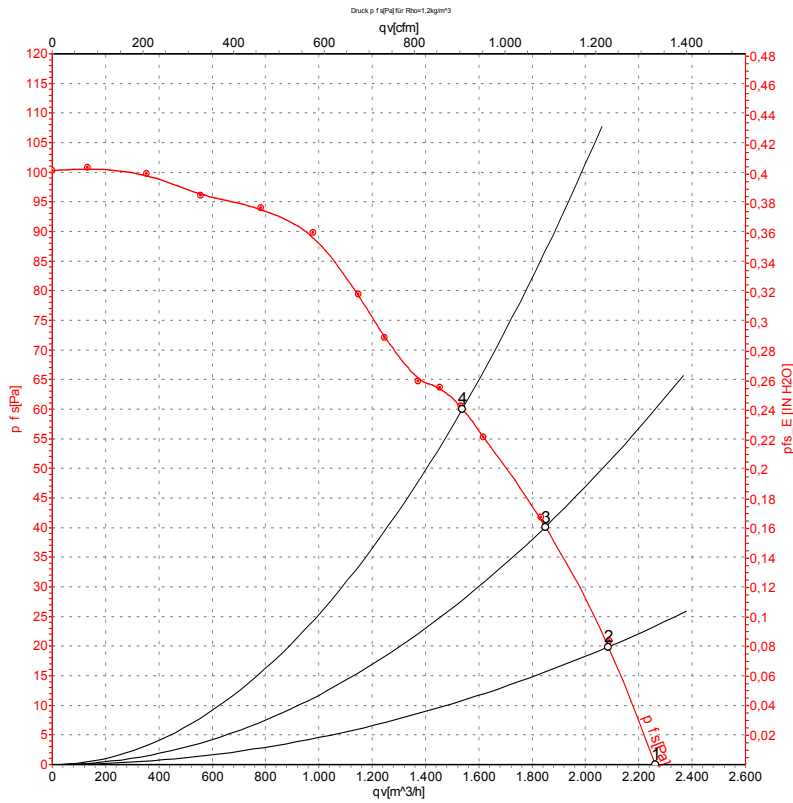

Measurement: LU-56283-1

Air performance measured according to ISO 5801 installation category A. For detailed information on the measurement setup, contact ebm-papst. Intake sound level: Sound power level according to ISO 13347 / sound pressure level measured at 1 m distance from fan axis. The values given are valid under the specified measuring conditions and may vary due to conditions of installation. For deviations from the standard configuration, the parameters have to be checked on the installed unit.

Measured values

	U	f	n	P _e	I	q _v	P _{fs}	q _v	P _{fs}
	V	Hz	min ⁻¹	W	A	m ³ /h	Pa	cfm	inH ₂ O
1	230	60	1550	116	0.51	2260	0	1330	0.00
2	230	60	1515	120	0.52	2085	20	1230	0.08
3	230	60	1470	124	0.54	1850	40	1090	0.16
4	230	60	1470	125	0.56	1540	60	905	0.24

U = Power supply · f = Frequency · n = Speed (rpm) · P_e = Power consumption · I = Current draw · q_v = Air flow · P_{fs} = Pressure increase

