

AC axial fan

sickle-shaped blades (S series)
with guard grille for short nozzle

S4E300-AR26-37 ebmpapst Datasheet

sales@fansco.com

www.fansco.com

Limited partnership · Headquarters Muldingen

Amtsgericht (court of registration) Stuttgart · HRA 590344

General partner Elektrobau Muldingen GmbH · Headquarters Muldingen

Amtsgericht (court of registration) Stuttgart · HRB 590142

Nominal data

Type	S4E300-AR26-37		
Motor	M4E068-CF		
Phase		1~	1~
Nominal voltage	VAC	230	230
Frequency	Hz	50	60
Method of obtaining data		fa	fa
Valid for approval/standard		CE	CE
Speed (rpm)	min ⁻¹	1380	1570
Power consumption	W	70	95
Current draw	A	0.32	0.42
Capacitor	µF	2	2
Capacitor voltage	VDB	400	400
Max. back pressure	Pa	60	70
Max. back pressure	inH ₂ O	0.24	0.28
Min. ambient temperature	°C	-25	-25
Max. ambient temperature	°C	55	45
Starting current	A	0.64	0.64

ml = Max. load · me = Max. efficiency · fa = Free air · cs = Customer specification · ce = Customer equipment
Subject to change



AC axial fan

sickle-shaped blades (S series)
with guard grille for short nozzle

Technical description

Weight	3.0 kg
Fan size	300 mm
Rotor surface	Painted black
Terminal box material	ABS plastic
Blade material	Sheet steel, painted black
Guard grille material	Steel, coated with black plastic (RAL 9005)
Number of blades	5
Airflow direction	"V"
Direction of rotation	Counterclockwise, viewed toward rotor
Degree of protection	IP44; installation- and position-dependent as per EN 60034-5
Insulation class	"B"
Moisture (F) / Environmental (H) protection class	H0+
Max. permitted ambient temp. for motor (transport/storage)	+ 80 °C
Min. permitted ambient temp. for motor (transport/storage)	- 40 °C
Installation position	Shaft horizontal or rotor on bottom; rotor on top on request
Condensation drainage holes	On rotor side
Mode	S1
Motor bearing	Ball bearing
Touch current according to IEC 60990 (measuring circuit Fig. 4, TN system)	< 0.75 mA
Electrical hookup	Via terminal box, capacitor integrated and connected
Motor protection	Thermal overload protector (TOP) internally connected
With cable	Variable
Protection class	I (with customer connection of protective earth)
Motor capacitor according to EN 60252-1 in safety protection class	S0
Conformity with standards	EN 60335-1; CE



AC axial fan

sickle-shaped blades (S series)
with guard grille for short nozzle

Product drawing

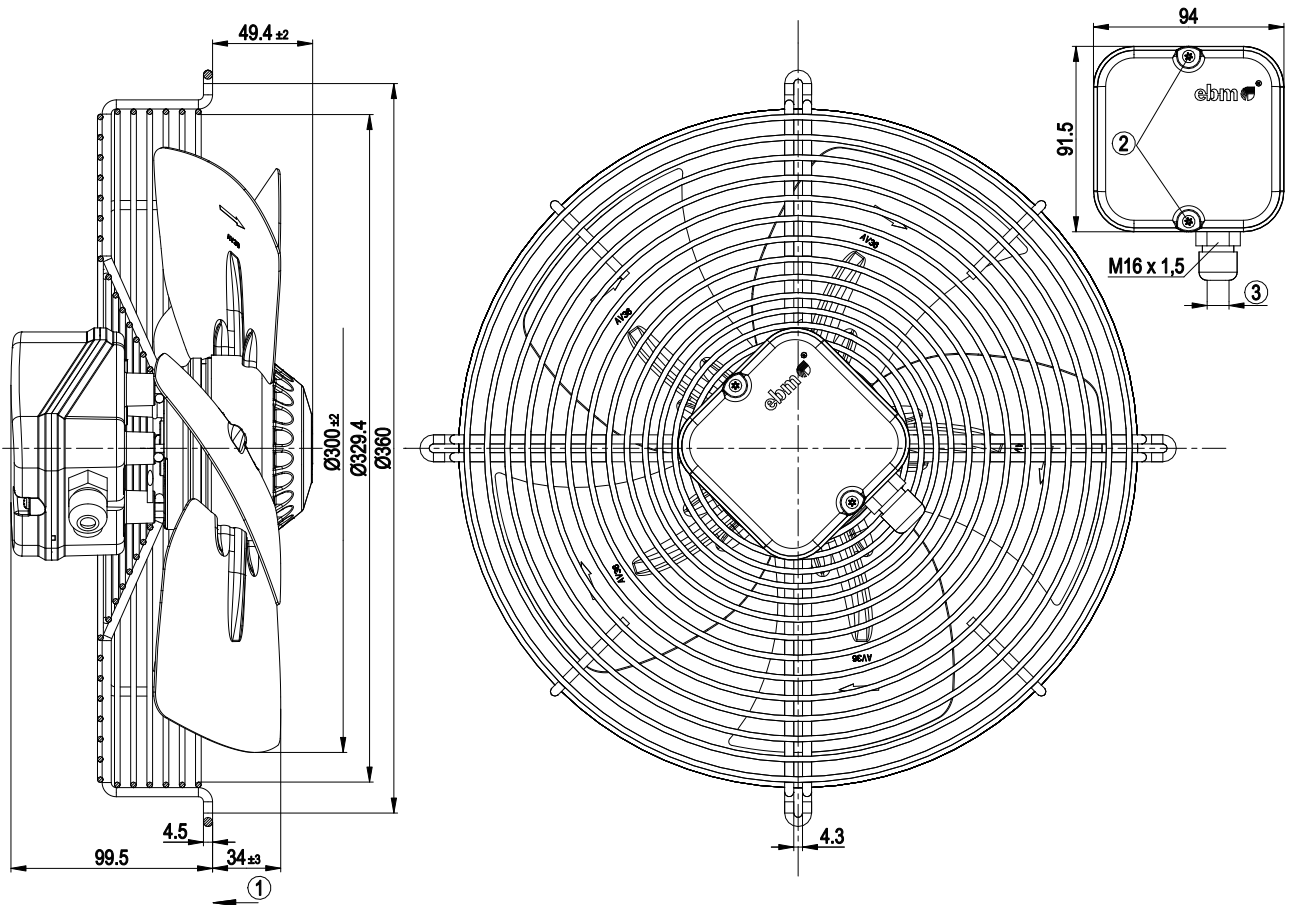

- | | |
|---|--|
| 1 | Direction of air flow "V" |
| 2 | Tightening torque 1.3 ± 0.2 Nm |
| 3 | Cable diameter: 7.5 mm; tightening torque 2 ± 0.3 Nm |

Connection diagram

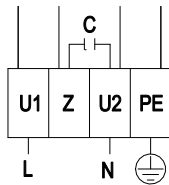

L	= U1 = blue	Z	brown	N	= U2 = black
PE	green/yellow				



AC axial fan

sickle-shaped blades (S series)
with guard grille for short nozzle

Curves: Air performance 50 Hz

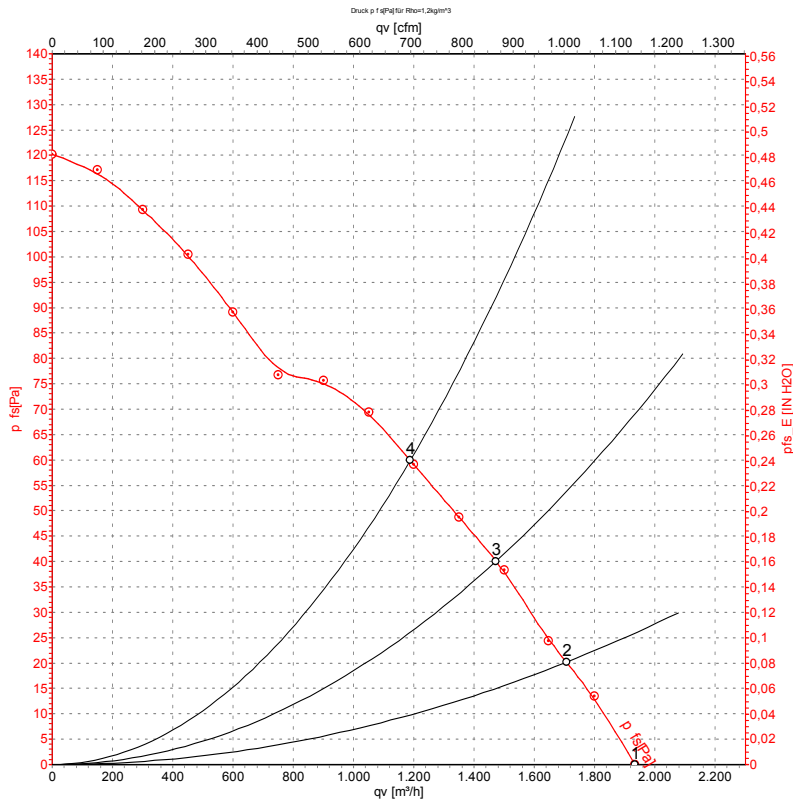

Measurement: LU-74683-1

Air performance measured according to ISO 5801 installation category A. For detailed information on the measurement setup, contact ebm-papst. Intake sound level: Sound power level according to ISO 13347 / sound pressure level measured at 1 m distance from fan axis. The values given are valid under the specified measuring conditions and may vary due to conditions of installation. For deviations from the standard configuration, the parameters have to be checked on the installed unit.

Measured values

	U	f	n	P _e	I	LpA _{in}	q _v	P _{fs}	q _v	P _{fs}
	V	Hz	min ⁻¹	W	A	dB(A)	m ³ /h	Pa	cfm	inH ₂ O
1	230	50	1380	70	0.32	57	1935	0	1140	0.00
2	230	50	1370	72	0.32	57	1705	20	1005	0.08
3	230	50	1355	76	0.33	55	1470	40	865	0.16
4	230	50	1335	79	0.35	52	1190	60	700	0.24

U = Power supply · f = Frequency · n = Speed (rpm) · P_e = Power consumption · I = Current draw · LpA_{in} = Sound pressure level intake side · q_v = Air flow · P_{fs} = Pressure increase



AC axial fan

sickle-shaped blades (S series)
with guard grille for short nozzle

Curves: Air performance 60 Hz

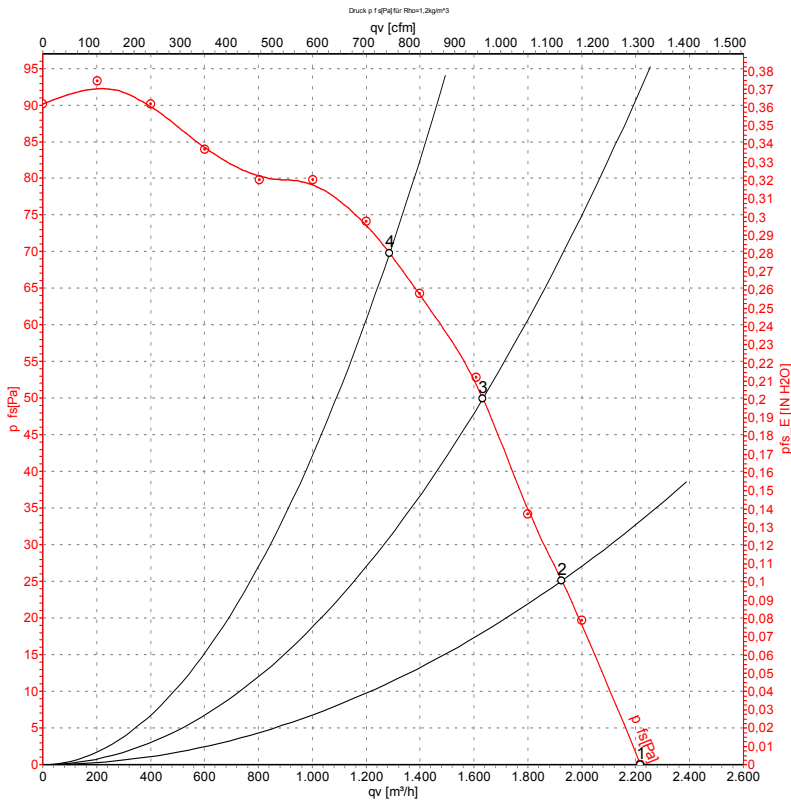

Measurement: LU-74684-1

Air performance measured according to ISO 5801 installation category A. For detailed information on the measurement setup, contact ebm-papst. Intake sound level: Sound power level according to ISO 13347 / sound pressure level measured at 1 m distance from fan axis. The values given are valid under the specified measuring conditions and may vary due to conditions of installation. For deviations from the standard configuration, the parameters have to be checked on the installed unit.

Measured values

	U	f	n	P _e	I	LpA _{in}	q _v	p _{fs}	q _v	p _{fs}
	V	Hz	min ⁻¹	W	A	dB(A)	m ³ /h	Pa	cfm	inH2O
1	230	60	1570	95	0.42	61	2215	0	1305	0.00
2	230	60	1545	99	0.43	60	1925	25	1135	0.10
3	230	60	1500	103	0.45	58	1635	50	960	0.20
4	230	60	1440	108	0.47	55	1285	70	755	0.28

U = Power supply · f = Frequency · n = Speed (rpm) · P_e = Power consumption · I = Current draw · LpA_{in} = Sound pressure level intake side · q_v = Air flow · p_{fs} = Pressure increase

