

AC axial fan

sickle-shaped blades (S series)

with guard grille for full nozzle

S4E250-BH02-01 ebmpapst Datasheet

sales@fansco.com

www.fansco.com

Limited partnership · Headquarters Mulfingen

Amtsgericht (court of registration) Stuttgart · HRA 590344

General partner Elektrobau Mulfingen GmbH · Headquarters Mulfingen

Amtsgericht (court of registration) Stuttgart · HRB 590142

Nominal data

Type	S4E250-BH02-01		
Motor	M4E068-BF		
Phase		1~	1~
Nominal voltage	VAC	230	230
Frequency	Hz	50	60
Method of obtaining data		fa	fa
Valid for approval/standard		CE	CE
Speed (rpm)	min ⁻¹	1400	1630
Power consumption	W	42	45
Current draw	A	0.19	0.20
Capacitor	µF	1.5	1.5
Capacitor voltage	VDB	400	400
Capacitor standard		S0 (CE)	
Max. back pressure	Pa	80	100
Max. back pressure	inH ₂ O	0.32	0.4
Min. ambient temperature	°C	-25	-25
Max. ambient temperature	°C	55	70
Starting current	A	0.33	0.32

ml = Max. load · me = Max. efficiency · fa = Free air · cs = Customer specification · ce = Customer equipment
Subject to change



AC axial fan

sickle-shaped blades (S series)

with guard grille for full nozzle

Technical description

Weight	1.86 kg
Fan size	250 mm
Rotor surface	Painted black
Blade material	Sheet steel, painted black
Guard grille material	Steel, phosphated and coated with black plastic
Number of blades	7
Airflow direction	"V"
Direction of rotation	Counterclockwise, viewed toward rotor
Degree of protection	IP44
Insulation class	"B"
Moisture (F) / Environmental (H) protection class	F5
Max. permitted ambient temp. for motor (transport/storage)	+ 80 °C
Min. permitted ambient temp. for motor (transport/storage)	- 40 °C
Installation position	Shaft horizontal or rotor on bottom; rotor on top on request
Condensation drainage holes	On rotor side
Mode	S1
Motor bearing	Ball bearing
Touch current according to IEC 60990 (measuring circuit Fig. 4, TN system)	< 0.75 mA
Motor protection	Thermal overload protector (TOP) internally connected
With cable	Variable
Protection class	I (with customer connection of protective earth)
Conformity with standards	EN 60335-1; CE
Approval	CCC; EAC



AC axial fan

sickle-shaped blades (S series)
with guard grille for full nozzle

Product drawing

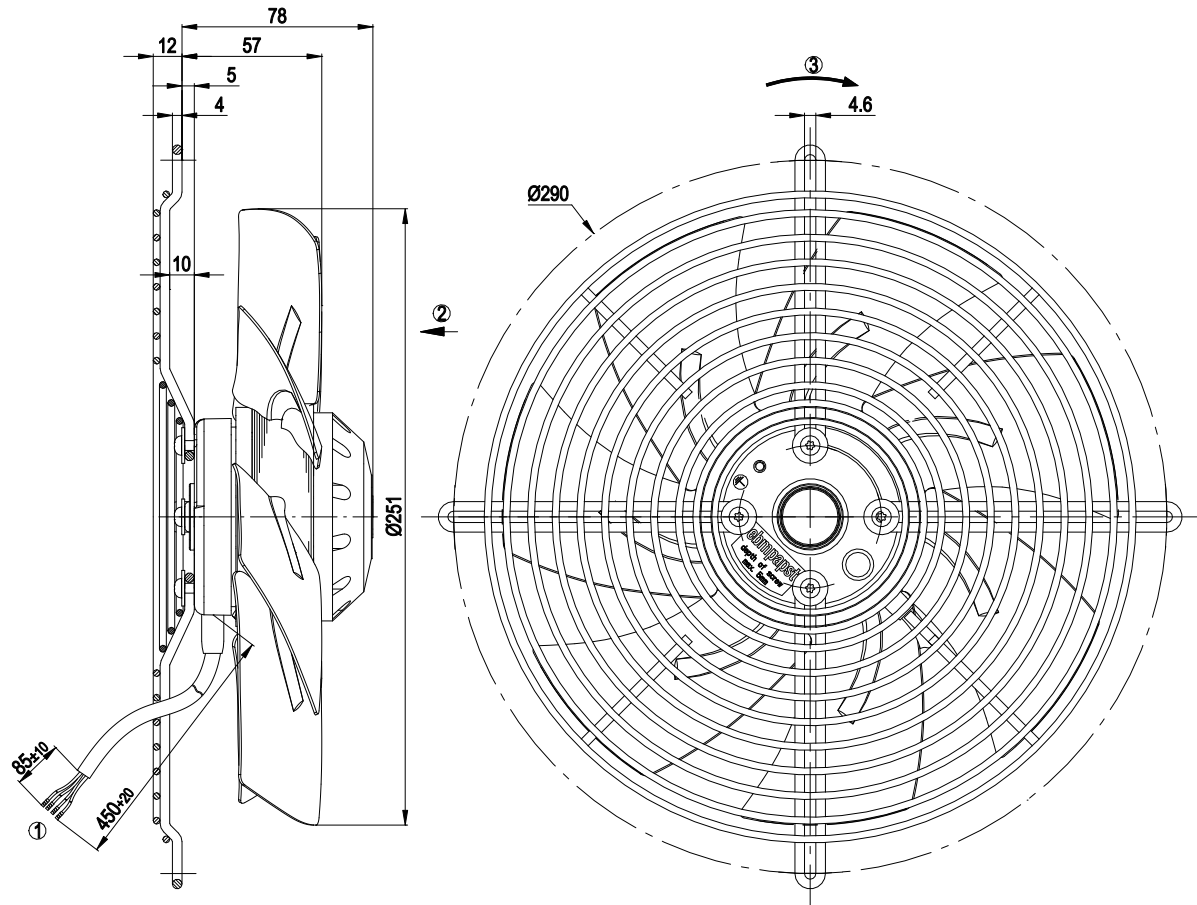

1	Cable PVC, 4x crimped splices
2	Direction of air flow "V"
3	Direction of rotation counterclockwise, viewed toward rotor

Connection diagram

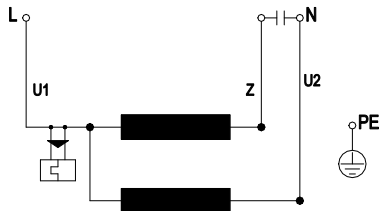

U1	blue	Z	brown	U2	black
PE	green/yellow				



AC axial fan

sickle-shaped blades (S series)
with guard grille for full nozzle

Curves: Air performance 50 Hz

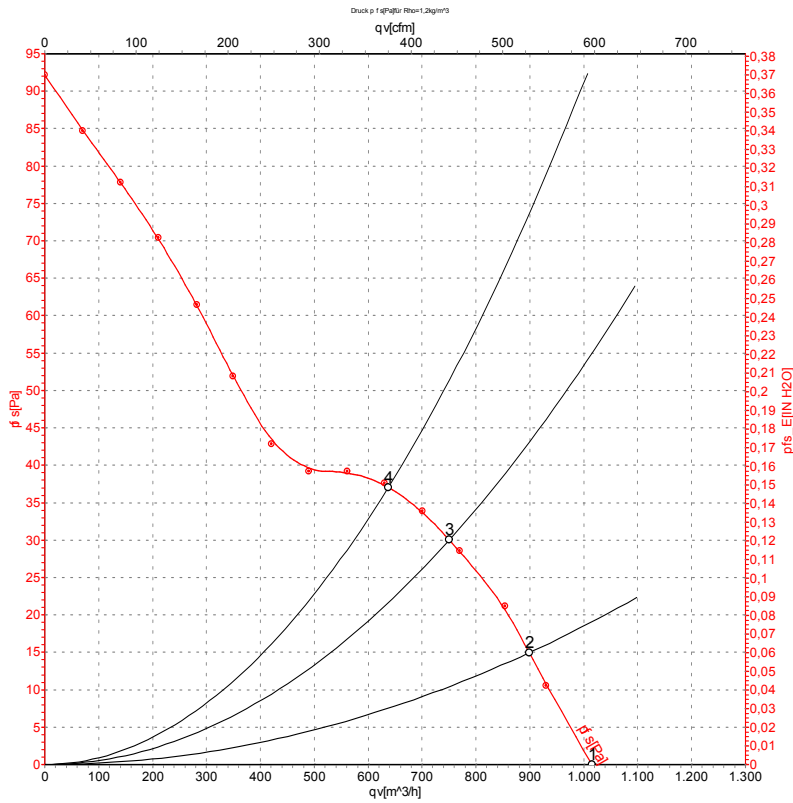

Measurement: LU-60036-1

Air performance measured according to ISO 5801 installation category A. For detailed information on the measurement setup, contact ebm-papst. Intake sound level: Sound power level according to ISO 13347 / sound pressure level measured at 1 m distance from fan axis. The values given are valid under the specified measuring conditions and may vary due to conditions of installation. For deviations from the standard configuration, the parameters have to be checked on the installed unit.

Measured values

	U	f	n	P _e	I	q _v	p _{fs}	q _v	p _{fs}
	V	Hz	min ⁻¹	W	A	m ³ /h	Pa	cfm	inH ₂ O
1	230	50	1400	42	0.19	1015	0	595	0.00
2	230	50	1385	43	0.20	900	15	530	0.06
3	230	50	1370	44	0.20	750	30	440	0.12
4	230	50	1350	45	0.22	640	35	375	0.14

U = Power supply · f = Frequency · n = Speed (rpm) · P_e = Power consumption · I = Current draw · q_v = Air flow · p_{fs} = Pressure increase



AC axial fan

sickle-shaped blades (S series)
with guard grille for full nozzle

Curves: Air performance 60 Hz

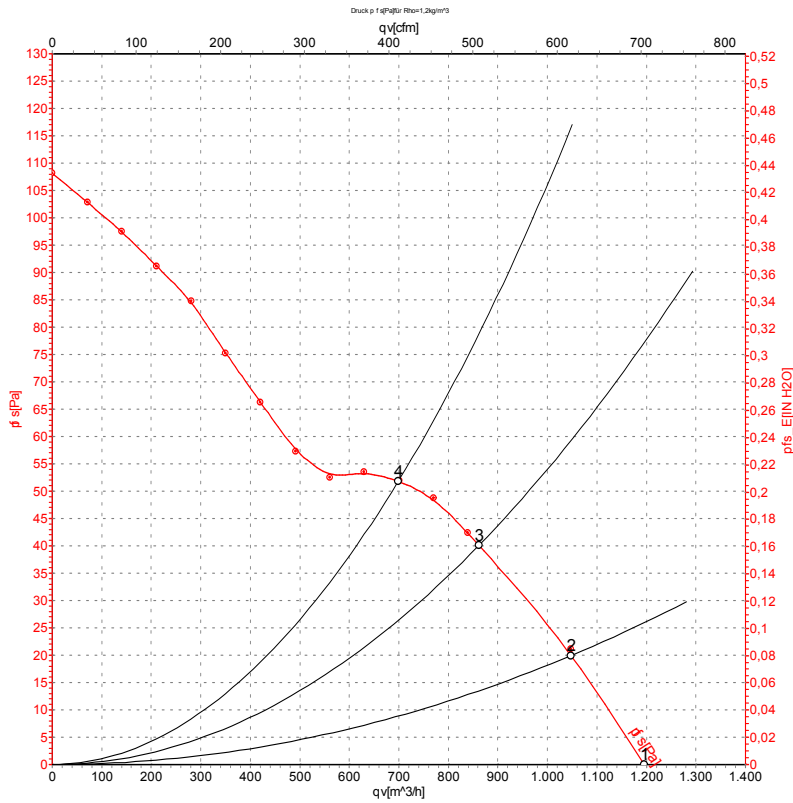

Measurement: LU-60037-1

Air performance measured according to ISO 5801 installation category A. For detailed information on the measurement setup, contact ebm-papst. Intake sound level: Sound power level according to ISO 13347 / sound pressure level measured at 1 m distance from fan axis. The values given are valid under the specified measuring conditions and may vary due to conditions of installation. For deviations from the standard configuration, the parameters have to be checked on the installed unit.

Measured values

	U	f	n	P _e	I	q _v	p _{fs}	q _v	p _{fs}
	V	Hz	min ⁻¹	W	A	m ³ /h	Pa	cfm	inH2O
1	230	60	1630	45	0.20	1200	0	705	0.00
2	230	60	1625	47	0.21	1045	20	615	0.08
3	230	60	1570	49	0.21	860	40	505	0.16
4	230	60	1570	50	0.23	700	50	410	0.20

U = Power supply · f = Frequency · n = Speed (rpm) · P_e = Power consumption · I = Current draw · q_v = Air flow · p_{fs} = Pressure increase

