

S4E250-AM02-05 ebmpapst Datasheet
 sales@fansco.com
 www.fansco.com

Limited partnership · Headquarters Muldingen
 Amtsgericht (court of registration) Stuttgart · HRA 590344
 General partner Elektrobau Muldingen GmbH · Headquarters Muldingen
 Amtsgericht (court of registration) Stuttgart · HRB 590142

Nominal data

| Type | S4E250-AM02-05 | | |
|-----------------------------|--------------------|---------|---------|
| Motor | M4E068-BF | | |
| Phase | | 1~ | 1~ |
| Nominal voltage | VAC | 230 | 230 |
| Frequency | Hz | 50 | 60 |
| Method of obtaining data | | ml | ml |
| Valid for approval/standard | | CE | CE |
| Speed (rpm) | min ⁻¹ | 1380 | 1610 |
| Power consumption | W | 45 | 48 |
| Current draw | A | 0.21 | 0.22 |
| Capacitor | µF | 1.5 | 1.5 |
| Capacitor voltage | VDB | 400 | 400 |
| Capacitor standard | | S0 (CE) | S0 (CE) |
| Max. back pressure | Pa | 40 | 54 |
| Max. back pressure | inH ₂ O | 0.16 | 0.22 |
| Min. ambient temperature | °C | -25 | -25 |
| Max. ambient temperature | °C | 30 | 50 |
| Starting current | A | 0.34 | 0.34 |

ml = Max. load · me = Max. efficiency · fa = Free air · cs = Customer specification · ce = Customer equipment
 Subject to change



Technical description

| | |
|--|--|
| Weight | 2 kg |
| Fan size | 250 mm |
| Rotor surface | Painted black |
| Terminal box material | ABS plastic, black |
| Blade material | PP plastic |
| Guard grille material | Steel, phosphated and coated with black plastic |
| Number of blades | 9 |
| Airflow direction | "V" |
| Direction of rotation | Counterclockwise, viewed toward rotor |
| Degree of protection | IP44 |
| Insulation class | "B" |
| Moisture (F) / Environmental (H) protection class | F2-2 |
| Max. permitted ambient temp. for motor (transport/storage) | + 70 °C |
| Min. permitted ambient temp. for motor (transport/storage) | - 40 °C |
| Installation position | Shaft horizontal or rotor on bottom; rotor on top on request |
| Condensation drainage holes | On rotor side |
| Mode | S1 |
| Motor bearing | Ball bearing with low-temperature lubricant |
| Touch current according to IEC 60990 (measuring circuit Fig. 4, TN system) | < 0.75 mA |
| Electrical hookup | Via terminal box, capacitor integrated and connected |
| Motor protection | Thermal overload protector (TOP) internally connected |
| With cable | Variable |
| Protection class | I (with customer connection of protective earth) |
| Motor capacitor according to EN 60252-1 in safety protection class | S0 |
| Conformity with standards | EN 60335-1; CE |



Product drawing

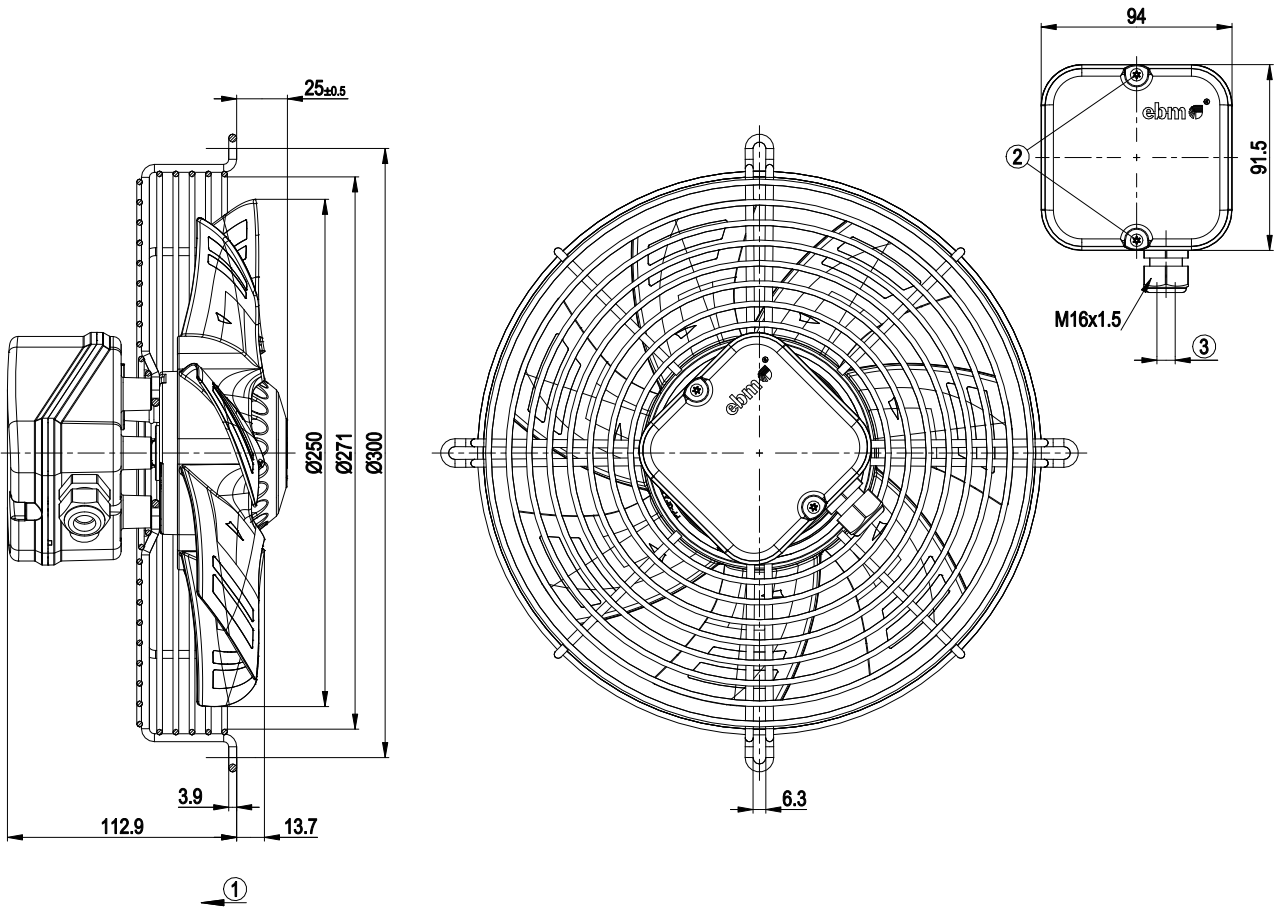

| | |
|---|--|
| 1 | Direction of air flow "V" |
| 2 | Tightening torque 0.5 ± 0.1 Nm |
| 3 | Cable diameter max. 7.5 mm, tightening torque 1.3 ± 0.2 Nm |

Connection diagram

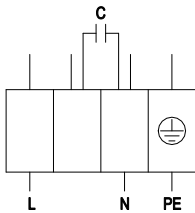

| | | | | | |
|----|--------------|---|-------|---|------|
| PE | green/yellow | L | black | N | blue |
|----|--------------|---|-------|---|------|



Curves: Air performance 50 Hz

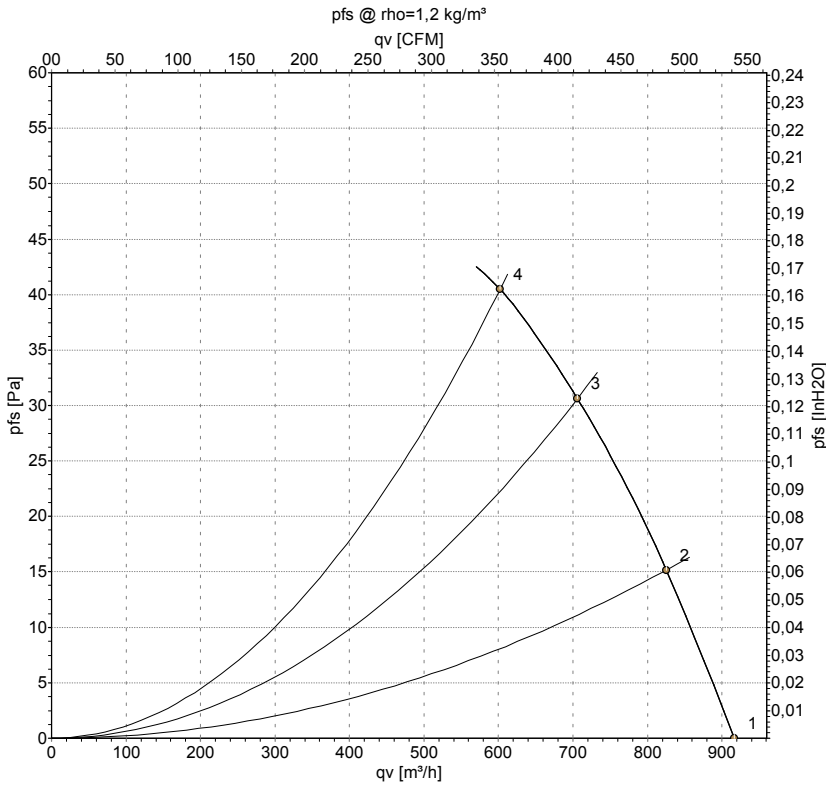

Measurement: LU-154668-1

Air performance measured according to ISO 5801 installation category A. For detailed information on the measurement setup, contact ebm-papst. Intake sound level: Sound power level according to ISO 13347 / sound pressure level measured at 1 m distance from fan axis. The values given are valid under the specified measuring conditions and may vary due to conditions of installation. For deviations from the standard configuration, the parameters have to be checked on the installed unit.

Measured values

| | U | f | n | P _e | I | LpA _{in} | LwA _{in} | q _v | p _{fs} | q _v | p _{fs} |
|---|-----|----|-------------------|----------------|------|-------------------|-------------------|-------------------|-----------------|----------------|--------------------|
| | V | Hz | min ⁻¹ | W | A | dB(A) | dB(A) | m ³ /h | Pa | cfm | inH ₂ O |
| 1 | 230 | 50 | 1415 | 43 | 0.20 | 48 | 55 | 915 | 0 | 540 | 0.00 |
| 2 | 230 | 50 | 1400 | 43 | 0.20 | 49 | 56 | 825 | 15 | 485 | 0.06 |
| 3 | 230 | 50 | 1390 | 44 | 0.20 | 50 | 57 | 705 | 30 | 415 | 0.12 |
| 4 | 230 | 50 | 1380 | 45 | 0.21 | 52 | 59 | 600 | 40 | 355 | 0.16 |

U = Power supply · f = Frequency · n = Speed (rpm) · P_e = Power consumption · I = Current draw · LpA_{in} = Sound pressure level intake side · LwA_{in} = Sound power level intake side
 q_v = Air flow · p_{fs} = Pressure increase



Curves: Air performance 60 Hz

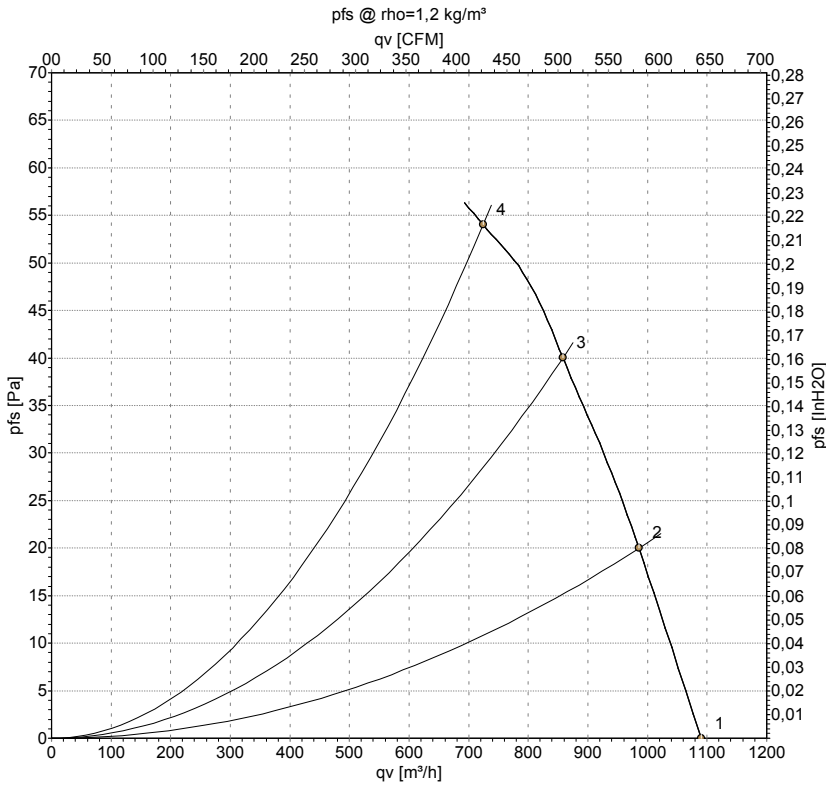

Measurement: LU-154670-1

Air performance measured according to ISO 5801 installation category A. For detailed information on the measurement setup, contact ebmpapst. Intake sound level: Sound power level according to ISO 13347 / sound pressure level measured at 1 m distance from fan axis. The values given are valid under the specified measuring conditions and may vary due to conditions of installation. For deviations from the standard configuration, the parameters have to be checked on the installed unit.

Measured values

| | U | f | n | P _e | I | LpA _{in} | LwA _{in} | q _v | p _{fs} | q _v | p _{fs} |
|---|-----|----|-------------------|----------------|------|-------------------|-------------------|----------------|-----------------|----------------|-----------------|
| | V | Hz | min ⁻¹ | W | A | dB(A) | dB(A) | m³/h | Pa | cfm | inH2O |
| 1 | 230 | 60 | 1670 | 43 | 0.19 | 53 | 60 | 1090 | 0 | 640 | 0.00 |
| 2 | 230 | 60 | 1645 | 45 | 0.20 | 53 | 60 | 985 | 20 | 580 | 0.08 |
| 3 | 230 | 60 | 1630 | 45 | 0.20 | 53 | 60 | 860 | 40 | 505 | 0.16 |
| 4 | 230 | 60 | 1610 | 48 | 0.22 | 54 | 62 | 725 | 54 | 425 | 0.22 |

U = Power supply · f = Frequency · n = Speed (rpm) · P_e = Power consumption · I = Current draw · LpA_{in} = Sound pressure level intake side · LwA_{in} = Sound power level intake side
 q_v = Air flow · p_{fs} = Pressure increase

