

AC axial fan - HyBlade

sickle-shaped blades (S series)

with guard grille for full nozzle

S4D630-CH01-01 ebmpapst Datasheet

sales@fansco.com

www.fansco.com

Limited partnership · Headquarters Muldingen

Amtsgericht (court of registration) Stuttgart · HRA 590344

General partner Elektrobau Muldingen GmbH · Headquarters Muldingen

Amtsgericht (court of registration) Stuttgart · HRB 590142



Nominal data

Type	S4D630-CH01-01		
Motor	M4D138-HF		
Phase		3~	3~
Nominal voltage	VAC	400	400
Wiring		Δ	Y
Frequency	Hz	50	50
Method of obtaining data		ml	ml
Valid for approval/standard		CE	CE
Speed	min ⁻¹	1310	1000
Power consumption	W	1970	1290
Current draw	A	3.4	2.1
Max. back pressure	Pa	200	115
Min. ambient temperature	°C	-40	-40
Max. ambient temperature	°C	60	60
Starting current	A	14	4.5

ml = Max. load · me = Max. efficiency · fa = Free air · cs = Customer specification · ce = Customer equipment
Subject to change

Data according to ErP Directive

		Actual	Req. 2015			
01 Overall efficiency η_{es}	%	35.4	35.4	09 Power consumption P_e	kW	1.89
02 Measurement category		A		09 Air flow q_v	m ³ /h	12645
03 Efficiency category		Static		09 Pressure increase p_{fs}	Pa	188
04 Efficiency grade N		40	40	10 Speed n	min ⁻¹	1335
05 Variable speed drive		No		11 Specific ratio*		1.00

Data obtained at optimum efficiency level.

The ErP data is determined using a motor-impeller combination in a standardized measurement setup.

* Specific ratio = $1 + p_g / 100\,000\text{ Pa}$

LU-124971



AC axial fan - HyBlade

sickle-shaped blades (S series)

with guard grille for full nozzle

Technical description

Weight	25 kg
Fan size	630 mm
Rotor surface	Cast in aluminum
Terminal box material	PP plastic
Blade material	Sheet aluminum insert, sprayed with PP plastic
Guard grille material	Steel, coated with black plastic (RAL 9005)
Number of blades	5
Blade pitch	-5°
Airflow direction	"V"
Direction of rotation	Clockwise, viewed toward rotor
Degree of protection	IP54
Insulation class	"F"
Moisture (F) / Environmental (H) protection class	H2
Max. permitted ambient temp. for motor (transport/storage)	+ 80 °C
Min. permitted ambient temp. for motor (transport/storage)	- 40 °C
Installation position	Any
Condensation drainage holes	On rotor and stator sides
Mode	S1
Motor bearing	Ball bearing
Touch current according to IEC 60990 (measuring circuit Fig. 4, TN system)	<= 3.5 mA
Electrical hookup	Via terminal box
Motor protection	Thermal overload protector (TOP) with basic insulation
With cable	Axial
Protection class	I (with customer connection of protective earth)
Conformity with standards	EN 60034-1 (2010); EN 61800-5-1; CE
Approval	EAC; VDE



AC axial fan - HyBlade

sickle-shaped blades (S series)

with guard grille for full nozzle

Product drawing

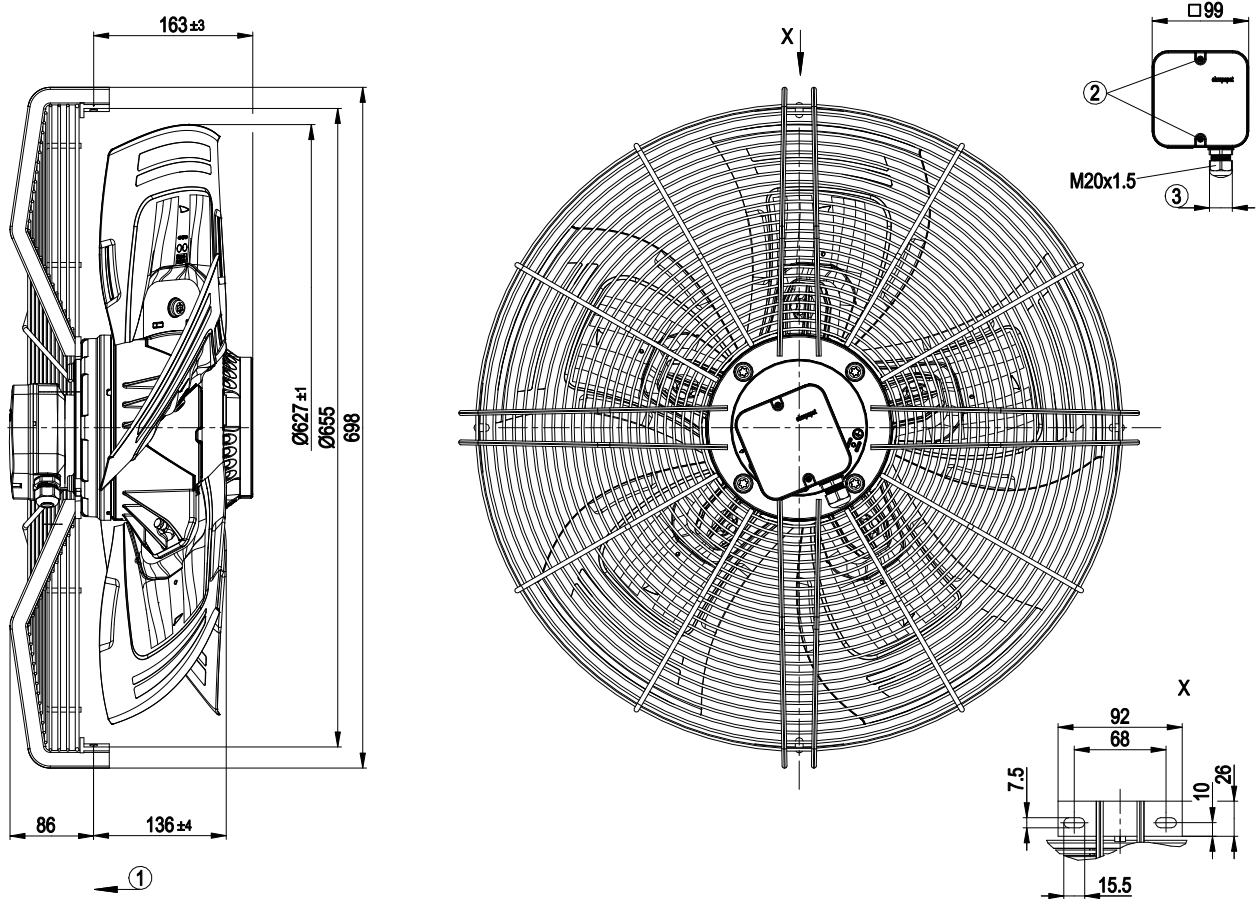

1	Direction of air flow "V"
2	Tightening torque 1.5 ± 0.2 Nm
3	Cable diameter min. 7 mm, max. 14 mm, tightening torque 2 ± 0.3 Nm



AC axial fan - HyBlade

sickle-shaped blades (S series)

with guard grille for full nozzle

Connection diagram

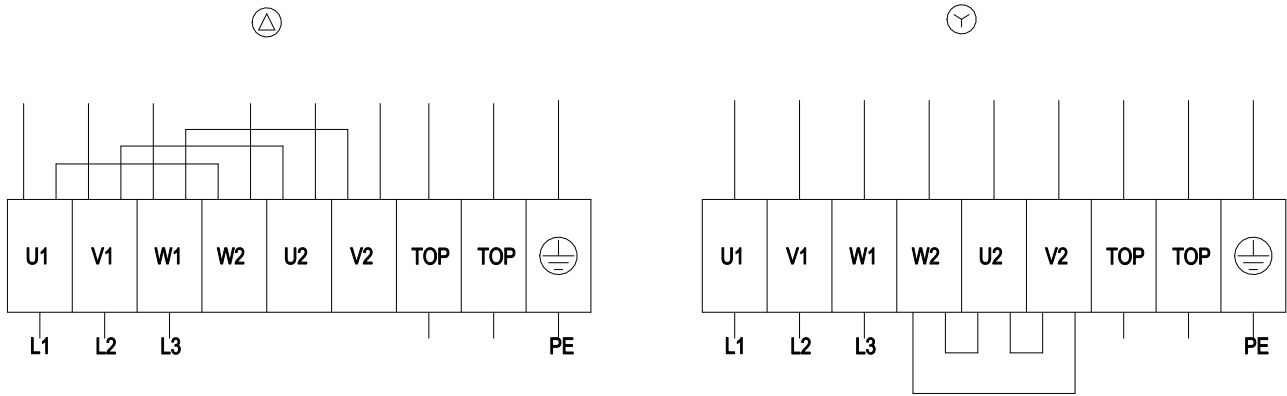

Δ	Delta connection	Y	Star connection	L1	= U1 = black
L2	= V1 = blue	L3	= W1 = brown	W2	yellow
U2	green	V2	white	TOP	2x gray
PE	green/yellow				



AC axial fan - HyBlade

sickle-shaped blades (S series)

with guard grille for full nozzle

Curves: Air performance 50 Hz

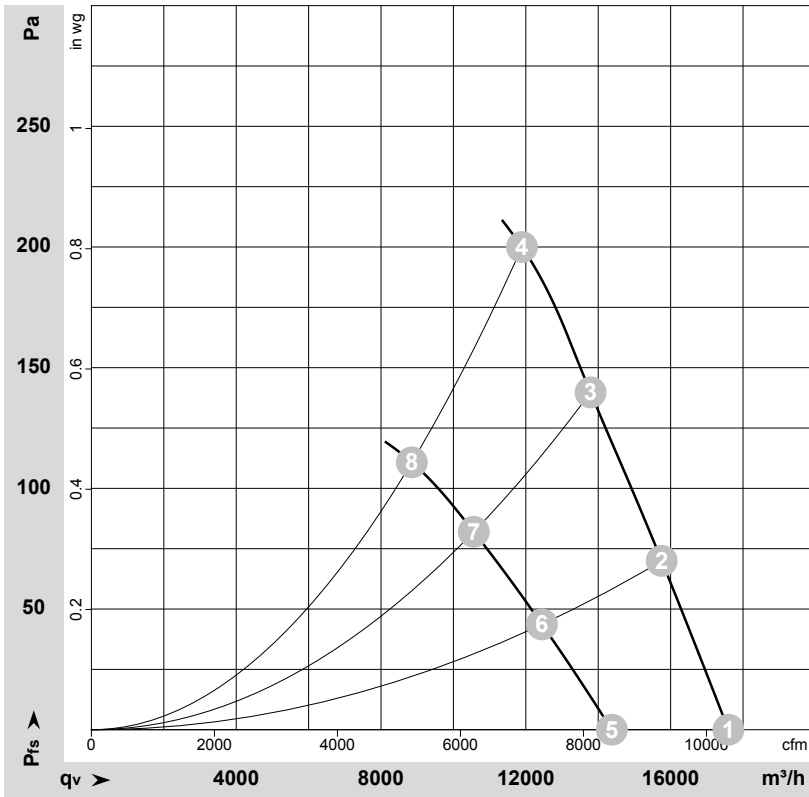

$\rho = 1.15 \text{ kg/m}^3 \pm 2 \%$

Measurement: LU-134384-1
Measurement: LU-109489-1

Air performance measured according to ISO 5801 installation category A. For detailed information on the measurement setup, contact ebm-papst. Intake sound level: Sound power level according to ISO 13347 / sound pressure level measured at 1 m distance from fan axis. The values given are valid under the specified measuring conditions and may vary due to conditions of installation. For deviations from the standard configuration, the parameters have to be checked on the installed unit.

Measured values

	Wired	U	f	n	P _e	I	LpA _{in}	LwA _{in}	LwA _{out}	qv	p _{fs}
		V	Hz	min ⁻¹	W	A	dB(A)	dB(A)	dB(A)	m ³ /h	Pa
1	Δ	400	50	1380	1483	2.83	70	77	77	17595	0
2	Δ	400	50	1360	1676	3.07	69	76	76	15755	70
3	Δ	400	50	1335	1854	3.33	69	75	75	13790	140
4	Δ	400	50	1310	1970	3.40	71	78	77	11890	200
5	Y	400	50	1125	1079	1.80	65	72	72	14375	0
6	Y	400	50	1075	1175	1.96	63	70	70	12445	44
7	Y	400	50	1035	1237	2.08	62	68	69	10560	82
8	Y	400	50	1000	1290	2.10	63	70	70	8850	111

Wired = Wiring · U = Power supply · f = Frequency · n = Speed · P_e = Power consumption · I = Current draw · LpA_{in} = Sound pressure level intake side · LwA_{in} = Sound power level intake side
LwA_{out} = Sound power level outlet side · qv = Air flow · p_{fs} = Pressure increase

