

AC axial fan - HyBlade

sickle-shaped blades (S series)

with guard grille for full nozzle

S4D630-BR11-07 ebmpapst Datasheet

sales@fansco.com

www.fansco.com

Limited partnership · Headquarters Mulfingen

Amtsgericht (court of registration) Stuttgart · HRA 590344

General partner Elektrobau Mulfingen GmbH · Headquarters Mulfingen

Amtsgericht (court of registration) Stuttgart · HRB 590142

Nominal data

Type	S4D630-BR11-07				
Motor	M4D110-IA				
Phase		3~	3~	3~	3~
Nominal voltage	VAC	400	400	480	480
Wiring		Δ	Y	Δ	Y
Frequency	Hz	60	60	60	60
Method of obtaining data		ml	ml	ml	ml
Valid for approval/standard		CE	CE	CE	CE
Speed (rpm)	min ⁻¹	1310	835	1440	960
Power consumption	W	1320	600	1590	820
Current draw	A	2.32	1.1	2.4	1.22
Max. back pressure	Pa	90	37	110	50
Max. back pressure	inH ₂ O	0.36	0.15	0.44	0.2
Min. ambient temperature	°C	-40	-40	-40	-40
Max. ambient temperature	°C	40	40	40	40
Starting current	A	4.8	1.5	6.1	2.0

ml = Max. load · me = Max. efficiency · fa = Free air · cs = Customer specification · ce = Customer equipment
Subject to change

Data according to Commission Regulation (EU) 327/2011

	Actual	Req. 2015				
01 Overall efficiency η_{es}	%	34.1	34	09 Power consumption P_e	kW	1.14
02 Measurement category		A		09 Air flow q_v	m ³ /h	8070
03 Efficiency category		Static		09 Pressure increase p_{fs}	Pa	175
04 Efficiency grade N		40.1	40	10 Speed (rpm) n	min ⁻¹	1200
05 Variable speed drive		No		11 Specific ratio*		1.00

Data obtained at optimum efficiency level.
The ErP data is determined using a motor-impeller combination in a standardized measurement setup.

* Specific ratio = $1 + p_{fs} / 100\,000\text{ Pa}$

LU-127547



AC axial fan - HyBlade

sickle-shaped blades (S series)

with guard grille for full nozzle

Technical description

Weight	16.5 kg
Fan size	630 mm
Rotor surface	Cast in aluminum
Terminal box material	PP plastic
Blade material	Sheet aluminum insert, sprayed with PP plastic
Guard grille material	Steel, coated with black plastic (RAL 9005)
Number of blades	5
Blade pitch	-10°
Airflow direction	"A"
Direction of rotation	Clockwise, viewed toward rotor
Degree of protection	IP54
Insulation class	"F"
Moisture (F) / Environmental (H) protection class	F3-1
Max. permitted ambient temp. for motor (transport/storage)	+ 80 °C
Min. permitted ambient temp. for motor (transport/storage)	- 40 °C
Installation position	Shaft horizontal or rotor on bottom; rotor on top on request
Condensation drainage holes	On rotor side
Mode	S1
Motor bearing	Ball bearing
Touch current according to IEC 60990 (measuring circuit Fig. 4, TN system)	<= 3.5 mA
Electrical hookup	Via terminal box
Motor protection	Thermal overload protector (TOP) with basic insulation
With cable	Axial
Protection class	I (with customer connection of protective earth)
Conformity with standards	EN 61800-5-1; CE
Approval	VDE



AC axial fan - HyBlade

sickle-shaped blades (S series)

with guard grille for full nozzle

Product drawing

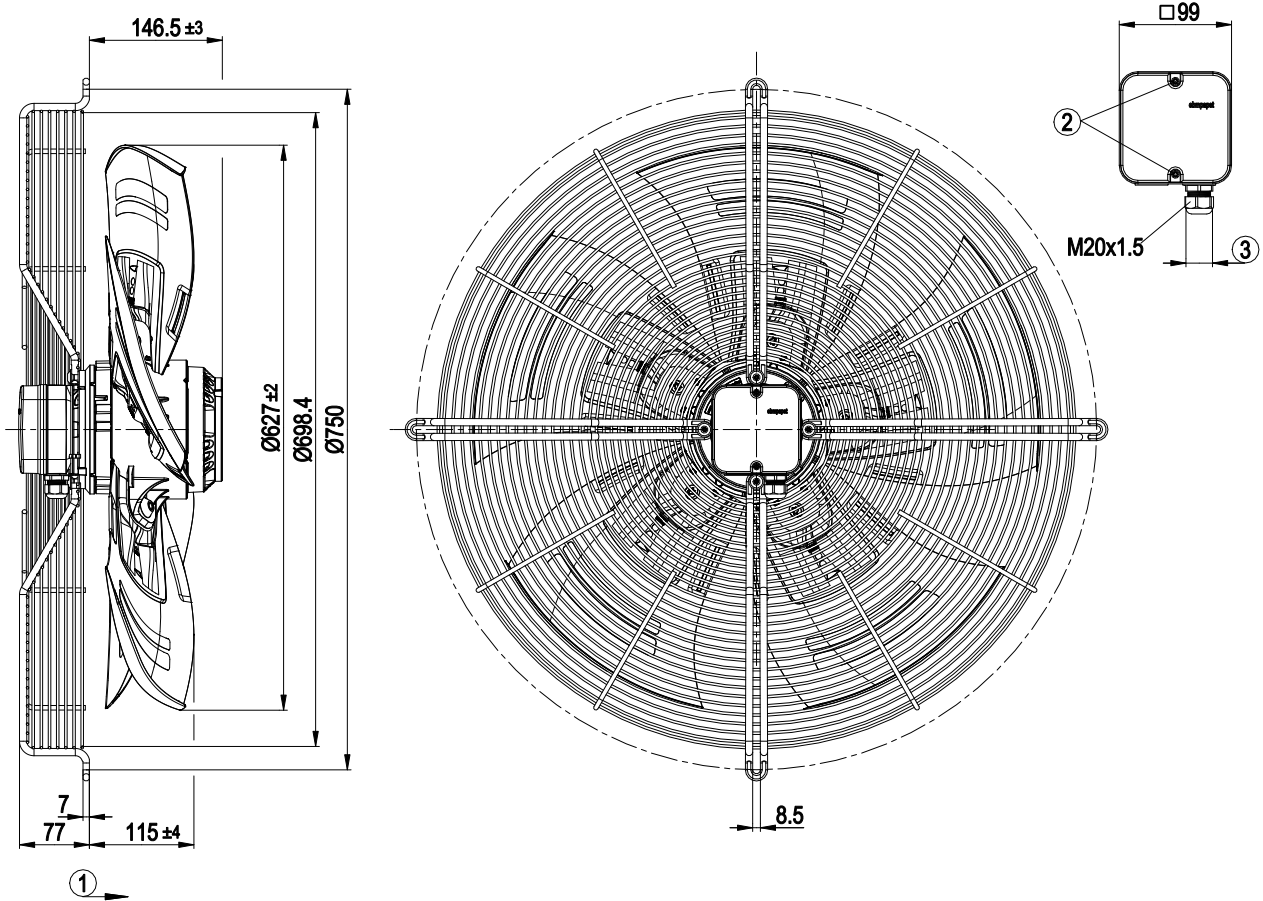

1	Direction of air flow "A"
2	Tightening torque 1.5 ± 0.2 Nm
3	Cable diameter: min. 6 mm, max. 12 mm; tightening torque 2 ± 0.3 Nm



AC axial fan - HyBlade

sickle-shaped blades (S series)

with guard grille for full nozzle

Connection diagram



Δ	Delta connection	Y	Star connection	L1	= U1 = black
L2	= V1 = blue	L3	= W1 = brown	W2	yellow
U2	green	V2	white	TOP	2x gray
PE	green/yellow				



AC axial fan - HyBlade

sickle-shaped blades (S series)

with guard grille for full nozzle

Curves: Air performance 60 Hz

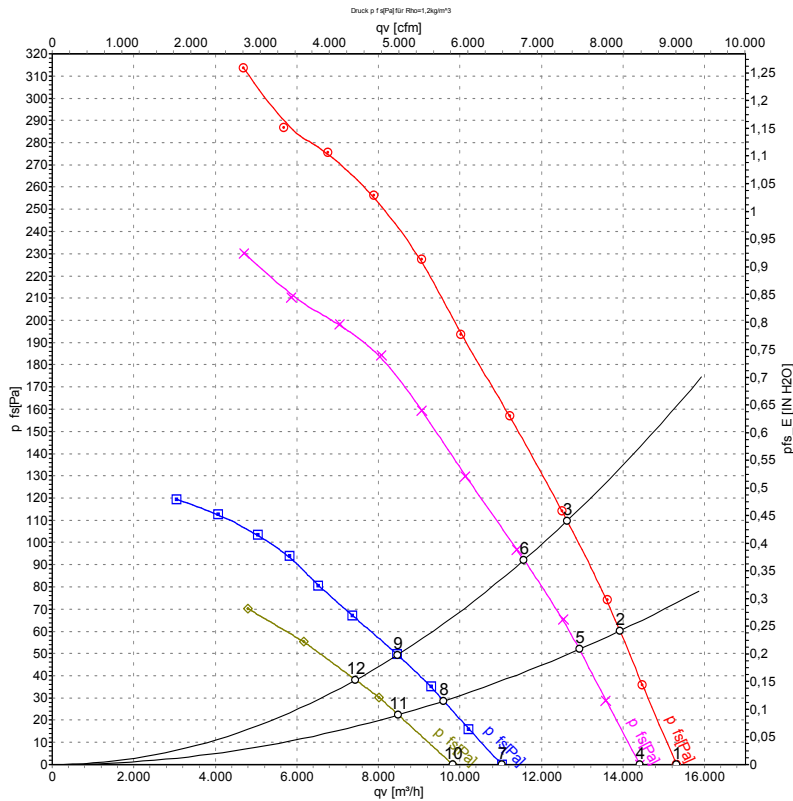

Measurement: LU-137181-1
 Measurement: LU-127706-1
 Measurement: LU-137186-1
 Measurement: LU-127783-1

Air performance measured according to ISO 5801 installation category A. For detailed information on the measurement setup, contact ebmpapst. Intake sound level: Sound power level according to ISO 13347 / sound pressure level measured at 1 m distance from fan axis. The values given are valid under the specified measuring conditions and may vary due to conditions of installation. For deviations from the standard configuration, the parameters have to be checked on the installed unit.

Measured values

	Wired	U	f	n	P _e	I	LpA _{in}	LwA _{in}	LwA _{out}	q _v	P _{fs}	q _v	P _{fs}
		V	Hz	min ⁻¹	W	A	dB(A)	dB(A)	dB(A)	m ³ /h	Pa	cfm	inH2O
1	Δ	480	60	1540	1291	2.02	74	81	81	15310	0	9010	0.00
2	Δ	480	60	1490	1446	2.21	71	79	78	13920	60	8195	0.24
3	Δ	480	60	1440	1590	2.40	69	76	76	12620	110	7430	0.44
4	Δ	400	60	1440	1120	2.00	72	79	78	14410	0	8480	0.00
5	Δ	400	60	1370	1227	2.17	69	76	75	12930	52	7610	0.21
6	Δ	400	60	1310	1320	2.32	66	74	73	11570	92	6810	0.37
7	Y	480	60	1095	757	1.11	67	73	72	11030	0	6490	0.00
8	Y	480	60	1025	791	1.17	63	70	69	9605	29	5650	0.12
9	Y	480	60	960	820	1.22	60	67	67	8470	50	4985	0.20
10	Y	400	60	970	578	1.06	63	70	69	9820	0	5780	0.00
11	Y	400	60	895	590	1.09	60	67	66	8485	22	4995	0.09
12	Y	400	60	835	600	1.10	58	65	65	7440	38	4380	0.15

Wired = Wiring · U = Power supply · f = Frequency · n = Speed (rpm) · P_e = Power consumption · I = Current draw · LpA_{in} = Sound pressure level intake side · LwA_{in} = Sound power level intake side · LwA_{out} = Sound power level outlet side · q_v = Air flow · P_{fs} = Pressure increase

