

AC axial fan - HyBlade

sickle-shaped blades (S series)

with guard grille for full nozzle

S4D560-CO01-03 ebmpapst Datasheet

sales@fansco.com

www.fansco.com

Limited partnership · Headquarters Mulfingen

Amtsgericht (court of registration) Stuttgart · HRA 590344

General partner Elektrobau Mulfingen GmbH · Headquarters Mulfingen

Amtsgericht (court of registration) Stuttgart · HRB 590142

Nominal data

Type	S4D560-CO01-03						
Motor	M4D110-GF						
Phase		3~	3~	3~	3~	3~	3~
Nominal voltage	VAC	230	230	277	400	400	480
Wiring		Δ	Δ	Δ	Y	Y	Y
Frequency	Hz	50	60	60	50	60	60
Method of obtaining data		ml	ml	ml	ml	ml	ml
Valid for approval/standard		CE	CE	CE	CE	CE	CE
Speed (rpm)	min ⁻¹	1330	1500	1580	1330	1500	1580
Power consumption	W	800	1050	1170	800	1050	1170
Current draw	A	2.72	3.12	3.17	1.57	1.8	1.83
Max. back pressure	Pa	155	120	130	155	120	130
Max. back pressure	inH ₂ O	0.62	0.48	0.52	0.62	0.48	0.52
Min. ambient temperature	°C	-40	-40	-40	-40	-40	-40
Max. ambient temperature	°C	65	60	60	65	60	60
Starting current	A	10.6	9.7	12.1	6.1	5.6	7.0

ml = Max. load · me = Max. efficiency · fa = Free air · cs = Customer specification · ce = Customer equipment
Subject to change

Data according to ErP Directive

	Actual	Req. 2015				
01 Overall efficiency η_{es}	%	35.1	33	09 Power consumption P_e	kW	0.79
02 Measurement category	A			09 Air flow q_v	m ³ /h	6435
03 Efficiency category	Static			09 Pressure increase p_{fs}	Pa	157
04 Efficiency grade N	42.1	40		10 Speed (rpm) n	min ⁻¹	1330
05 Variable speed drive	No			11 Specific ratio*		1.00

Data obtained at optimum efficiency level.
The ErP data is determined using a motor-impeller combination in a standardized measurement setup.

* Specific ratio = $1 + p_{fs} / 100\,000\text{ Pa}$

LU-110514



AC axial fan - HyBlade

sickle-shaped blades (S series)

with guard grille for full nozzle

Technical description

Weight	13.5 kg
Fan size	560 mm
Rotor surface	Cast in aluminum
Terminal box material	PP plastic
Blade material	Sheet aluminum insert, sprayed with PP plastic
Guard grille material	Steel, coated with black plastic (RAL 9005)
Number of blades	5
Blade pitch	-10°
Airflow direction	"V"
Direction of rotation	Counterclockwise, viewed toward rotor
Degree of protection	IP54
Insulation class	"F"
Moisture (F) / Environmental (H) protection class	H2
Max. permitted ambient temp. for motor (transport/storage)	+80 °C
Min. permitted ambient temp. for motor (transport/storage)	-40 °C
Installation position	Shaft horizontal or rotor on bottom; rotor on top on request
Condensation drainage holes	On rotor side
Mode	S1
Motor bearing	Ball bearing
Touch current according to IEC 60990 (measuring circuit Fig. 4, TN system)	<= 3.5 mA
Electrical hookup	Via terminal box
Motor protection	Thermal overload protector (TOP) with basic insulation
With cable	Axial
Protection class	I (with customer connection of protective earth)
Conformity with standards	EN 61800-5-1; CE
Approval	VDE; UL 1004-1; EAC; CSA C22.2 No. 100; CCC



AC axial fan - HyBlade

sickle-shaped blades (S series)

with guard grille for full nozzle

Product drawing

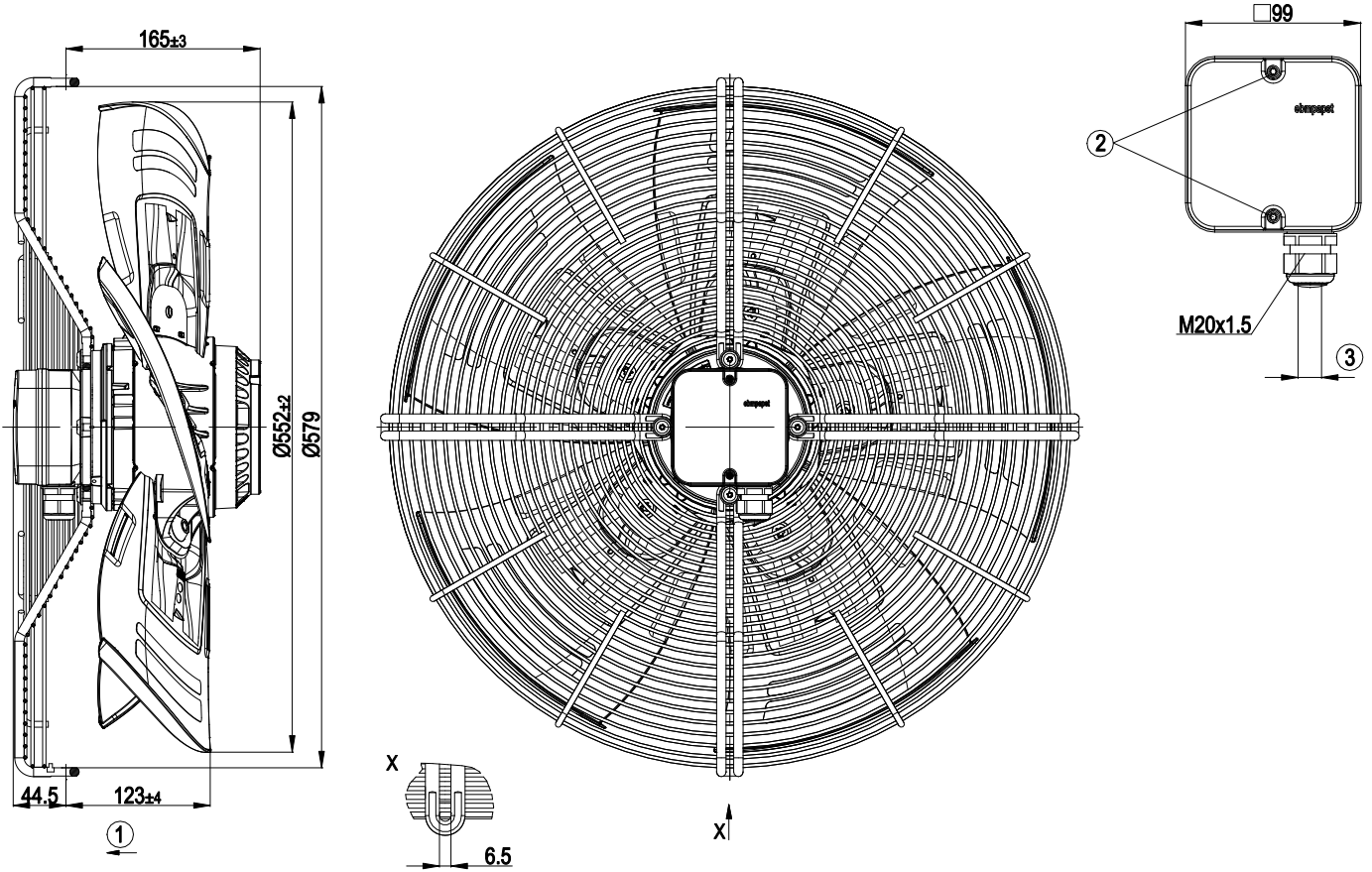

1	Direction of air flow "V"
2	Tightening torque 1.5 ± 0.2 Nm
3	Cable diameter min. 6 mm, max. 12 mm, tightening torque 2 ± 0.3 Nm



AC axial fan - HyBlade

sickle-shaped blades (S series)

with guard grille for full nozzle

Connection diagram

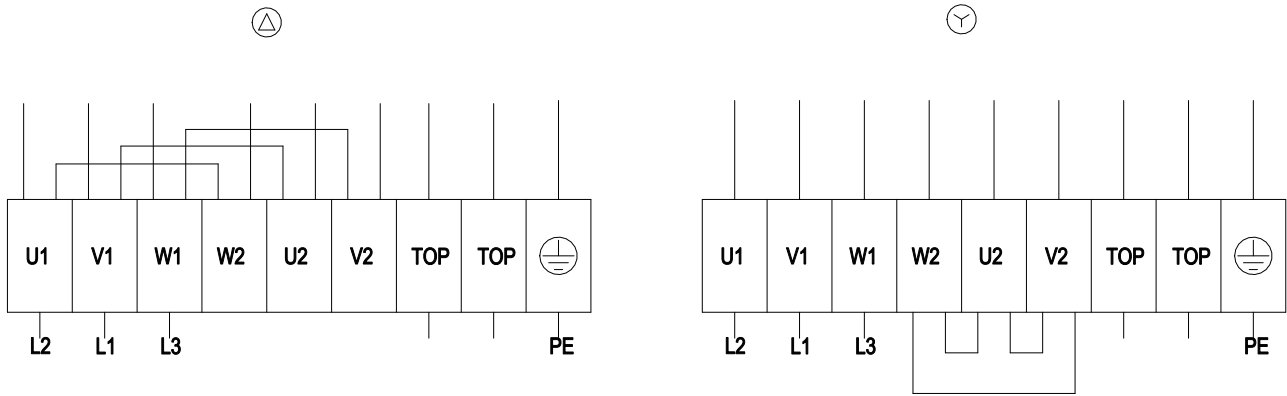

Δ	Delta connection	Y	Star connection	L1	= V1 = blue
L2	= U1 = black	L3	= W1 = brown	W2	yellow
U2	green	V2	white	TOP	2x gray
PE	green/yellow				



AC axial fan - HyBlade

sickle-shaped blades (S series)

with guard grille for full nozzle

Curves: Air performance 50 Hz

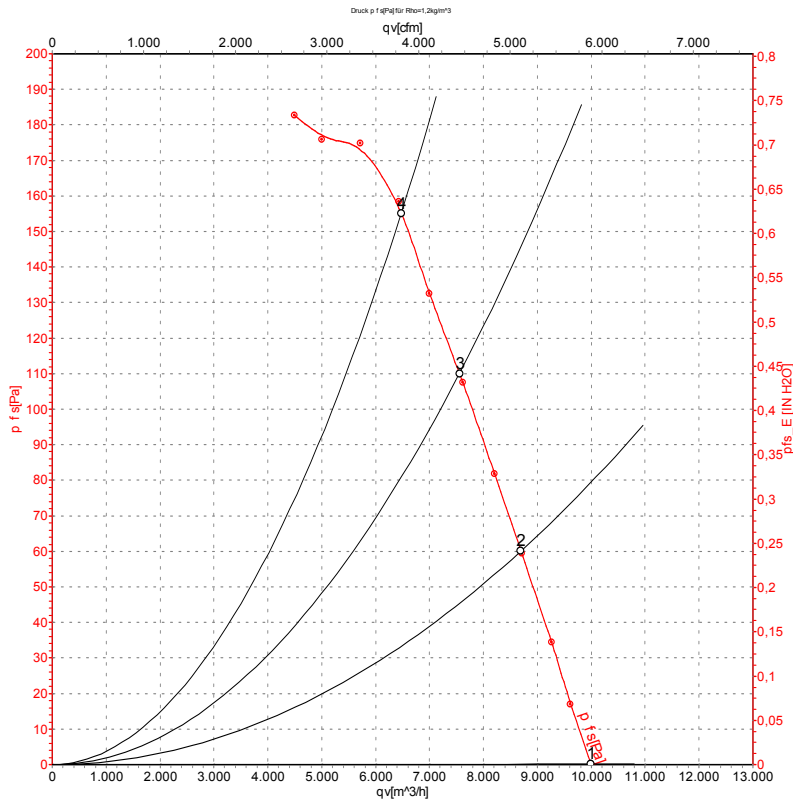

Measurement: LU-110514-1

Air performance measured according to ISO 5801 installation category A. For detailed information on the measurement setup, contact ebm-papst. Intake sound level: Sound power level according to ISO 13347 / sound pressure level measured at 1 m distance from fan axis. The values given are valid under the specified measuring conditions and may vary due to conditions of installation. For deviations from the standard configuration, the parameters have to be checked on the installed unit.

Measured values

	Wired	U	f	n	Pe	I	LpA _{in}	LwA _{in}	LwA _{out}	qv	p _{fs}	qv	p _{fs}
		V	Hz	min ⁻¹	W	A	dB(A)	dB(A)	dB(A)	m ³ /h	Pa	cfm	inH ₂ O
1	Y	400	50	1395	545	1.22	71	77	77	9995	0	5885	0.00
2	Y	400	50	1370	657	1.34	67	73	73	8695	60	5120	0.24
3	Y	400	50	1350	743	1.43	69	75	74	7555	110	4445	0.44
4	Y	400	50	1330	800	1.57	69	75	75	6475	155	3810	0.62

Wired = Wiring · U = Power supply · f = Frequency · n = Speed (rpm) · Pe = Power consumption · I = Current draw · LpA_{in} = Sound pressure level intake side · LwA_{in} = Sound power level intake side
 LwA_{out} = Sound power level outlet side · qv = Air flow · p_{fs} = Pressure increase



AC axial fan - HyBlade

sickle-shaped blades (S series)

with guard grille for full nozzle

Curves: Air performance 60 Hz

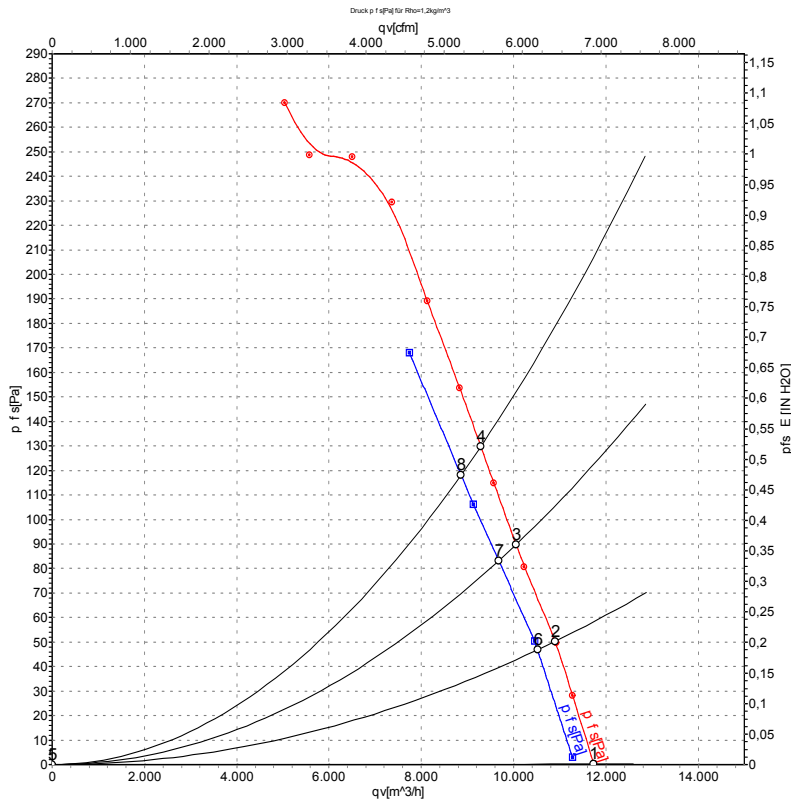

Measurement: LU-110519-1
Measurement: LU-110709-1

Air performance measured according to ISO 5801 installation category A. For detailed information on the measurement setup, contact ebm-papst. Intake sound level: Sound power level according to ISO 13347 / sound pressure level measured at 1 m distance from fan axis. The values given are valid under the specified measuring conditions and may vary due to conditions of installation. For deviations from the standard configuration, the parameters have to be checked on the installed unit.

Measured values

	Wired	U	f	n	P _e	I	LpA _{in}	LwA _{in}	LwA _{out}	η _{es}	q _v	P _{fs}	q _v	P _{fs}
		V	Hz	min ⁻¹	W	A	dB(A)	dB(A)	dB(A)	%	m ³ /h	Pa	cfm	inH ₂ O
1	Y	480	60	1650	883	1.41	75	81	81	44	11740	0	6910	0.00
2	Y	480	60	1625	984	1.53	71	78	78	46	10900	50	6415	0.20
3	Y	480	60	1605	1072	1.62	71	77	77	45	10050	90	5915	0.36
4	Y	480	60	1580	1170	1.83	72	78	77	44	9290	130	5465	0.52
5	Y	400	60	1585	825	1.50	73.5	79.5	79.5	43	11280	0	6640	0.00
6	Y	400	60	1555	905	1.54	70	77	77	45	10520	47	6190	0.19
7	Y	400	60	1525	979	1.65	70	76	76	44	9675	83	5695	0.33
8	Y	400	60	1500	1050	1.80	71	77	76	42	8860	120	5215	0.48

Wired = Wiring · U = Power supply · f = Frequency · n = Speed (rpm) · P_e = Power consumption · I = Current draw · LpA_{in} = Sound pressure level intake side · LwA_{in} = Sound power level intake side
LwA_{out} = Sound power level outlet side · η_{es} = Total efficiency of fan · q_v = Air flow · P_{fs} = Pressure increase

