

ebm-papst ventilator (Shanghai)Co.,Ltd.

No.418, Hua jing Road, Wai Gao qiao Free Trade Zone, Pudong

S4D560-CN03-01/F01 ebmpapst Datasheet

sales@fansco.com

www.fansco.com

## Nominal data

Type	S4D560-CN03-01/F01				
Motor	M4D110-GF				
Phase		3~	3~	3~	3~
Nominal voltage	VAC	400	400	400	400
Connection		Δ	Y	Δ	Y
Frequency	Hz	50	50	60	60
Type of data definition		ml	ml	ml	ml
Valid for approval / standard		-	-	-	-
Speed	min <sup>-1</sup>	1270	940	1400	910
Power input	W	1020	620	1290	640
Current draw	A	1.76	1.05	2.30	1.20
Max. back pressure	Pa	160	90	90	40
Min. ambient temperature	°C	-40	-40	-40	-40
Max. ambient temperature	°C	60	60	40	40
Starting current	A	6.5	2.1	5.9	1.9

ml = Max. load · me = Max. efficiency · fa = Running at free air · cs = Customer specs · cu = Customer unit  
Subject to alterations



## Technical features

Mass	13.3 kg
Size	560 mm
Surface of rotor	Cast in aluminium
Material of terminal box	PP plastic
Material of blades	Aluminium sheet insert, sprayed with PP plastic
Number of blades	5
Blade angle	-5°
Direction of air flow	"V"
Direction of rotation	Counter-clockwise, seen on rotor
Type of protection	IP 54
Insulation class	"F"
Humidity class	F3-1
Max. permissible ambient motor temp. (transp./ storage)	+ 80 °C
Min. permissible ambient motor temp. (transp./storage)	- 40 °C
Mounting position	Shaft horizontal or rotor on bottom; rotor on top on request
Condensate discharge holes	Rotor-side
Operation mode	S1
Motor bearing	Ball bearing
Touch current acc. IEC 60990 (measuring network Fig. 4, TN system)	<= 3.5 mA
Electrical leads	Via terminal box
Motor protection	Thermal overload protector (TOP) brought out
Cable exit	Axial
Protection class	I (if protective earth is connected by customer)
Product conforming to standard	EN 61800-5-1
Approval	CCC; EAC;

Product drawing

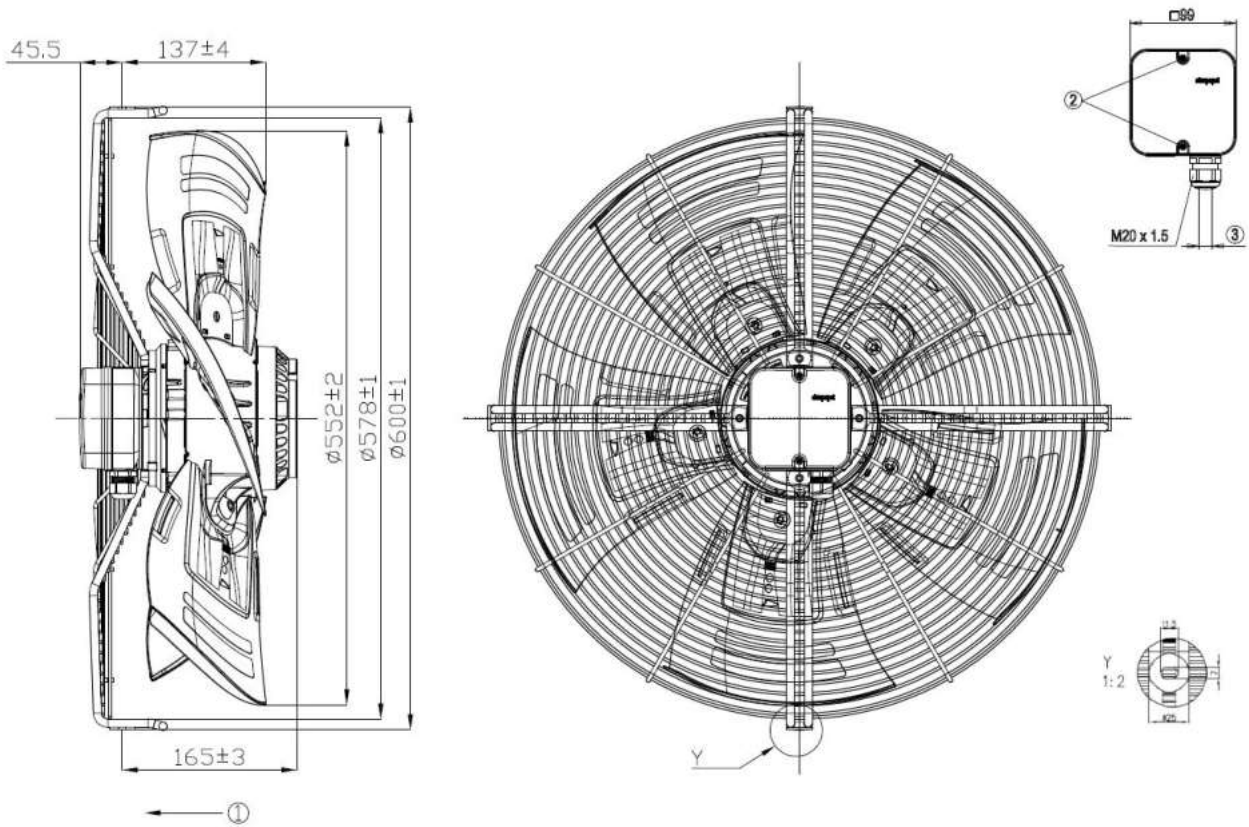

1	Direction of air flow "V"
2	Tightening torque $1.5 \pm 0.2$ Nm
3	Cable diameter: min. 6 mm, max. 12 mm, tightening torque: $2 \pm 0.3$ Nm



## Connection screen

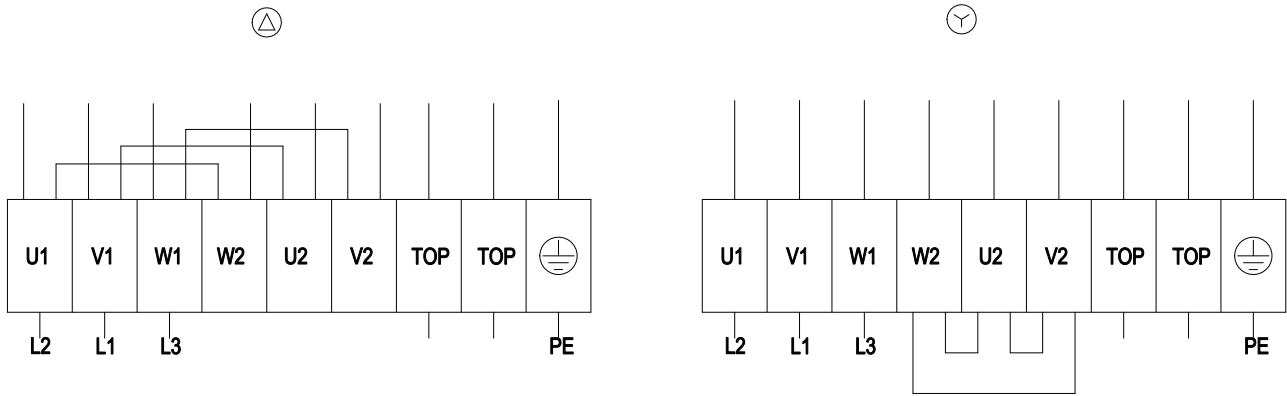

Δ	Delta connection	Y	Star connection	L1	= V1 = blue
L2	= U1 = black	L3	= W1 = brown	W2	yellow
U2	green	V2	white	TOP	2 x grey
PE	green/yellow				

## Charts: Air flow 50 Hz

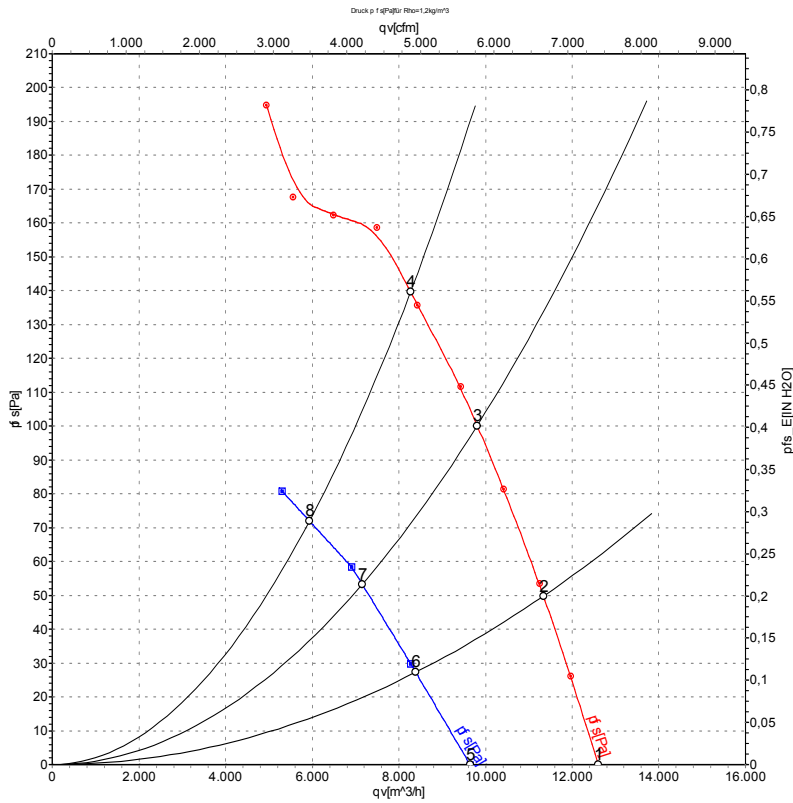

Air performance measured as per ISO 5801 Installation category A. For detailed information on the measuring set-up, please contact ebmpapst. Suction-side noise levels: LwA measured as per ISO 13347 / LpA measured with 1m distance to fan axis. The values given are valid under the measuring conditions mentioned above and may vary according to the actual installation situation. With any deviation from the standard set-up, the specific values have to be checked and reviewed with the unit installed.

## Measured values

	Conn.	U	f	n	P <sub>e</sub>	I	LpA <sub>in</sub>	LwA <sub>in</sub>	LwA <sub>out</sub>	qv	p <sub>fs</sub>
		V	Hz	min <sup>-1</sup>	W	A	dB(A)	dB(A)	dB(A)	m <sup>3</sup> /h	Pa
1	Δ	400	50	1295	961	1.69	67	74	75	12600	0
2	Δ	400	50	1270	1025	1.78	66	73	74	11340	50
3	Δ	400	50	1250	1092	1.87	65	72	73	9810	100
4	Δ	400	50	1220	1160	1.95	70	77	76	8270	140
5	Y	400	50	990	604	1.01	61	67	68	9640	0
6	Y	400	50	930	616	1.03	59	65	66	8390	27
7	Y	400	50	900	635	1.06	59	65	66	7155	53
8	Y	400	50	870	650	1.10	61	67	67	5935	72

Conn. = Connection · U = Supply voltage · f = Frequency · n = Speed · P<sub>e</sub> = Power input · I = Current draw · LpA<sub>in</sub> = Sound pressure level inlet side · LwA<sub>in</sub> = Sound power level inlet side · LwA<sub>out</sub> = Sound power level outlet side · qv = Air flow · p<sub>fs</sub> = Pressure increase



## Charts: Air flow 60 Hz

Line	Idno	Type	Idx	U [V]	f [Hz]	C [mF]	Ust [V]	Layout	Inst. cat.	Remark
■	4989	A4D560AN0301	91B	400	60			Δ	A	Rho=1.2;
◆	4971	A4D560AN0301	01D	400	60			Y	A	Rho=1.2;

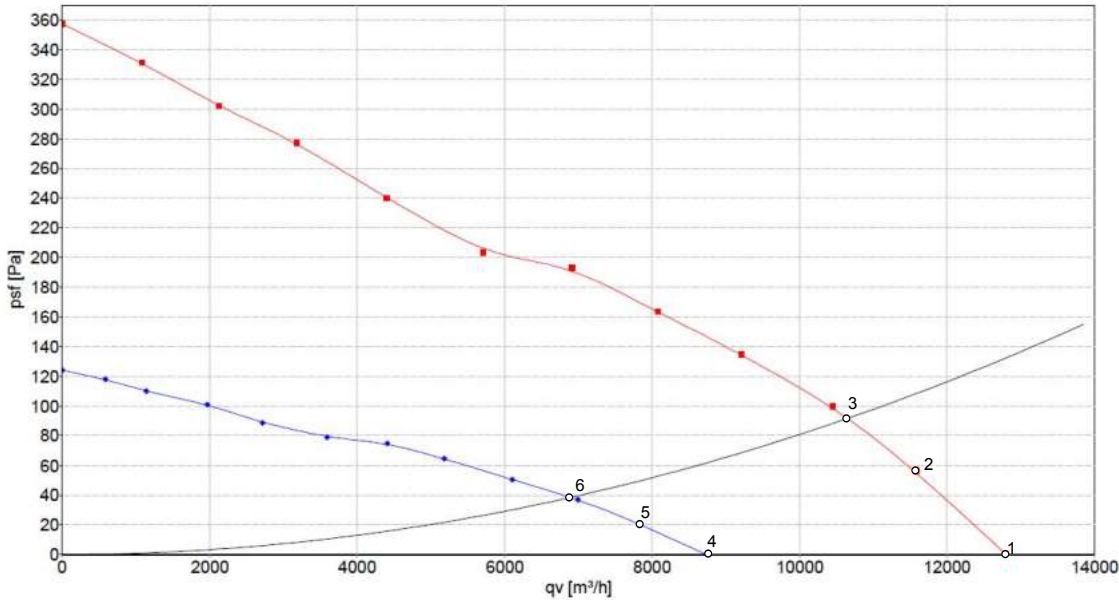

Air performance measured as per ISO 5801 Installation category A. For detailed information on the measuring set-up, please contact ebm-papst. Suction-side noise levels: LwA measured as per ISO 13347 / LpA measured with 1m distance to fan axis. The values given are valid under the measuring conditions mentioned above and may vary according to the actual installation situation. With any deviation from the standard set-up, the specific values have to be checked and reviewed with the unit installed.

## Measured values

	Conn.	U	f	n	P <sub>e</sub>	I	qv	P <sub>fs</sub>
		V	Hz	min <sup>-1</sup>	W	A	m <sup>3</sup> /h	Pa
1	Δ	400	60	1466	1124	1.92	12797	0
2	Δ	400	60	1424	1221	2.08	11582	56
3	Δ	400	60	1400	1290	2.30	10680	90
4	Y	400	60	995	613	1.08	8730	0
5	Y	400	60	954	627	1.11	7840	21
6	Y	400	60	910	640	1.20	6796	40

Conn. = Connection · U = Supply voltage · f = Frequency · n = Speed · P<sub>e</sub> = Power input · I = Current draw · LpA<sub>in</sub> = Sound pressure level inlet side · LwA<sub>in</sub> = Sound power level inlet side  
LwA<sub>out</sub> = Sound power level outlet side · qv = Air flow · p<sub>fs</sub> = Pressure increase