

S4D560-AQ01-01 ebmpapst Datasheet

sales@fansco.com

www.fansco.com

Limited partnership · Headquarters Mulfingen

Amtsgericht (court of registration) Stuttgart · HRA 590344

General partner Elektrobau Mulfingen GmbH · Headquarters Mulfingen

Amtsgericht (court of registration) Stuttgart · HRB 590142

Nominal data

Type	S4D560-AQ01-01				
Motor	M4D110-IA				
Phase		3~	3~	3~	3~
Nominal voltage	VAC	400	400	400	400
Wiring		Δ	Y	Δ	Y
Frequency	Hz	50	50	60	60
Method of obtaining data		ml	ml	ml	ml
Valid for approval/standard		CE	CE	CE	CE
Speed (rpm)	min ⁻¹	1350	1110	1540	1150
Power consumption	W	1100	760	1380	840
Current draw	A	2.32	1.3	2.4	1.45
Max. back pressure	Pa	170	115	90	50
Max. back pressure	in. wg	0.68	0.46	0.36	0.2
Min. ambient temperature	°C	-40	-40	-40	-40
Max. ambient temperature	°C	65	65	60	60
Starting current	A	10	3.35	9.5	3.2

ml = Max. load · me = Max. efficiency · fa = Free air · cs = Customer specification · ce = Customer equipment
Subject to change

Data according to Commission Regulation (EU) 327/2011 (prEN 17166)

	Actual	Req. 2015				
01 Overall efficiency η_{es}	%	35.2	33.8	09 Power consumption P_e	kW	1.05
02 Measurement category		A		09 Air flow q_v	m ³ /h	8985
03 Efficiency category		Static		09 Pressure increase p_{fs}	Pa	150
04 Efficiency grade N		41.4	40	10 Speed (rpm) n	min ⁻¹	1365
05 Variable speed drive		No		11 Specific ratio*		1.00

Data obtained at optimum efficiency level.

* Specific ratio = $1 + p_{fs} / 100\,000\text{ Pa}$

LU-200371

The efficiency values displayed for achieving conformity with the Ecodesign Regulation EU 327/2011 has been reached with defined air duct components (e.g. inlet rings).

The dimensions must be requested from ebm-papst. If other air conduction geometries are used on the installation side, the ebm-papst evaluation loses its validity/the conformity must be confirmed again.

The product does not fall within the scope of Regulation (EU) 2019/1781 due to the exception specified in Article 2 (2a) (motors completely integrated into a product).

AC axial panel fan - HyBlade

sickle-shaped blades (S series)

with guard grille for short nozzle

Technical description

Weight	16 kg
Size	560 mm
Motor size	110
Rotor surface	Cast in aluminum
Terminal box material	PP plastic
Blade material	Sheet aluminum insert, sprayed with PP plastic
Guard grille material	Steel, coated with black plastic (RAL 9005)
Number of blades	5
Blade pitch	-5°
Airflow direction	V
Direction of rotation	Counterclockwise, viewed toward rotor
Degree of protection	IP54
Insulation class	"F"
Moisture (F) / Environmental (H) protection class	H2
Ambient temperature note	Occasional start-up at temperatures between -40°C and -25°C is permitted. For continuous operation at ambient temperatures below -25°C (such as refrigeration applications), use must be made of a fan design with special low-temperature bearings.
Max. permitted ambient temp. for motor (transport/storage)	+80 °C
Min. permitted ambient temp. for motor (transport/storage)	-40 °C
Installation position	Shaft horizontal or rotor on bottom; rotor on top on request
Condensation drainage holes	On rotor side
Mode	S1
Motor bearing	Ball bearing
Touch current according to IEC 60990 (measuring circuit Fig. 4, TN system)	<= 3.5 mA
Electrical hookup	Terminal box
Motor protection	Thermal switch auto reset, lead out, with basic insulation
With cable	Axial
Protection class assignment	I; If a protective earth is connected by the customer This component for installation may have several local protection classes. This information relates to this component's basic design. The final protection class is based on the component's intended installation and connection.
Conformity with standards	EN 60034-1 (2010); CE
Approval	VDE; EAC

AC axial panel fan - HyBlade

sickle-shaped blades (S series)
with guard grille for short nozzle

Product drawing

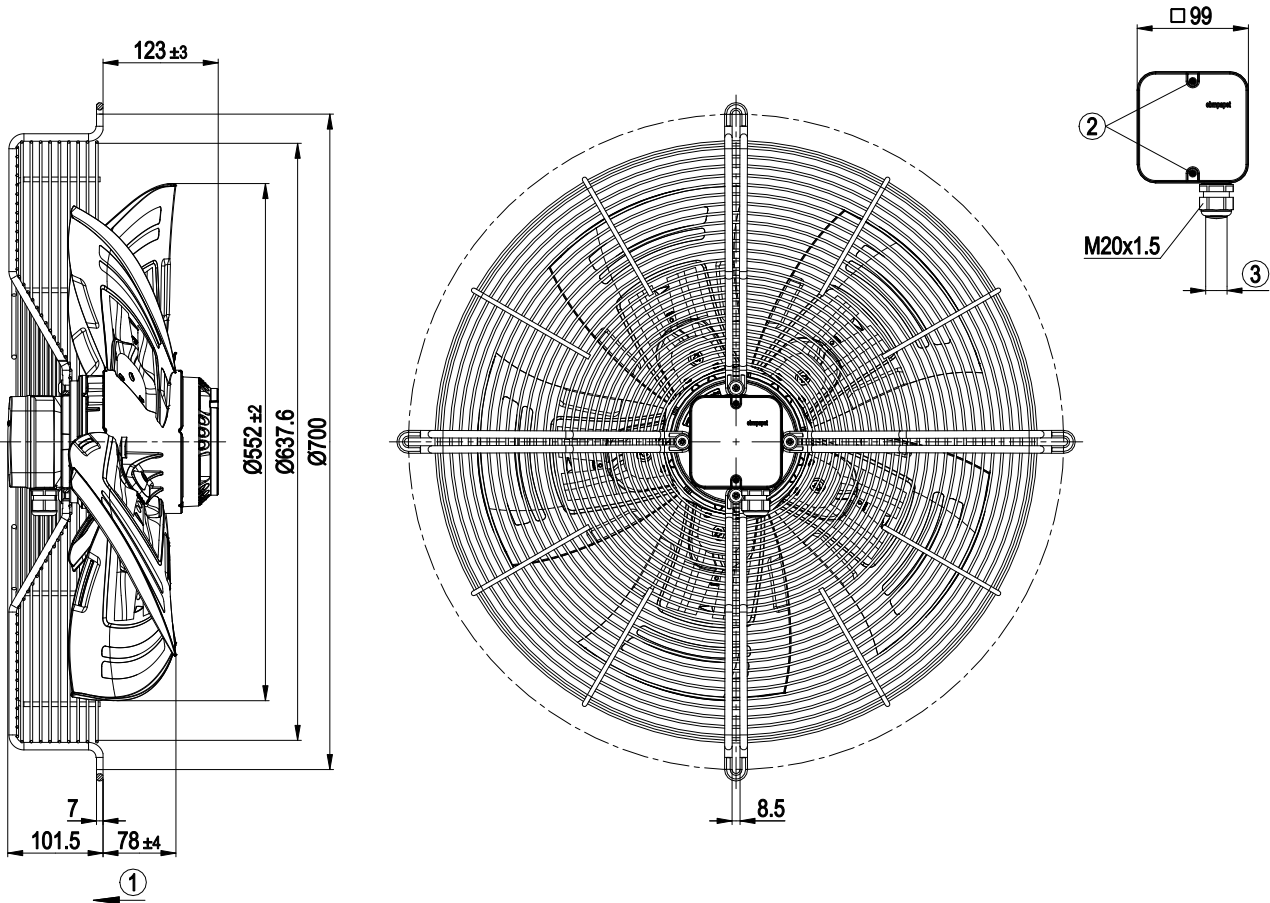

1	Direction of air flow "V"
2	Tightening torque 1.5 ± 0.2 Nm
3	Cable diameter min. 6 mm, max. 12 mm, tightening torque 2 ± 0.3 Nm

AC axial panel fan - HyBlade

sickle-shaped blades (S series)
with guard grille for short nozzle

Connection diagram

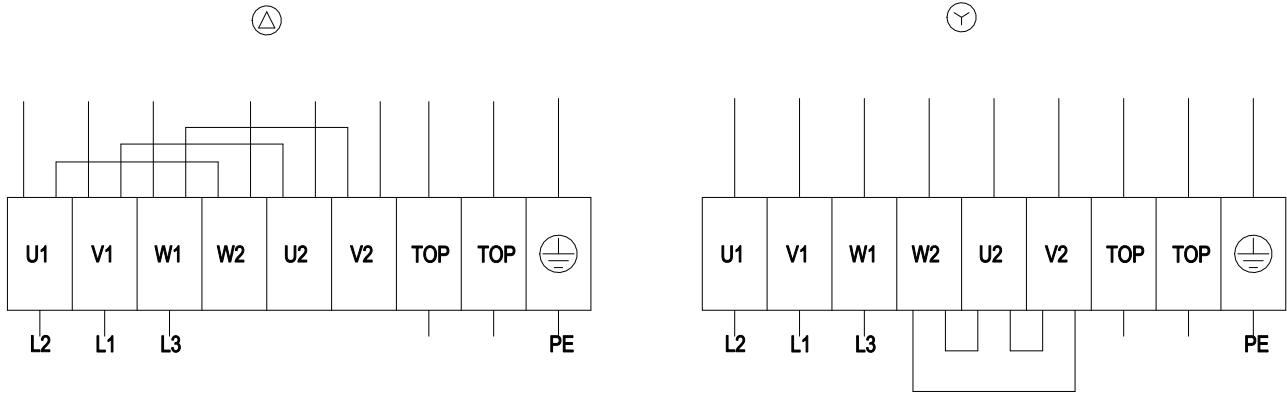

Δ	Delta connection	Y	Star connection	L1	= V1 = blue
L2	= U1 = black	L3	= W1 = brown	W2	yellow
U2	green	V2	white	TOP	2x gray
PE	green/yellow				

AC axial panel fan - HyBlade

sickle-shaped blades (S series)
with guard grille for short nozzle

Curves: Air performance 50 Hz

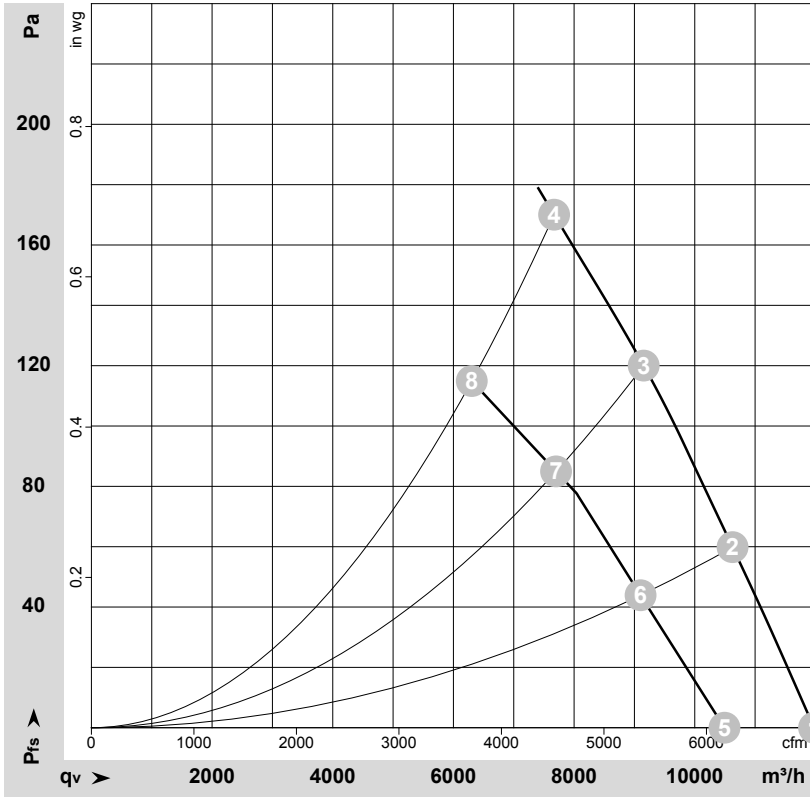

$\rho = 1.15 \text{ kg/m}^3 \pm 2 \%$

-111140-1
Date: 2026-05-19
-4037

-171088-1
Date: 2026-05-31
-4037

Air performance measured according to ISO 5801 installation category A. For detailed information on the measurement setup, contact ebm-papst. Intake sound level: Sound power level according to ISO 13347 / sound pressure level measured at 1 m distance from fan axis. The values given are valid under the specified measuring conditions and may vary due to conditions of installation. For deviations from the standard configuration, the parameters have to be checked on the installed unit.

Measured values

	Wired	U	f	n	P _e	I	LpA _{in}	LwA _{in}	LwA _{out}	q _v	p _{fs}	q _v	p _{fs}
		V	Hz	min ⁻¹	W	A	dB(A)	dB(A)	dB(A)	m ³ /h	Pa	cfm	in. wg
1	Δ	400	50	1400	806	1.98	69	76	76	11975	0	7050	0.00
2	Δ	400	50	1380	919	2.08	67	74	74	10625	60	6255	0.24
3	Δ	400	50	1365	1021	2.18	67	73	73	9155	120	5390	0.48
4	Δ	400	50	1350	1100	2.32	70	77	76	7670	170	4515	0.68
5	Y	400	50	1225	611	1.05	65	72	72	10495	0	6175	0.00
6	Y	400	50	1180	673	1.14	63	70	70	9100	44	5355	0.18
7	Y	400	50	1135	724	1.22	63	71	69	7700	85	4535	0.34
8	Y	400	50	1110	760	1.30	65	74	72	6305	115	3710	0.46

Wired = Wiring · U = Voltage · f = Frequency · n = Speed (rpm) · P_e = Power consumption · I = Current draw · LpA_{in} = Sound pressure level intake side · LwA_{in} = Sound power level intake side
LwA_{out} = Sound power level outlet side · q_v = Air flow · p_{fs} = Pressure increase

AC axial panel fan - HyBlade

sickle-shaped blades (S series)
with guard grille for short nozzle

Curves: Air performance 60 Hz

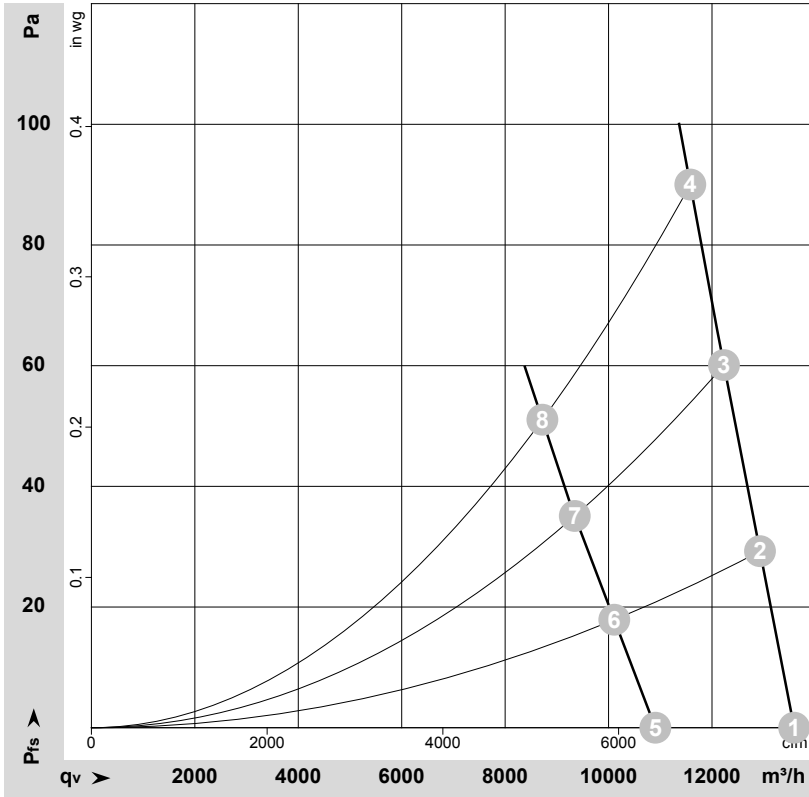

$\rho = 1.15 \text{ kg/m}^3 \pm 2 \%$

-119182-1
Date: 2026-05-01
-4037

-119183-1
Date: 2026-05-24
-4037

Air performance measured according to ISO 5801 installation category A. For detailed information on the measurement setup, contact ebm-papst. Intake sound level: Sound power level according to ISO 13347 / sound pressure level measured at 1 m distance from fan axis. The values given are valid under the specified measuring conditions and may vary due to conditions of installation. For deviations from the standard configuration, the parameters have to be checked on the installed unit.

Measured values

	Wired	U	f	n	P _e	I	LpA _{in}	LwA _{in}	LwA _{out}	q _v	p _{fs}	q _v	p _{fs}
		V	Hz	min ⁻¹	W	A	dB(A)	dB(A)	dB(A)	m ³ /h	Pa	cfm	in. wg
1	Δ	400	60	1605	1177	2.13	72	79	79	13590	0	8000	0.00
2	Δ	400	60	1585	1245	2.22	72	78	78	12930	30	7610	0.12
3	Δ	400	60	1565	1317	2.31	71	77	77	12230	60	7200	0.24
4	Δ	400	60	1540	1380	2.40	70	76	77	11580	90	6815	0.36
5	Y	400	60	1260	786	1.35	66	73	73	10905	0	6420	0.00
6	Y	400	60	1220	805	1.38	65	71	71	10110	18	5950	0.07
7	Y	400	60	1180	823	1.41	63	70	70	9345	35	5500	0.14
8	Y	400	60	1150	840	1.45	63	72	70	8720	50	5130	0.20

Wired = Wiring · U = Voltage · f = Frequency · n = Speed (rpm) · P_e = Power consumption · I = Current draw · LpA_{in} = Sound pressure level intake side · LwA_{in} = Sound power level intake side
LwA_{out} = Sound power level outlet side · q_v = Air flow · p_{fs} = Pressure increase