

AC axial fan - HyBlade

sickled blades (S series)

with guard grille for full nozzle

S4D500-CM03-09 ebmpapst Datasheet FansCo
 sales@fansco.com
 www.fansco.com

Nominal data

Type	S4D500-CM03-09				
Motor	M4D110-GF				
Phase		3~	3~	3~	3~
Nominal voltage	VAC	400	400	400	460
Connection		Δ	Y	Δ	Δ
Frequency	Hz	50	50	60	60
Type of data definition		ml	ml	ml	ml
Valid for approval / standard		CE	CE	CE	CE
Speed (rpm)	min ⁻¹	1390	1180	1590	1640
Power input	W	720	550	1020	1060
Current draw	A	1.41	0.9	1.7	1.64
Max. back pressure	Pa	140	100	130	138
Min. ambient temperature	°C	-40	-40	-40	-40
Max. ambient temperature	°C	65	65	50	60
Starting current	A	6.5	2.2	5.9	6.8

ml = Max. load · me = Max. efficiency · fa = Running at free air · cs = Customer specs · cu = Customer unit
 Subject to alterations

Data in accordance with ecodesign regulation EU 327/2011 (prEN 17166)

		Actual	Request 2015		
01 Overall efficiency η_{es}	%	35.2	32.7	09 Power input P_e	kW
02 Measurement category	A			09 Air flow q_v	m ³ /h
03 Efficiency category	Static			09 Pressure increase p_{fs}	Pa
04 Efficiency grade N	42.5	40		10 Speed (rpm) n	min ⁻¹
05 Variable speed drive	No			11 Specific ratio*	1.00

Data definition with optimum efficiency.

* Specific ratio = $1 + p_{fs} / 100\,000\text{ Pa}$

LU-197826

The indicated efficiency values for obtaining conformity with the Ecodesign Directive EU 327/2011 were achieved with defined air conduction components (e.g. inlet nozzles). The dimensions are to be requested from ebm-papst. If other air guide geometries are used on the installation side, the ebm-papst evaluation loses its validity/conformity must be confirmed again. The product does not fall within the scope of Regulation (EU) 2019/1781 due to the exception specified in Article 2(2a) (motors completely integrated into a product).

S4D500-CM03-09

Güntner GmbH & Co. KG

AC axial fan - HyBlade

sickled blades (S series)

with guard grille for full nozzle

Technical features

Mass	11.8 kg
Size	500 mm
Motor size	110
Surface of rotor	Coated in black
Material of terminal box	PP plastic
Material of blades	Press-fitted sheet steel blank, sprayed with PP plastic
Material of guard grille	Steel, coated in black plastic (RAL9005)
Number of blades	5
Direction of air flow	V
Direction of rotation	Counter-clockwise, seen on rotor
Type of protection	IP54
Insulation class	"F"
Humidity (F) / environmental protection class (H)	H2
Note ambient temperature	Occasional start-up between -40 °C and -25 °C is permissible. For continuous operation at ambient temperatures below -25 °C (e.g. refrigeration applications), a fan version with special low-temperature bearings must be used.
Max. permissible ambient motor temp. (transp./ storage)	+80 °C
Min. permissible ambient motor temp. (transp./storage)	-40 °C
Mounting position	Shaft horizontal or rotor on bottom; rotor on top on request
Condensation drainage holes	Rotor-side
Operation mode	S1
Motor bearing	Ball bearing
Touch current acc. IEC 60990 (measuring network Fig. 4, TN system)	<= 3.5 mA
Electrical connection	Terminal box
Motor protection	Thermal switch auto reset, lead out, with basic insulation
Cable exit	Axial
Protection class	I (if protective earth is connected by customer)
Product conforming to standard	EN 60034-1 (2010)
Standard conformity	UKCA
Product conforming to standard	CE
Approval	EAC; VDE

AC axial fan - HyBlade

sickled blades (S series)
 with guard grille for full nozzle

Product drawing

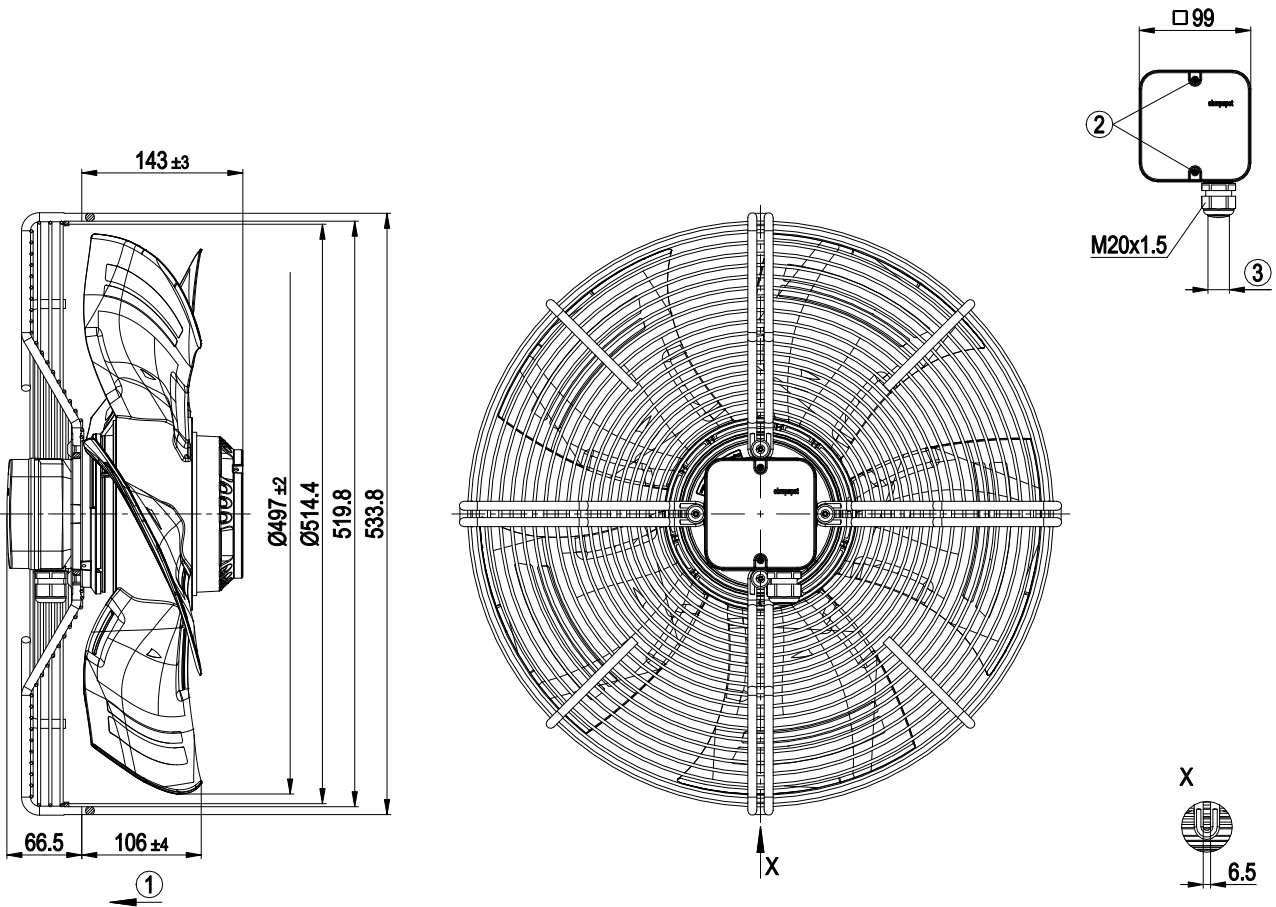

1	Direction of air flow "V"
2	Tightening torque 1.5 ± 0.2 Nm
3	Cable diameter min. 6 mm, max. 12 mm, tightening torque 2 ± 0.3 Nm

AC axial fan - HyBlade

sickled blades (S series)
 with guard grille for full nozzle

Connection screen

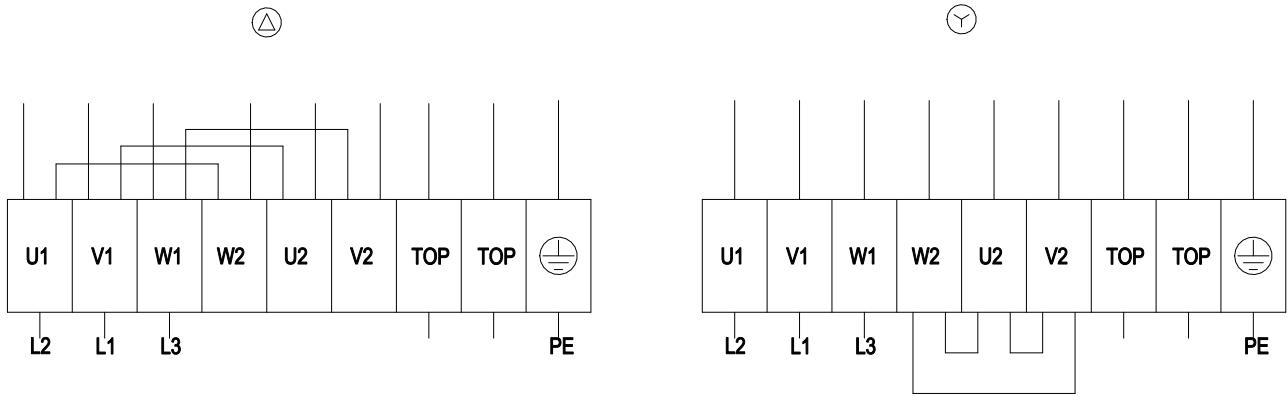

Δ	Delta connection	Y	Star connection	L1	= V1 = blue
L2	= U1 = black	L3	= W1 = brown	W2	yellow
U2	green	V2	white	TOP	2x grey
PE	green/yellow				

AC axial fan - HyBlade

sickled blades (S series)
with guard grille for full nozzle

Charts: Air flow 50 Hz

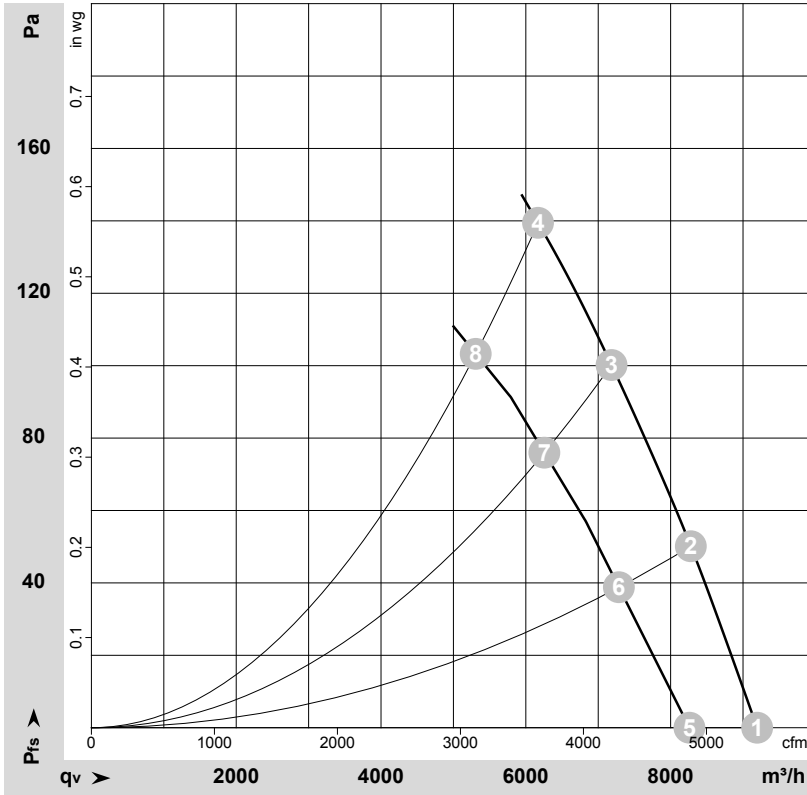

$\rho = 1.15 \text{ kg/m}^3 \pm 2 \%$

Measurement: LU-106631-1
Measurement: LU-106885-1

Air performance measured as per ISO 5801 Installation category A. For detailed information on the measuring set-up, please contact ebm-papst. Suction-side noise levels: LwA measured as per ISO 13347 / LpA measured with 1m distance to fan axis. The values given are valid under the measuring conditions mentioned above and may vary according to the actual installation situation. With any deviation from the standard set-up, the specific values have to be checked and reviewed with the unit installed.

Measured values

	Conn.	U	f	n	P _e	I	LpA _{in}	LwA _{in}	LwA _{out}	q _v	p _{fs}	q _v	p _{fs}
		V	Hz	min ⁻¹	W	A	dB(A)	dB(A)	dB(A)	m ³ /h	Pa	cfm	in. wg
1	Δ	400	50	1420	540	1.20	68	75	75	9195	0	5410	0.00
2	Δ	400	50	1410	605	1.28	65	72	72	8280	50	4875	0.20
3	Δ	400	50	1400	663	1.35	64	71	71	7185	100	4230	0.40
4	Δ	400	50	1390	720	1.41	64	72	72	6170	140	3630	0.56
5	Y	400	50	1275	433	0.71		72	73	8260	0	4860	0.00
6	Y	400	50	1240	478	0.78		70	70	7285	39	4290	0.16
7	Y	400	50	1215	518	0.85		68	68	6255	76	3680	0.31
8	Y	400	50	1180	550	0.90		68	68	5310	103	3125	0.41

Conn. = Connection · U = Supply voltage · f = Frequency · n = Speed (rpm) · P_e = Power input · I = Current draw · LpA_{in} = Sound pressure level inlet side · LwA_{in} = Sound power level inlet side
LwA_{out} = Sound power level outlet side · q_v = Air flow · p_{fs} = Pressure increase

AC axial fan - HyBlade

sickled blades (S series)
with guard grille for full nozzle

Charts: Air flow 60 Hz

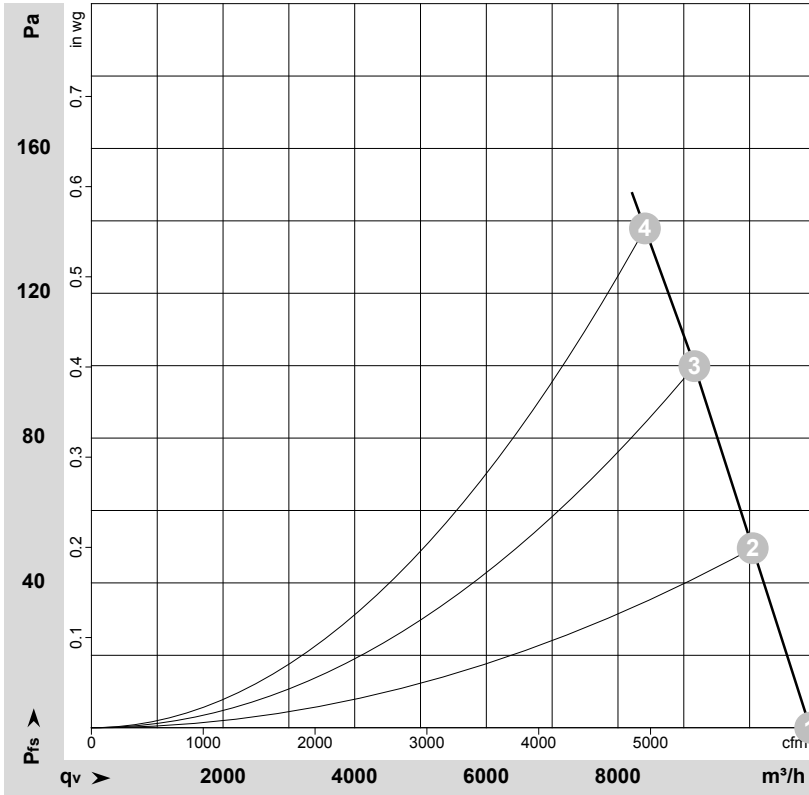

$\rho = 1.15 \text{ kg/m}^3 \pm 2 \%$

Measurement: LU-110160-1

Air performance measured as per ISO 5801 Installation category A. For detailed information on the measuring set-up, please contact ebmpapst. Suction-side noise levels: LwA measured as per ISO 13347 / LpA measured with 1m distance to fan axis. The values given are valid under the measuring conditions mentioned above and may vary according to the actual installation situation. With any deviation from the standard set-up, the specific values have to be checked and reviewed with the unit installed.

Measured values

	Conn.	U	f	n	P _e	I	LpA _{in}	LwA _{in}	LwA _{out}	q _v	p _{fs}	q _v	p _{fs}
		V	Hz	min ⁻¹	W	A	dB(A)	dB(A)	dB(A)	m ³ /h	Pa	cfm	in. wg
1	Δ	460	60	1680	854	1.41	71	79	79	10920	0	6430	0.00
2	Δ	460	60	1670	930	1.49	70	77	77	10045	50	5915	0.20
3	Δ	460	60	1655	1008	1.58	68	75	75	9160	100	5390	0.40
4	Δ	460	60	1640	1060	1.64	68	75	75	8410	138	4950	0.55

Conn. = Connection · U = Supply voltage · f = Frequency · n = Speed (rpm) · P_e = Power input · I = Current draw · LpA_{in} = Sound pressure level inlet side · LwA_{in} = Sound power level inlet side
LwA_{out} = Sound power level outlet side · q_v = Air flow · p_{fs} = Pressure increase