

S4D500-AM09-21 ebmpapst Datasheet

sales@fansco.com

www.fansco.com

Limited partnership · Headquarters Muldingen

Amtsgericht (court of registration) Stuttgart · HRA 590344

General partner Elektrobau Muldingen GmbH · Headquarters Muldingen

Amtsgericht (court of registration) Stuttgart · HRB 590142



Nominal data

Type	S4D500-AM09-21				
Motor	M4D110-GF				
Phase		3~	3~	3~	3~
Nominal voltage	VAC	400	400	480	480
Wiring		Δ	Y	Δ	Y
Frequency	Hz	50	50	60	60
Method of obtaining data		ml	ml	ml	ml
Valid for approval/standard		CE	CE	CE	CE
Speed (rpm)	min ⁻¹	1350	1100	1590	1250
Power consumption	W	690	480	1050	690
Current draw	A	1.34	0.81	1.57	0.98
Max. back pressure	Pa	155	105	160	100
Max. back pressure	inH ₂ O	0.62	0.42	0.64	0.4
Min. ambient temperature	°C	-40	-40	-40	-40
Max. ambient temperature	°C	65	65	60	60
Starting current	A	6.5		7.5	

ml = Max. load · me = Max. efficiency · fa = Free air · cs = Customer specification · ce = Customer equipment
Subject to change

Data according to ErP Directive

		Actual	Req. 2015			
01 Overall efficiency η_{es}	%	33.4	32.6	09 Power consumption P_e	kW	0.67
02 Measurement category		A		09 Air flow q_v	m ³ /h	5950
03 Efficiency category		Static		09 Pressure increase p_{fs}	Pa	137
04 Efficiency grade N		40.8	40	10 Speed (rpm) n	min ⁻¹	1355
05 Variable speed drive		No		11 Specific ratio*		1.00

Data obtained at optimum efficiency level.

The ErP data is determined using a motor-impeller combination in a standardized measurement setup.

* Specific ratio = $1 + p_s / 100\,000\text{ Pa}$

LU-105632



AC axial fan - HyBlade

sickle-shaped blades (S series)

with guard grille for short nozzle

Technical description

Weight	13 kg
Fan size	500 mm
Rotor surface	Painted black
Terminal box material	PP plastic
Blade material	Press-fitted sheet steel blank, sprayed with PP plastic
Guard grille material	Steel, coated with black plastic (RAL 9005)
Number of blades	5
Airflow direction	"V"
Direction of rotation	Counterclockwise, viewed toward rotor
Degree of protection	IP54
Insulation class	"F"
Moisture (F) / Environmental (H) protection class	F4-1
Max. permitted ambient temp. for motor (transport/storage)	+ 80 °C
Min. permitted ambient temp. for motor (transport/storage)	- 40 °C
Installation position	Shaft horizontal or rotor on bottom; rotor on top on request
Condensation drainage holes	On rotor side
Mode	S1
Motor bearing	Ball bearing
Touch current according to IEC 60990 (measuring circuit Fig. 4, TN system)	<= 3.5 mA
Electrical hookup	Via terminal box
Motor protection	Thermal overload protector (TOP) with basic insulation
With cable	Axial
Protection class	I (with customer connection of protective earth)
Conformity with standards	EN 60034; CE
Approval	EAC; VDE



AC axial fan - HyBlade

sickle-shaped blades (S series)
with guard grille for short nozzle

Product drawing

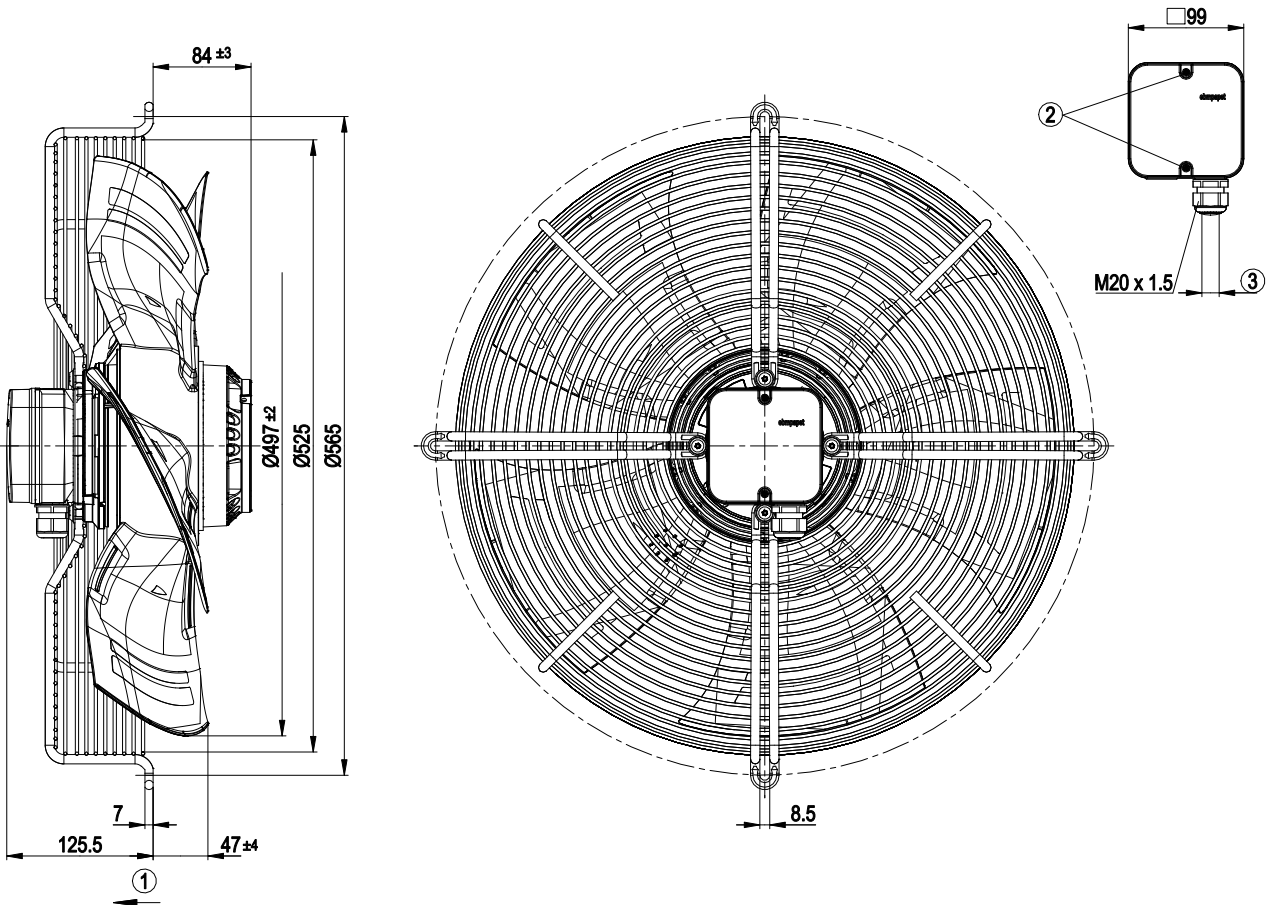

1	Direction of air flow "V"
2	Tightening torque 1.5 ± 0.2 Nm
3	Cable diameter: min. 6 mm, max. 12 mm, tightening torque 2±0.3 Nm



AC axial fan - HyBlade

sickle-shaped blades (S series)
with guard grille for short nozzle

Connection diagram



Δ	Delta connection	Y	Star connection	L1	= V1 = blue
L2	= U1 = black	L3	= W1 = brown	W2	yellow
U2	green	V2	white	TOP	2x gray
PE	green/yellow				



Curves: Air performance 50 Hz

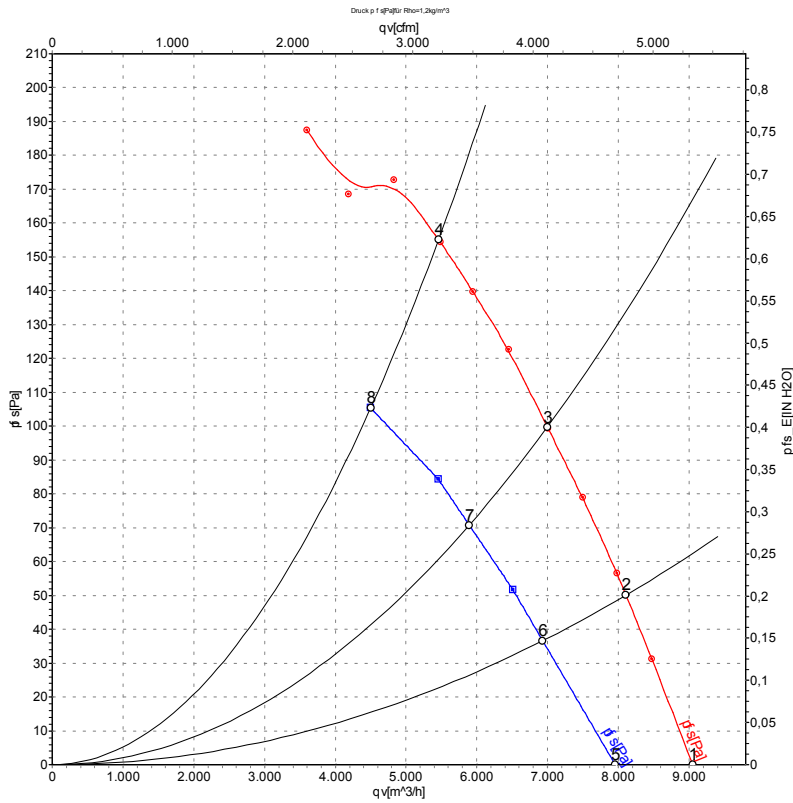

Measurement: LU-105632-1
Measurement: LU-106081-1

Air performance measured according to ISO 5801 installation category A. For detailed information on the measurement setup, contact ebm-papst. Intake sound level: Sound power level according to ISO 13347 / sound pressure level measured at 1 m distance from fan axis. The values given are valid under the specified measuring conditions and may vary due to conditions of installation. For deviations from the standard configuration, the parameters have to be checked on the installed unit.

Measured values

	Wired	U	f	n	P _e	I	LpA _{in}	LwA _{in}	LwA _{out}	qv	p _{fs}	qv	p _{fs}
		V	Hz	min ⁻¹	W	A	dB(A)	dB(A)	dB(A)	m ³ /h	Pa	CFM	inH2O
1	Δ	400	50	1395	504	1.13	68	75	75	9050	0	5325	0.00
2	Δ	400	50	1380	570	1.19	65	72	72	8110	50	4775	0.20
3	Δ	400	50	1365	628	1.26	64	71	71	6995	100	4120	0.40
4	Δ	400	50	1350	690	1.34	65	72	72	5460	155	3215	0.62
5	Y	400	50	1220	386	0.65	65	72	72	7955	0	4680	0.00
6	Y	400	50	1180	418	0.70	62	69	69	6930	37	4080	0.15
7	Y	400	50	1140	449	0.75	60	67	67	5895	71	3470	0.29
8	Y	400	50	1100	480	0.81	59	67	66	4500	105	2650	0.42

Wired = Wiring · U = Power supply · f = Frequency · n = Speed (rpm) · P_e = Power consumption · I = Current draw · LpA_{in} = Sound pressure level intake side · LwA_{in} = Sound power level intake side
LwA_{out} = Sound power level outlet side · qv = Air flow · p_{fs} = Pressure increase



AC axial fan - HyBlade

sickle-shaped blades (S series)
with guard grille for short nozzle

Curves: Air performance 60 Hz

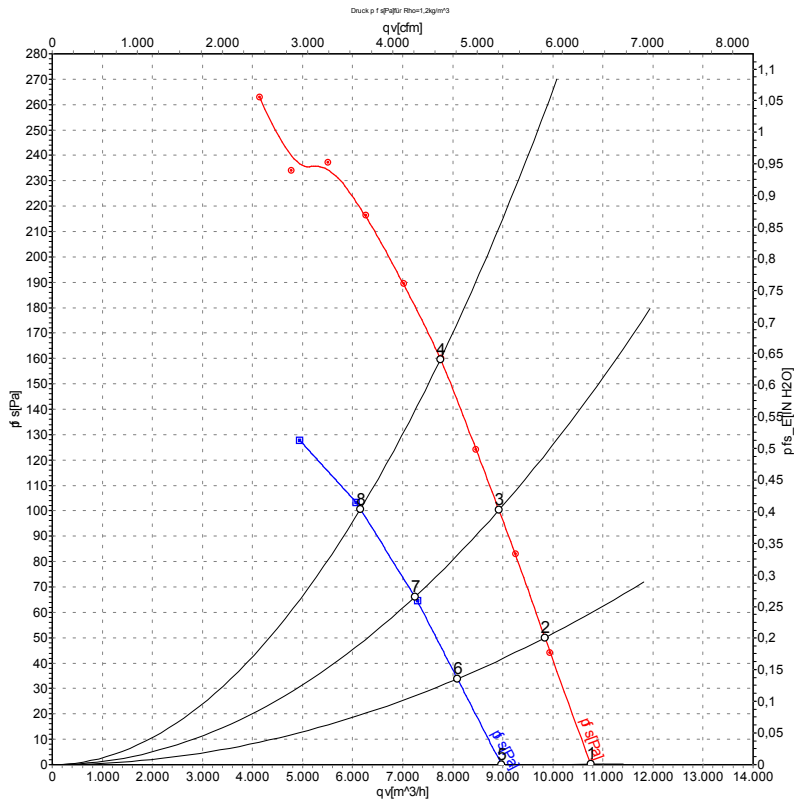

Measurement: LU-105633-1
Measurement: LU-106114-1

Air performance measured according to ISO 5801 installation category A. For detailed information on the measurement setup, contact ebm-papst. Intake sound level: Sound power level according to ISO 13347 / sound pressure level measured at 1 m distance from fan axis. The values given are valid under the specified measuring conditions and may vary due to conditions of installation. For deviations from the standard configuration, the parameters have to be checked on the installed unit.

Measured values

	Wired	U	f	n	P _e	I	LpA _{in}	LwA _{in}	LwA _{out}	qv	p _{fs}	qv	p _{fs}
		V	Hz	min ⁻¹	W	A	dB(A)	dB(A)	dB(A)	m ³ /h	Pa	CFM	inH2O
1	Δ	480	60	1645	824	1.32	71	78	79	10760	0	6335	0.00
2	Δ	480	60	1630	895	1.39	69	76	77	9840	50	5790	0.20
3	Δ	480	60	1610	969	1.47	68	75	75	8925	100	5250	0.40
4	Δ	480	60	1590	1050	1.57	67	75	75	7755	160	4565	0.64
5	Y	480	60	1375	599	0.84	67	74	75	8975	0	5280	0.00
6	Y	480	60	1330	632	0.89	65	72	72	8095	34	4765	0.14
7	Y	480	60	1290	662	0.93	63	70	70	7245	66	4265	0.26
8	Y	480	60	1250	690	0.98	62	69	68	6160	100	3625	0.40

Wired = Wiring · U = Power supply · f = Frequency · n = Speed (rpm) · P_e = Power consumption · I = Current draw · LpA_{in} = Sound pressure level intake side · LwA_{in} = Sound power level intake side
LwA_{out} = Sound power level outlet side · qv = Air flow · p_{fs} = Pressure increase

