

# AC axial fan

sickle-shaped blades (S series)  
with guard grille for short nozzle

S4D450-GA14-22 ebmpapst Datasheet  
sales@fansco.com  
www.fansco.com

Limited partnership · Headquarters Muldingen  
Amtsgericht (court of registration) Stuttgart · HRA 590344

General partner Elektrobau Muldingen GmbH · Headquarters Muldingen  
Amtsgericht (court of registration) Stuttgart · HRB 590142



## Nominal data

| Type                        | S4D450-GA14-22     |      |      |      |      |
|-----------------------------|--------------------|------|------|------|------|
| Motor                       | M4D094-HA          |      |      |      |      |
| Phase                       |                    | 3~   | 3~   | 3~   | 3~   |
| Nominal voltage             | VAC                | 400  | 400  | 400  | 400  |
| Wiring                      |                    | Δ    | Y    | Δ    | Y    |
| Frequency                   | Hz                 | 50   | 50   | 60   | 60   |
| Method of obtaining data    |                    | fa   | fa   | fa   | fa   |
| Valid for approval/standard |                    | CE   | CE   | CE   | CE   |
| Speed (rpm)                 | min <sup>-1</sup>  | 1410 | 1220 | 1610 | 1200 |
| Power consumption           | W                  | 355  | 270  | 535  | 360  |
| Current draw                | A                  | 0.85 | 0.47 | 1.17 | 0.63 |
| Max. back pressure          | Pa                 | 200  | 110  | 110  | 55   |
| Max. back pressure          | inH <sub>2</sub> O | 0.8  | 0.44 | 0.44 | 0.22 |
| Min. ambient temperature    | °C                 | -40  | -40  | -40  | -40  |
| Max. ambient temperature    | °C                 | 70   | 70   | 50   | 50   |
| Starting current            | A                  | 3.9  | 1.3  | 3.5  | 1.2  |

ml = Max. load · me = Max. efficiency · fa = Free air · cs = Customer specification · ce = Customer equipment  
Subject to change

## Data according to ErP Directive

|                                   | Actual | Req. 2015 |      |                               |                   |      |
|-----------------------------------|--------|-----------|------|-------------------------------|-------------------|------|
| 01 Overall efficiency $\eta_{es}$ | %      | 39.4      | 31.3 | 09 Power consumption $P_e$    | kW                | 0.42 |
| 02 Measurement category           | A      |           |      | 09 Air flow $q_v$             | m <sup>3</sup> /h | 4500 |
| 03 Efficiency category            | Static |           |      | 09 Pressure increase $p_{fs}$ | Pa                | 135  |
| 04 Efficiency grade N             | 48.1   | 40        |      | 10 Speed (rpm) n              | min <sup>-1</sup> | 1385 |
| 05 Variable speed drive           | No     |           |      | 11 Specific ratio*            |                   | 1.00 |

Data obtained at optimum efficiency level.  
The ErP data is determined using a motor-impeller combination in a standardized measurement setup.

\* Specific ratio =  $1 + p_{fs} / 100\,000\text{ Pa}$

LU-106884



# AC axial fan

sickle-shaped blades (S series)  
with guard grille for short nozzle

## Technical description

|  |  |
|--|--|
| Weight   | 10.4 kg  |
| Fan size   | 450 mm   |
| Rotor surface  | Painted black  |
| Terminal box material  | ABS plastic  |
| Impeller material  | Sheet steel, painted black                                   |
| Guard grille material  | Steel, coated with black plastic (RAL 9005)                  |
| Number of blades   | 5  |
| Airflow direction  | "V"  |
| Direction of rotation  | Counterclockwise, viewed toward rotor                        |
| Degree of protection   | IP54   |
| Insulation class   | "F"  |
| Moisture (F) / Environmental (H) protection class                          | F3-1   |
| Max. permitted ambient temp. for motor (transport/storage)                 | + 80 °C  |
| Min. permitted ambient temp. for motor (transport/storage)                 | - 40 °C  |
| Installation position  | Shaft horizontal or rotor on bottom; rotor on top on request |
| Condensation drainage holes  | On rotor side  |
| Mode   | S1   |
| Motor bearing  | Ball bearing   |
| Touch current according to IEC 60990 (measuring circuit Fig. 4, TN system) | <= 3.5 mA  |
| Electrical hookup  | Via terminal box   |
| Motor protection   | Thermal overload protector (TOP) with basic insulation       |
| Protection class   | I (with customer connection of protective earth)             |
| Conformity with standards  | EN 60034-1 (2010); CE  |



# AC axial fan

sickle-shaped blades (S series)  
with guard grille for short nozzle

## Product drawing

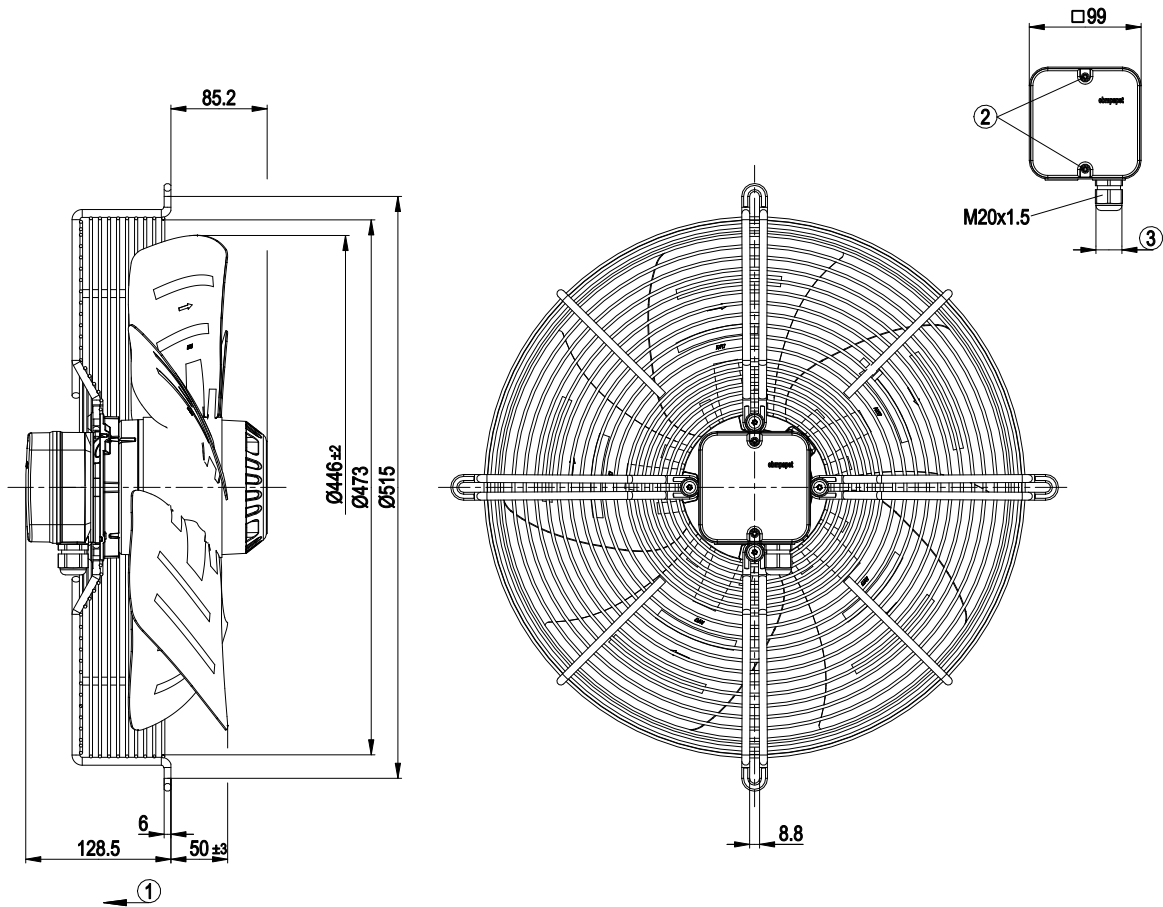

|   |  |
|---|--|
| 1 | Direction of air flow "V"  |
| 2 | Tightening torque 0.8 ± 0.15 Nm                                    |
| 3 | Cable diameter: min. 6 mm, max. 12 mm; tightening torque 2±0.15 Nm |



# AC axial fan

sickle-shaped blades (S series)  
with guard grille for short nozzle

## Connection diagram



|    |                  |    |                 |     |              |
|----|------------------|----|-----------------|-----|--------------|
| Δ  | Delta connection | Y  | Star connection | L1  | = U1 = black |
| L2 | = V1 = blue      | L3 | = W1 = brown    | W2  | yellow       |
| U2 | green            | V2 | white           | TOP | 2x gray      |
| PE | green/yellow     |    |                 |     |              |



# AC axial fan

sickle-shaped blades (S series)  
with guard grille for short nozzle

## Curves: Air performance 50 Hz

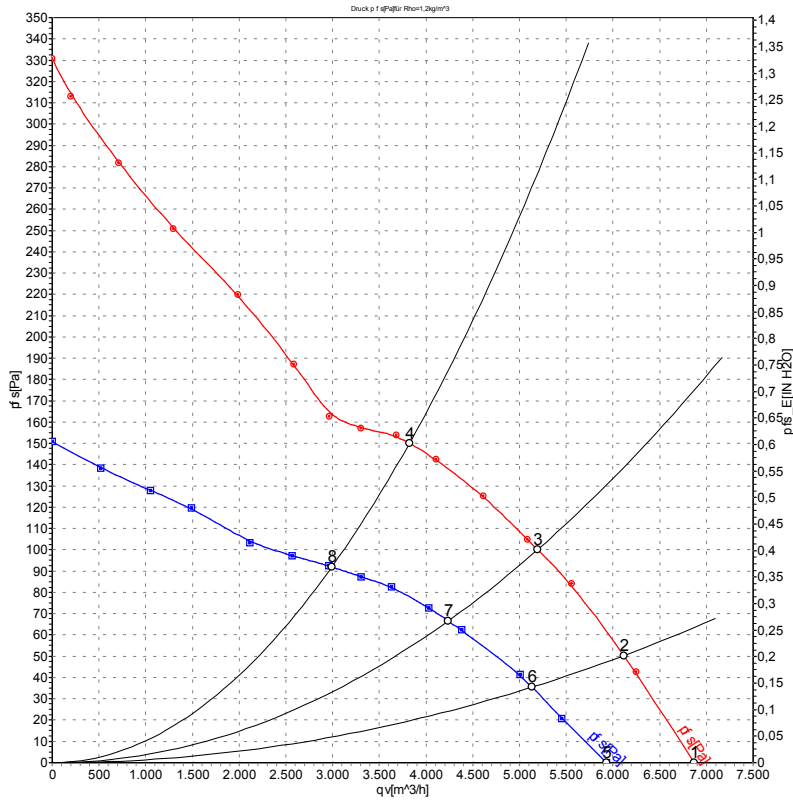

Measurement: LU-54525-1  
Measurement: LU-54528-1

Air performance measured according to ISO 5801 installation category A. For detailed information on the measurement setup, contact ebm-papst. Intake sound level: Sound power level according to ISO 13347 / sound pressure level measured at 1 m distance from fan axis. The values given are valid under the specified measuring conditions and may vary due to conditions of installation. For deviations from the standard configuration, the parameters have to be checked on the installed unit.

## Measured values

|   | U   | f  | n                 | P <sub>e</sub> | I    | qv                | p <sub>fs</sub> | qv   | p <sub>fs</sub> |
|---|-----|----|-------------------|----------------|------|-------------------|-----------------|------|-----------------|
|   | V   | Hz | min <sup>-1</sup> | W              | A    | m <sup>3</sup> /h | Pa              | CFM  | inH2O           |
| 1 | 400 | 50 | 1410              | 355            | 0.85 | 6870              | 0               | 4045 | 0.00            |
| 2 | 400 | 50 | 1400              | 397            | 0.89 | 6115              | 50              | 3600 | 0.20            |
| 3 | 400 | 50 | 1385              | 437            | 0.94 | 5195              | 100             | 3055 | 0.40            |
| 4 | 400 | 50 | 1370              | 482            | 0.99 | 3825              | 150             | 2250 | 0.60            |
| 5 | 400 | 50 | 1220              | 270            | 0.47 | 5930              | 0               | 3490 | 0.00            |
| 6 | 400 | 50 | 1180              | 300            | 0.51 | 5135              | 36              | 3020 | 0.14            |
| 7 | 400 | 50 | 1135              | 323            | 0.55 | 4235              | 67              | 2495 | 0.27            |
| 8 | 400 | 50 | 1080              | 353            | 0.60 | 2990              | 92              | 1760 | 0.37            |

U = Power supply · f = Frequency · n = Speed (rpm) · P<sub>e</sub> = Power consumption · I = Current draw · qv = Air flow · p<sub>fs</sub> = Pressure increase



# AC axial fan

sickle-shaped blades (S series)  
with guard grille for short nozzle

## Curves: Air performance 60 Hz

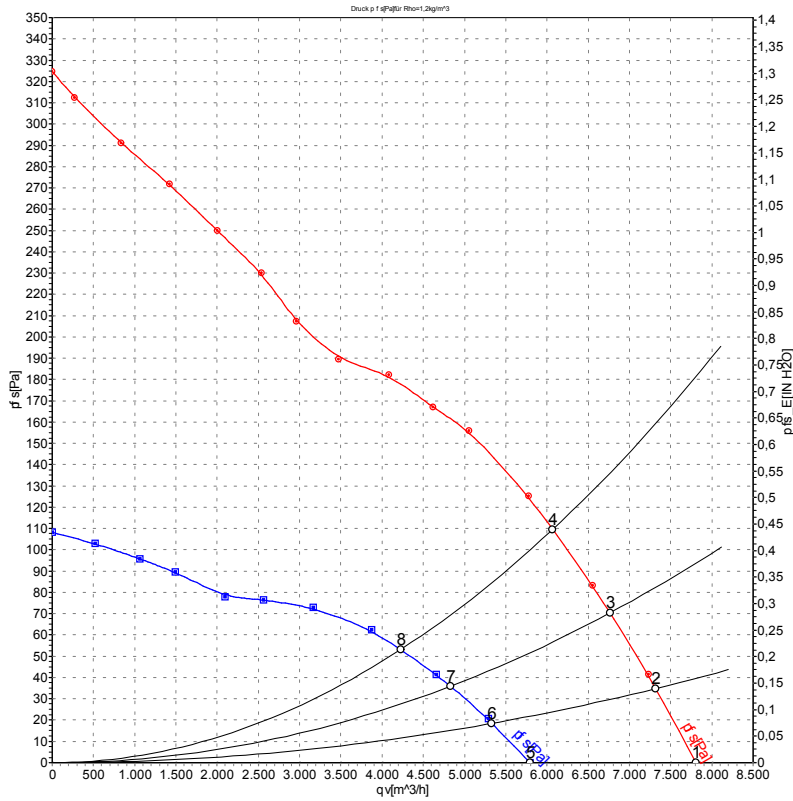

Measurement: LU-54526-1  
Measurement: LU-54529-1

Air performance measured according to ISO 5801 installation category A. For detailed information on the measurement setup, contact ebm-papst. Intake sound level: Sound power level according to ISO 13347 / sound pressure level measured at 1 m distance from fan axis. The values given are valid under the specified measuring conditions and may vary due to conditions of installation. For deviations from the standard configuration, the parameters have to be checked on the installed unit.

## Measured values

|   | U   | f  | n                 | P <sub>e</sub> | I    | q <sub>v</sub> | p <sub>fs</sub> | q <sub>v</sub> | p <sub>fs</sub> |
|---|-----|----|-------------------|----------------|------|----------------|-----------------|----------------|-----------------|
|   | V   | Hz | min <sup>-1</sup> | W              | A    | m³/h           | Pa              | CFM            | inH2O           |
| 1 | 400 | 60 | 1610              | 535            | 0.98 | 7810           | 0               | 4595           | 0.00            |
| 2 | 400 | 60 | 1590              | 571            | 1.03 | 7315           | 35              | 4305           | 0.14            |
| 3 | 400 | 60 | 1570              | 606            | 1.08 | 6765           | 70              | 3980           | 0.28            |
| 4 | 400 | 60 | 1540              | 660            | 1.16 | 6070           | 110             | 3575           | 0.44            |
| 5 | 400 | 60 | 1200              | 360            | 0.63 | 5800           | 0               | 3415           | 0.00            |
| 6 | 400 | 60 | 1155              | 374            | 0.65 | 5330           | 19              | 3135           | 0.08            |
| 7 | 400 | 60 | 1115              | 384            | 0.67 | 4830           | 36              | 2840           | 0.14            |
| 8 | 400 | 60 | 1060              | 400            | 0.70 | 4225           | 55              | 2485           | 0.22            |

U = Power supply · f = Frequency · n = Speed (rpm) · P<sub>e</sub> = Power consumption · I = Current draw · q<sub>v</sub> = Air flow · p<sub>fs</sub> = Pressure increase

