

S4D450-BP01-02 ebmpapst Datasheet FansCo

sales@fansco.com

www.fansco.com

Nominal data

Type	S4D450-BP01-02				
Motor	M4D074-GA				
Phase		3~	3~	3~	3~
Nominal voltage	VAC	230	230	400	400
Wiring		Δ	Δ	Y	Y
Frequency	Hz	50	60	50	60
Method of obtaining data		fa	fa	fa	fa
Valid for approval/standard		CE	CE	CE	CE
Speed (rpm)	min ⁻¹	1380	1540	1380	1540
Power consumption	W	200	285	200	285
Current draw	A	0.83	0.92	0.48	0.53
Max. back pressure	Pa	120	70	120	70
Max. back pressure	inH ₂ O	0.48	0.28	0.48	0.28
Min. ambient temperature	°C	-25	-25	-25	-25
Max. ambient temperature	°C	50	50	50	50

ml = Max. load · me = Max. efficiency · fa = Free air · cs = Customer specification · ce = Customer equipment

Subject to change

Data according to ErP Directive

		Actual	Req. 2015		
01 Overall efficiency η_{es}	%	34.9	30.1	09 Power consumption P_e	kW 0.27
02 Measurement category	A			09 Air flow q_v	m ³ /h 3795
03 Efficiency category	Static			09 Pressure increase p_{fs}	Pa 91
04 Efficiency grade N	44.8	40		10 Speed (rpm) n	min ⁻¹ 1310
05 Variable speed drive	No			11 Specific ratio*	1.00

Data obtained at optimum efficiency level.

The ErP data is determined using a motor-impeller combination in a standardized measurement setup.

* Specific ratio = $1 + p_g / 100\,000\text{ Pa}$

LU-27634



AC axial fan

sickle-shaped blades (S series)
with guard grille for full nozzle

Technical description

Weight	5.0 kg
Fan size	450 mm
Rotor surface	Painted black
Blade material	Sheet steel, painted black
Guard grille material	Steel, phosphated and coated with black plastic
Number of blades	5
Airflow direction	"A"
Direction of rotation	Clockwise, viewed toward rotor
Degree of protection	IP44
Insulation class	"F"
Moisture (F) / Environmental (H) protection class	H0+
Max. permitted ambient temp. for motor (transport/storage)	+ 80 °C
Min. permitted ambient temp. for motor (transport/storage)	- 40 °C
Installation position	Shaft horizontal or rotor on bottom; rotor on top on request
Condensation drainage holes	On rotor side
Mode	S1
Motor bearing	Ball bearing
Touch current according to IEC 60990 (measuring circuit Fig. 4, TN system)	< 0.75 mA
With cable	Variable
Protection class	I (with customer connection of protective earth)
Conformity with standards	EN 60335-1



AC axial fan

sickle-shaped blades (S series)
with guard grille for full nozzle

Product drawing

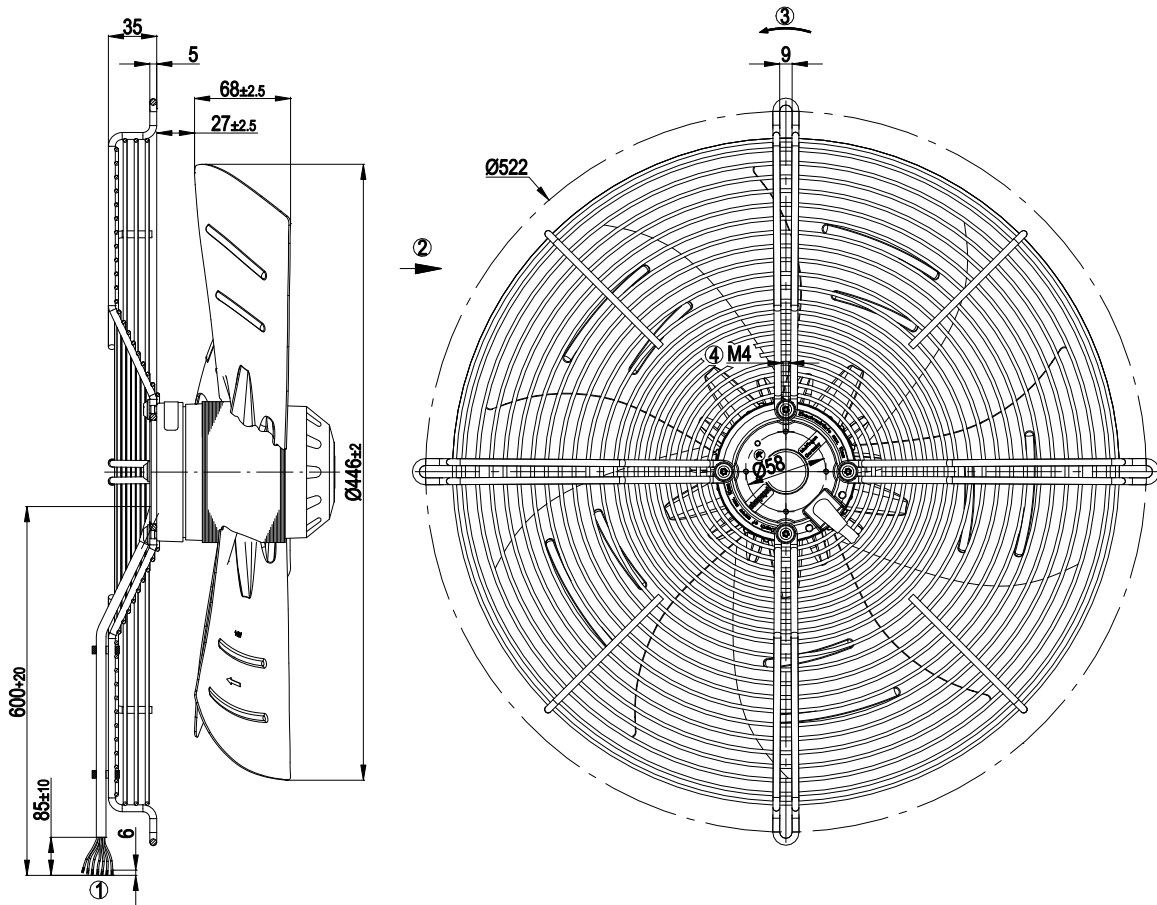

- | | |
|---|--|
| 1 | Cable Dipotherm, 7x crimped splices |
| 2 | Direction of air flow "A" |
| 3 | Direction of rotation clockwise, viewed toward rotor |
| 4 | Max. clearance for screw 10 mm |



AC axial fan

sickle-shaped blades (S series)
with guard grille for full nozzle

Connection diagram

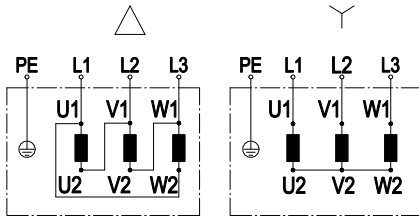

Change of rotation direction by reversing two phases

	Three-phase motor	Δ	Delta connection	Y	Star connection
L1	= U1 = black	L2	= V1 = blue	L3	= W1 = brown
U2	green	V2	white	W2	yellow
PE	green/yellow				

AC axial fan

sickle-shaped blades (S series)
with guard grille for full nozzle

Curves: Air performance 50 Hz

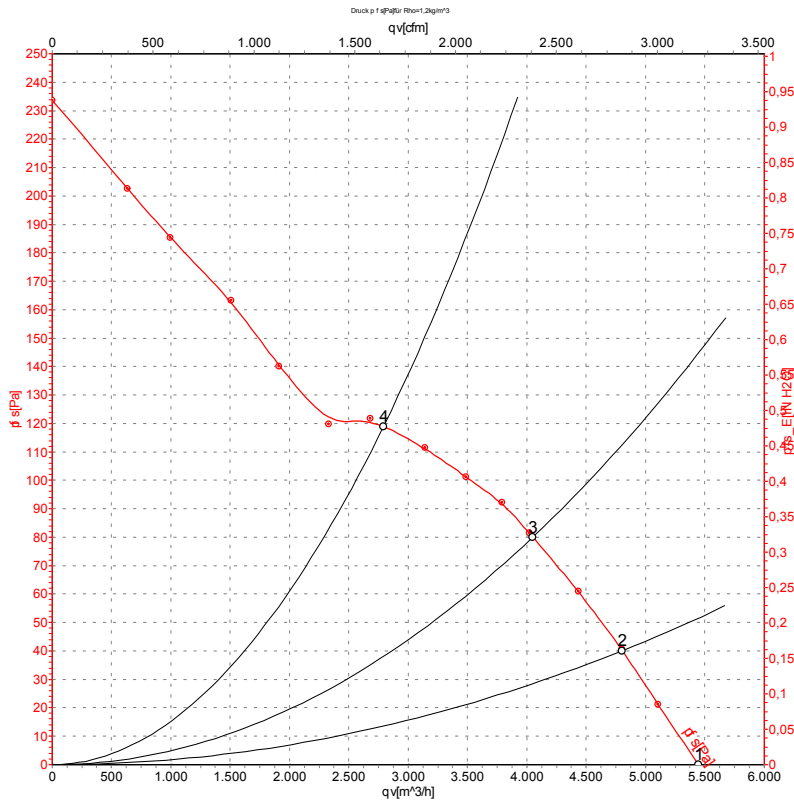

Measurement: LU-27634-1

Air performance measured according to ISO 5801 installation category A. For detailed information on the measurement setup, contact ebm-papst. Intake sound level: Sound power level according to ISO 13347 / sound pressure level measured at 1 m distance from fan axis. The values given are valid under the specified measuring conditions and may vary due to conditions of installation. For deviations from the standard configuration, the parameters have to be checked on the installed unit.

Measured values

	U	f	n	P _e	I	qv	p _{fs}	qv	p _{fs}
	V	Hz	min ⁻¹	W	A	m ³ /h	Pa	CFM	inH ₂ O
1	400	50	1380	200	0.48	5445	0	3205	0.00
2	400	50	1345	235	0.53	4800	40	2825	0.16
3	400	50	1320	264	0.57	4050	80	2385	0.32
4	400	50	1285	301	0.61	2790	120	1645	0.48

U = Power supply · f = Frequency · n = Speed (rpm) · P_e = Power consumption · I = Current draw · qv = Air flow · p_{fs} = Pressure increase



AC axial fan

sickle-shaped blades (S series)
with guard grille for full nozzle

Curves: Air performance 60 Hz

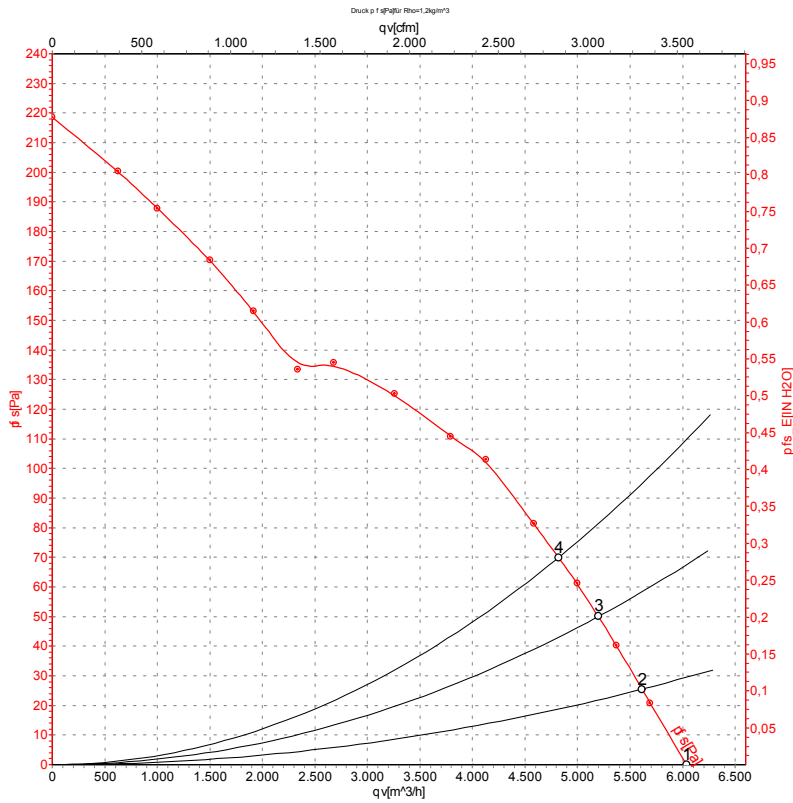

Measurement: LU-27635-1

Air performance measured according to ISO 5801 installation category A. For detailed information on the measurement setup, contact ebm-papst. Intake sound level: Sound power level according to ISO 13347 / sound pressure level measured at 1 m distance from fan axis. The values given are valid under the specified measuring conditions and may vary due to conditions of installation. For deviations from the standard configuration, the parameters have to be checked on the installed unit.

Measured values

	U	f	n	P _e	I	qv	p _{fs}	qv	p _{fs}
	V	Hz	min ⁻¹	W	A	m ³ /h	Pa	CFM	inH ₂ O
1	400	60	1540	285	0.53	6040	0	3555	0.00
2	400	60	1505	314	0.58	5615	25	3305	0.10
3	400	60	1475	337	0.62	5200	50	3060	0.20
4	400	60	1450	355	0.64	4820	70	2835	0.28

U = Power supply · f = Frequency · n = Speed (rpm) · P_e = Power consumption · I = Current draw · qv = Air flow · p_{fs} = Pressure increase

