

AC axial fan

sickle-shaped blades (S series)
with guard grille, for rail applications

S4D450-BO14-14 ebmpapst Datasheet
sales@fansco.com
www.fansco.com

Limited partnership · Headquarters Muldingen
Amtsgericht (court of registration) Stuttgart · HRA 590344
General partner Elektrobau Muldingen GmbH · Headquarters Muldingen
Amtsgericht (court of registration) Stuttgart · HRB 590142

Nominal data

Type	S4D450-BO14-14		
Motor	M4D094-HA		
Phase		3~	3~
Nominal voltage	VAC	400	400
Wiring		Δ	Y
Frequency	Hz	50	50
Method of obtaining data		ml	ml
Valid for approval/standard		-	-
Speed (rpm)	min ⁻¹	1360	1100
Power consumption	W	450	325
Current draw	A	0.95	0.55
Max. back pressure	Pa	130	85
Max. back pressure	in. wg	0.52	0.34
Min. ambient temperature	°C	-40	-40
Max. ambient temperature	°C	60	60
Starting current	A	3.6	1.2

ml = Max. load · me = Max. efficiency · fa = Free air · cs = Customer specification · ce = Customer equipment
Subject to change



AC axial fan

sickle-shaped blades (S series)
with guard grille, for rail applications

Technical description

Weight	9.6 kg
Size	450 mm
Motor size	94
Rotor surface	Painted black
Blade material	Press-fitted sheet steel blank, sprayed with PA plastic
Guard grille material	Steel, coated with black plastic (RAL 9005)
Number of blades	5
Airflow direction	A
Direction of rotation	Clockwise, viewed toward rotor
Degree of protection	IP55
Insulation class	"F"
Moisture (F) / Environmental (H) protection class	H2
Ambient temperature note	Occasional start-up at temperatures between -40°C and -25°C is permitted. For continuous operation at ambient temperatures below -25°C (such as refrigeration applications), use must be made of a fan design with special low-temperature bearings.
Max. permitted ambient temp. for motor (transport/storage)	+80 °C
Min. permitted ambient temp. for motor (transport/storage)	-40 °C
Installation position	Shaft horizontal or rotor on bottom; rotor on top on request
Condensation drainage holes	On rotor side
Mode	S1
Motor bearing	Ball bearing; (sealed)
Touch current according to IEC 60990 (measuring circuit Fig. 4, TN system)	<= 3.5 mA
Motor protection	Thermal overload protector (TOP) with basic insulation
Protection class	I (with customer connection of protective earth)
Conformity with standards	CE
Approval	EAC



AC axial fan

sickle-shaped blades (S series)
with guard grille, for rail applications

Product drawing

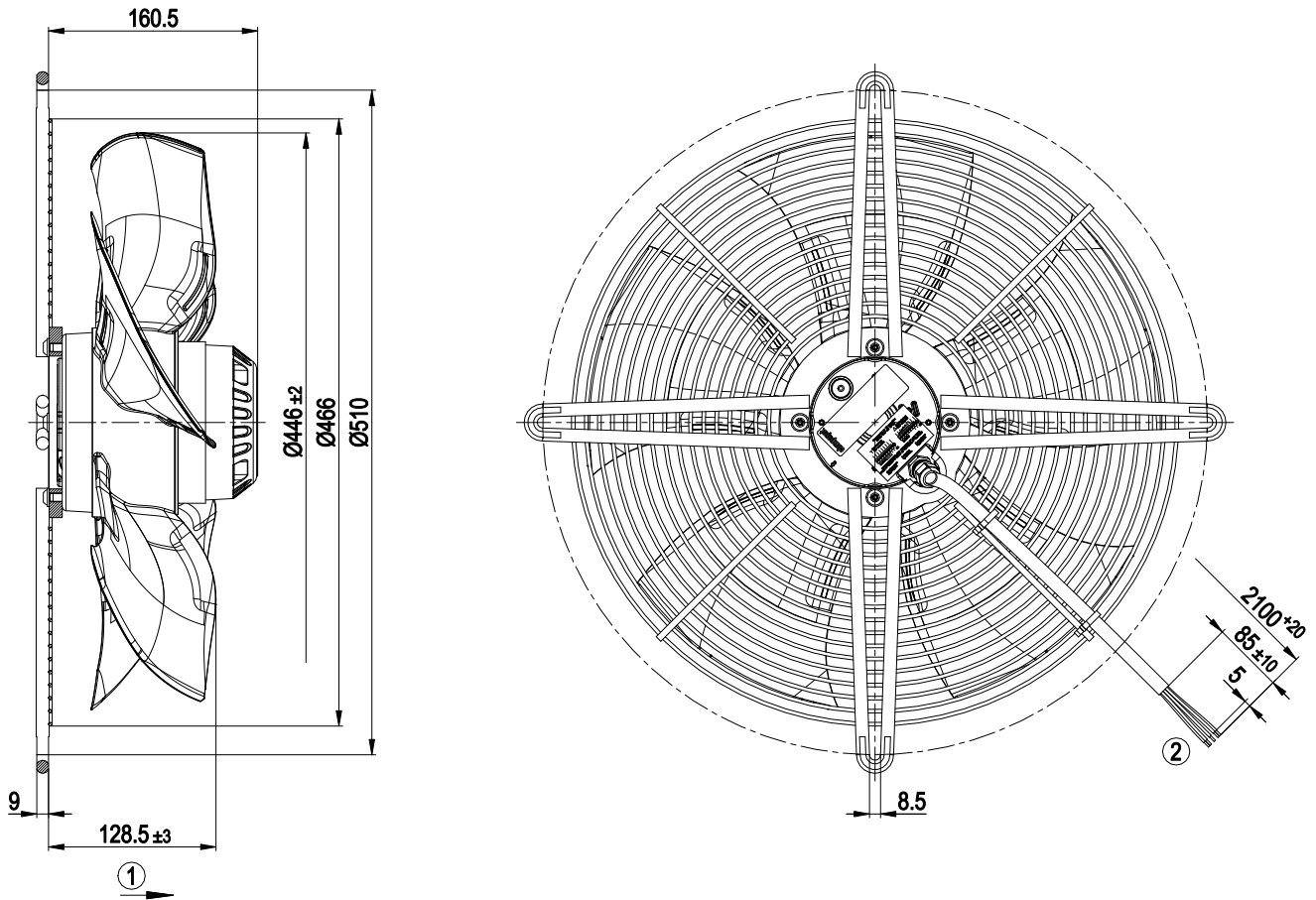

1	Direction of air flow "A"
2	Cable halogen-free, BETAtans® GKW flex R, 9G 0.5 mm ²
	9x splice



AC axial fan

sickle-shaped blades (S series)
with guard grille, for rail applications

Connection diagram

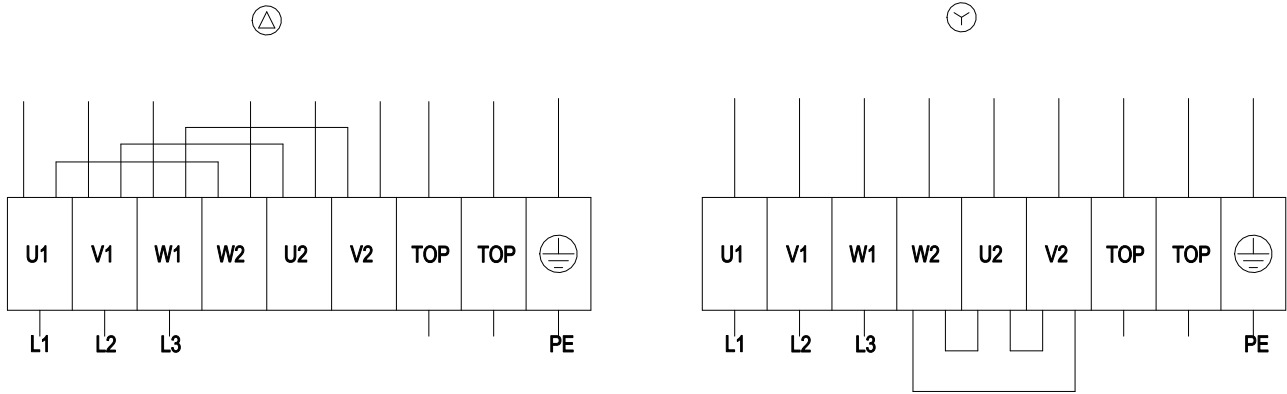

Δ	Delta connection	Y	Star connection	L1	= U1 = black
L2	= V1 = blue	L3	= W1 = brown	W2	yellow
U2	green	V2	white	TOP	2x gray
PE	green/yellow				



AC axial fan

sickle-shaped blades (S series)
with guard grille, for rail applications

Curves: Air performance 50 Hz

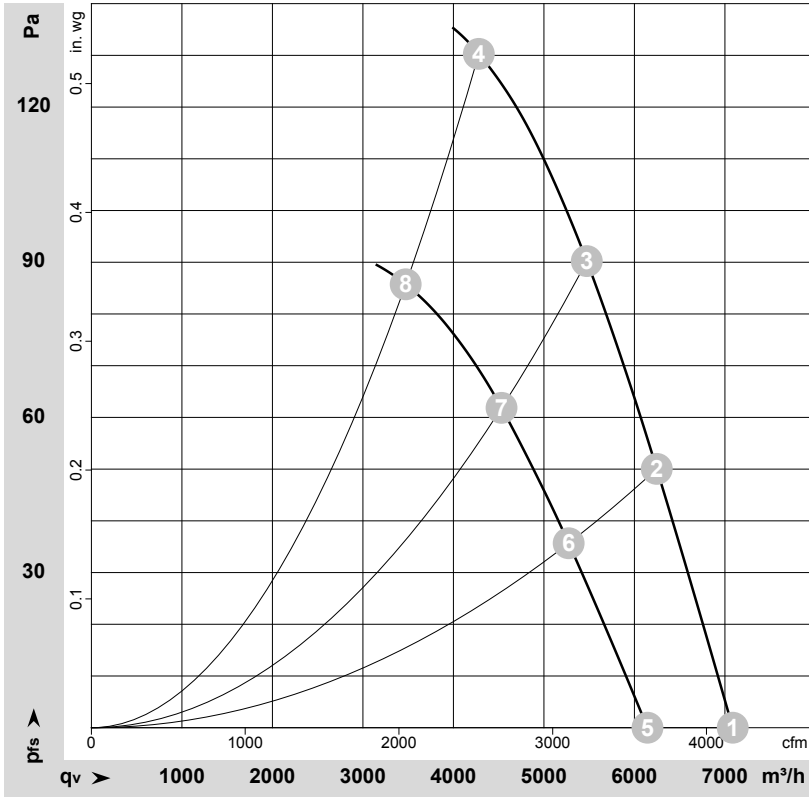

$\rho = 1.15 \text{ kg/m}^3 \pm 2 \%$

Measurement: LU-180418-1
Measurement: LU-180611-1

Air performance measured according to ISO 5801 installation category A. For detailed information on the measurement setup, contact ebm-papst. Intake sound level: Sound power level according to ISO 13347 / sound pressure level measured at 1 m distance from fan axis. The values given are valid under the specified measuring conditions and may vary due to conditions of installation. For deviations from the standard configuration, the parameters have to be checked on the installed unit.

Measured values

	Wired	U	f	n	P _e	I	LpA _{in}	LwA _{in}	LwA _{out}	q _v	p _{fs}	q _v	p _{fs}
		V	Hz	min ⁻¹	W	A	dB(A)	dB(A)	dB(A)	m ³ /h	Pa	cfm	in. wg
1	Δ	400	50	1405	346	0.84	67	74	72	7085	0	4170	0.00
2	Δ	400	50	1385	391	0.88	63	70	71	6245	50	3675	0.20
3	Δ	400	50	1375	422	0.91	62	68	70	5475	90	3220	0.36
4	Δ	400	50	1360	450	0.95	64	71	72	4280	130	2520	0.52
5	Y	400	50	1215	264	0.45	64	70	71	6145	0	3615	0.00
6	Y	400	50	1170	292	0.49	60	66	67	5275	36	3105	0.14
7	Y	400	50	1135	309	0.52	58	64	65	4530	62	2665	0.25
8	Y	400	50	1100	325	0.55	59	66	67	3475	86	2045	0.35

Wired = Wiring · U = Voltage · f = Frequency · n = Speed (rpm) · P_e = Power consumption · I = Current draw · LpA_{in} = Sound pressure level intake side · LwA_{in} = Sound power level intake side
LwA_{out} = Sound power level outlet side · q_v = Air flow · p_{fs} = Pressure increase

