

# AC axial fan - HyBlade

sickle-shaped blades (S series)

with guard grille for short nozzle

S4D450-AN14-02 ebmpapst Datasheet

sales@fansco.com

www.fansco.com

## Nominal data

<b>Type</b>	<b>S4D450-AN14-02</b>		
<b>Motor</b>	<b>M4D094-FA</b>		
Phase		3~	3~
Nominal voltage	VAC	400	400
Wiring		$\Delta$	Y
Frequency	Hz	50	50
Method of obtaining data		ml	ml
Valid for approval/standard		CE	CE
Speed (rpm)	min <sup>-1</sup>	1330	1040
Power consumption	W	460	310
Current draw	A	0.95	0.52
Max. back pressure	Pa	130	78
Max. back pressure	inH <sub>2</sub> O	0.52	0.31
Min. ambient temperature	°C	-25	-25
Max. ambient temperature	°C	65	65
Starting current	A	3.3	1.1

ml = Max. load · me = Max. efficiency · fa = Free air · cs = Customer specification · ce = Customer equipment  
Subject to change

## Data according to Commission Regulation (EU) 327/2011

		Actual	Req. 2015			
01 Overall efficiency $\eta_{es}$	%	34.3	31.5	09 Power consumption $P_e$	kW	0.45
02 Measurement category		A		09 Air flow $q_v$	m <sup>3</sup> /h	4530
03 Efficiency category		Static		09 Pressure increase $p_{fs}$	Pa	124
04 Efficiency grade N		42.8	40	10 Speed (rpm) n	min <sup>-1</sup>	1335
05 Variable speed drive		No		11 Specific ratio*		1.00

Data obtained at optimum efficiency level.  
The ErP data is determined using a motor-impeller combination in a standardized measurement setup.

\* Specific ratio =  $1 + p_{fs} / 100\,000\text{ Pa}$

LU-108389



# AC axial fan - HyBlade

sickle-shaped blades (S series)

with guard grille for short nozzle

## Technical description

<b>Weight</b>	8.5 kg
<b>Fan size</b>	450 mm
<b>Rotor surface</b>	Painted black
<b>Terminal box material</b>	ABS plastic
<b>Blade material</b>	PP plastic
<b>Guard grille material</b>	Steel, coated with black plastic (RAL 9005)
<b>Number of blades</b>	5
<b>Airflow direction</b>	"A"
<b>Direction of rotation</b>	Clockwise, viewed toward rotor
<b>Degree of protection</b>	IP54
<b>Insulation class</b>	"F"
<b>Moisture (F) / Environmental (H) protection class</b>	F4-1
<b>Ambient temperature note</b>	Occasional start-up between -40°C and -25°C is permissible. For continuous operation at temperatures below -25°C (e.g. refrigeration applications) we recommend our fan design with special low-temperature bearings.
<b>Max. permitted ambient temp. for motor (transport/storage)</b>	+ 80 °C
<b>Min. permitted ambient temp. for motor (transport/storage)</b>	- 40 °C
<b>Installation position</b>	Shaft horizontal or rotor on bottom; rotor on top on request
<b>Condensation drainage holes</b>	On rotor side
<b>Mode</b>	S1
<b>Motor bearing</b>	Ball bearing
<b>Touch current according to IEC 60990 (measuring circuit Fig. 4, TN system)</b>	<= 3.5 mA
<b>Electrical hookup</b>	Via terminal box
<b>Motor protection</b>	Thermal overload protector (TOP) with basic insulation
<b>Protection class</b>	I (with customer connection of protective earth)
<b>Conformity with standards</b>	EN 60034-1 (2010); CE
<b>Approval</b>	EAC



# AC axial fan - HyBlade

sickle-shaped blades (S series)  
with guard grille for short nozzle

## Product drawing

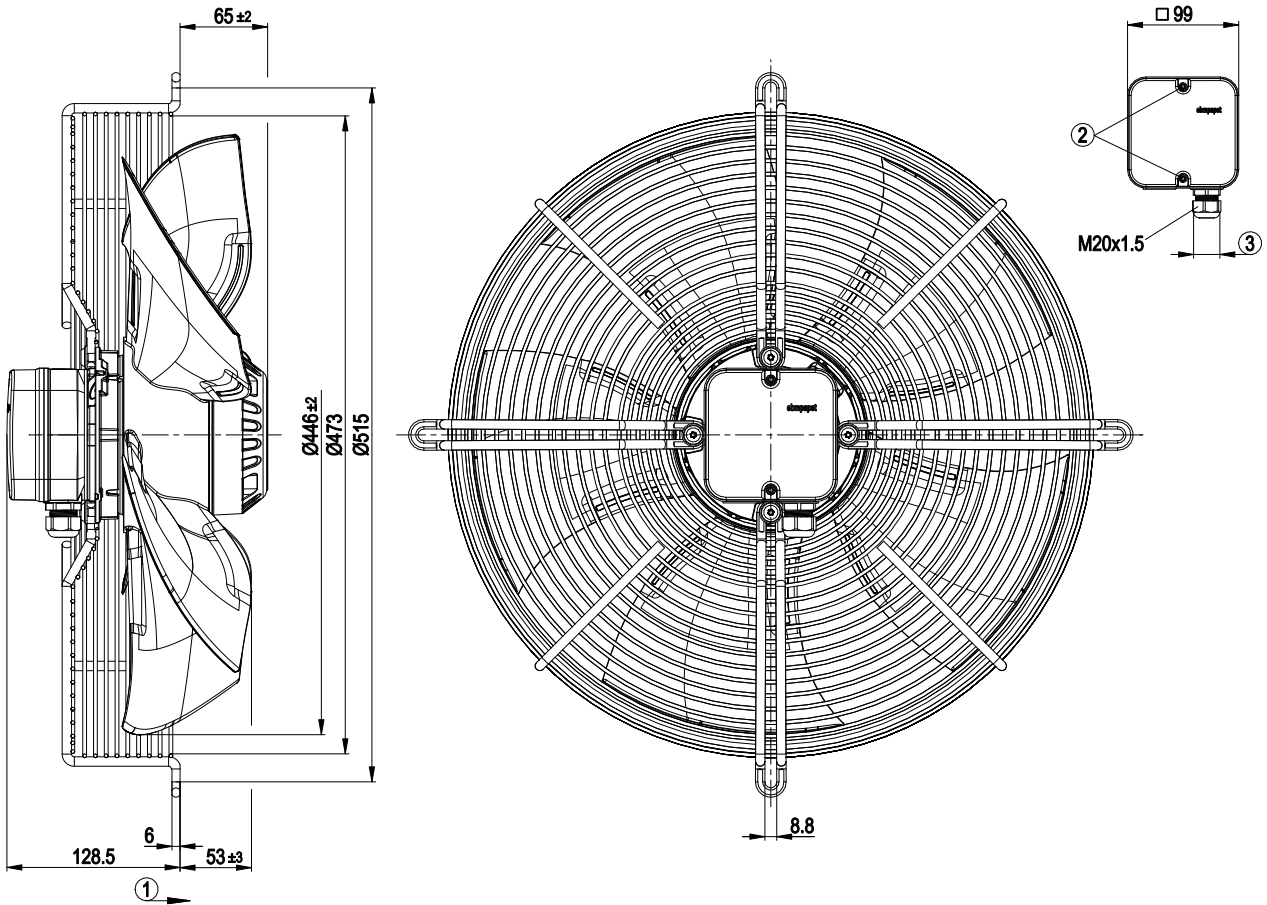

1	Direction of air flow "A"
2	Tightening torque 0.8 ± 0.15 Nm
3	Cable diameter min. 6 mm, max. 12 mm; tightening torque 2 ± 0.2 Nm



# AC axial fan - HyBlade

sickle-shaped blades (S series)  
with guard grille for short nozzle

## Connection diagram

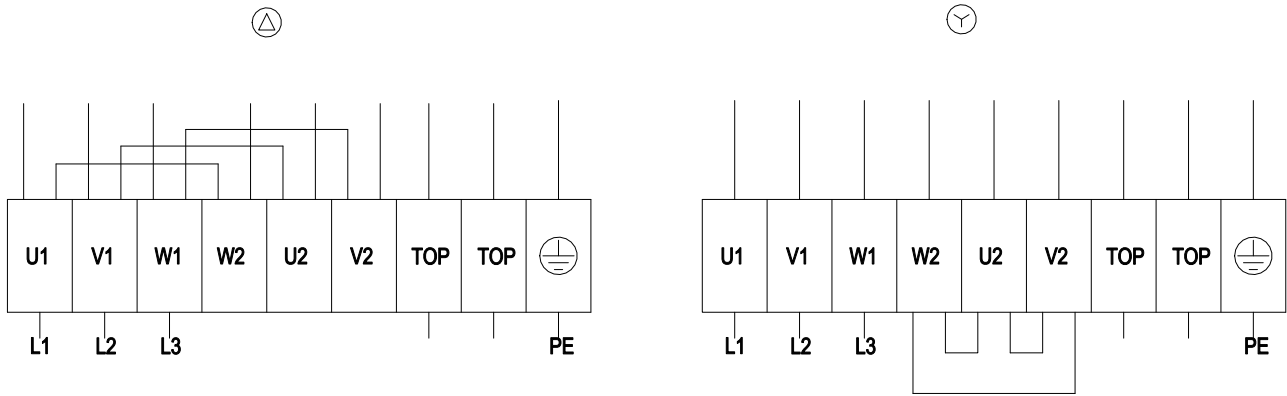

Δ	Delta connection	Y	Star connection	L1	= U1 = black
L2	= V1 = blue	L3	= W1 = brown	W2	yellow
U2	green	V2	white	TOP	2x gray
PE	green/yellow				



## Curves: Air performance 50 Hz

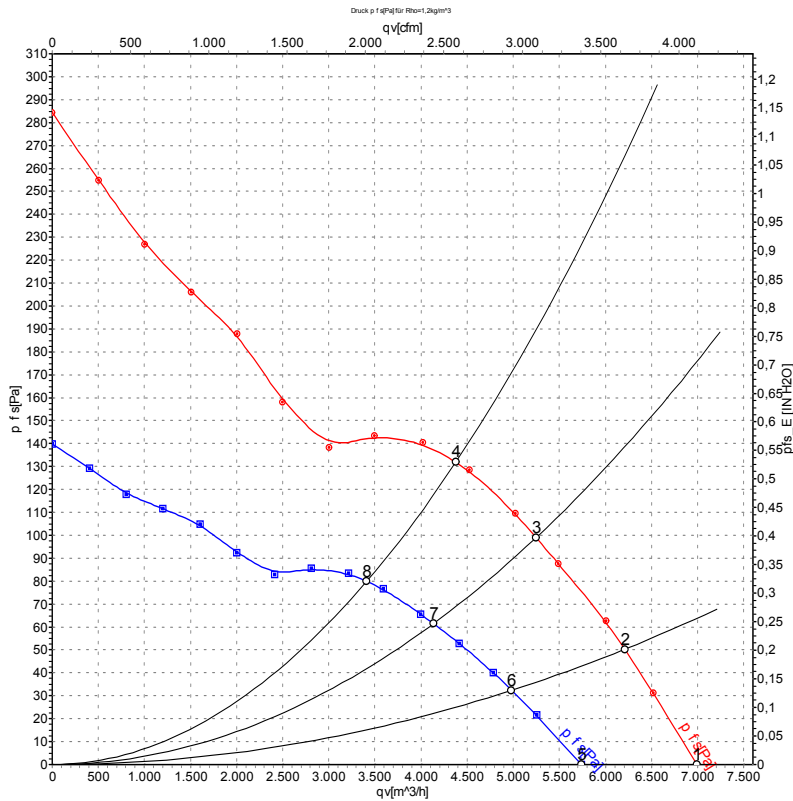

Measurement: LU-108389-1  
Measurement: LU-108390-1

Air performance measured according to ISO 5801 installation category A. For detailed information on the measurement setup, contact ebm-papst. Intake sound level: Sound power level according to ISO 13347 / sound pressure level measured at 1 m distance from fan axis. The values given are valid under the specified measuring conditions and may vary due to conditions of installation. For deviations from the standard configuration, the parameters have to be checked on the installed unit.

## Measured values

	Wired	U	f	n	P <sub>e</sub>	I	LpA <sub>in</sub>	LwA <sub>in</sub>	q <sub>v</sub>	P <sub>fs</sub>	q <sub>v</sub>	P <sub>fs</sub>
		V	Hz	min <sup>-1</sup>	W	A	dB(A)	dB(A)	m <sup>3</sup> /h	Pa	cfm	inH <sub>2</sub> O
1	Δ	400	50	1375	369	0.86	65	71	6995	0	4115	0.00
2	Δ	400	50	1360	410	0.90	62	68	6210	50	3655	0.20
3	Δ	400	50	1345	440	0.93	61	68	5250	100	3090	0.40
4	Δ	400	50	1330	460	0.95	62	69	4380	130	2575	0.52
5	Y	400	50	1145	269	0.45	61	67	5740	0	3375	0.00
6	Y	400	50	1090	293	0.49	58	64	4980	32	2930	0.13
7	Y	400	50	1060	306	0.51	56	62	4135	62	2435	0.25
8	Y	400	50	1040	310	0.52	57	63	3410	80	2005	0.32

Wired = Wiring · U = Power supply · f = Frequency · n = Speed (rpm) · P<sub>e</sub> = Power consumption · I = Current draw · LpA<sub>in</sub> = Sound pressure level intake side · LwA<sub>in</sub> = Sound power level intake side  
q<sub>v</sub> = Air flow · P<sub>fs</sub> = Pressure increase

