

S4D420-BU02-31 ebmpapst Datasheet

sales@fansco.com

www.fansco.com

Limited partnership · Headquarters Mulfingen

Amtsgericht (court of registration) Stuttgart · HRA 590344

General partner Elektrobau Mulfingen GmbH · Headquarters Mulfingen

Amtsgericht (court of registration) Stuttgart · HRB 590142

Nominal data

Type	S4D420-BU02-31				
Motor	M4D094-EA				
Phase		3~	3~	3~	3~
Nominal voltage	VAC	400	400	400	400
Wiring		Δ	Y	Δ	Y
Frequency	Hz	50	50	60	60
Method of obtaining data		ml	ml	ml	ml
Valid for approval/standard		CE	CE	CE	CE
Speed (rpm)	min ⁻¹	1360	1060	1490	970
Power consumption	W	260	185	385	220
Current draw	A	0.52	0.31	0.65	0.37
Max. back pressure	Pa	95	60	110	47
Max. back pressure	in. wg	0.38	0.24	0.44	0.19
Min. ambient temperature	°C	-40	-40	-40	-40
Max. ambient temperature	°C	60	60	60	60
Starting current	A	1.7	0.55	1.57	0.51

ml = Max. load · me = Max. efficiency · fa = Free air · cs = Customer specification · ce = Customer equipment
Subject to change

Data according to Commission Regulation (EU) 327/2011 (EN 17166)

		Actual	Req. 2015		
01 Overall efficiency η_{es}	%	31.4	30	09 Power consumption P_e	kW 0.26
02 Measurement category		A		09 Air flow q_v	m ³ /h 3205
03 Efficiency category		Static		09 Pressure increase p_{fs}	Pa 96
04 Efficiency grade N		41.4	40	10 Speed (rpm) n	min ⁻¹ 1350
05 Variable speed drive		No		11 Specific ratio*	1.00

Data obtained at optimum efficiency level.
The ErP data is determined using a motor-impeller combination in a standardized measurement setup.

* Specific ratio = $1 + p_{fs} / 100\,000\text{ Pa}$

LU-72485



AC axial fan

sickle-shaped blades (S series)
with guard grille for short nozzle

Technical description

Weight	6.1 kg
Size	420 mm
Motor size	94
Rotor surface	Painted black
Terminal box material	PP plastic
Blade material	Press-fitted sheet steel blank, sprayed with PP plastic
Guard grille material	Steel, coated with black plastic (RAL 9005)
Number of blades	5
Airflow direction	A
Direction of rotation	Clockwise, viewed toward rotor
Degree of protection	IP54
Insulation class	"F"
Moisture (F) / Environmental (H) protection class	H2
Ambient temperature note	Occasional start-up at temperatures between -40°C and -25°C is permitted. For continuous operation at ambient temperatures below -25°C (such as refrigeration applications), use must be made of a fan design with special low-temperature bearings.
Max. permitted ambient temp. for motor (transport/storage)	+80 °C
Min. permitted ambient temp. for motor (transport/storage)	-40 °C
Installation position	Shaft horizontal or rotor on bottom; rotor on top on request
Condensation drainage holes	On rotor side
Mode	S1
Motor bearing	Ball bearing
Touch current according to IEC 60990 (measuring circuit Fig. 4, TN system)	<= 3.5 mA
Electrical hookup	Terminal box
Motor protection	Thermal overload protector (TOP) with basic insulation
Protection class	I (with customer connection of protective earth)
Conformity with standards	EN 60034-1 (2010); CE
Approval	EAC



AC axial fan

sickle-shaped blades (S series)
with guard grille for short nozzle

Product drawing

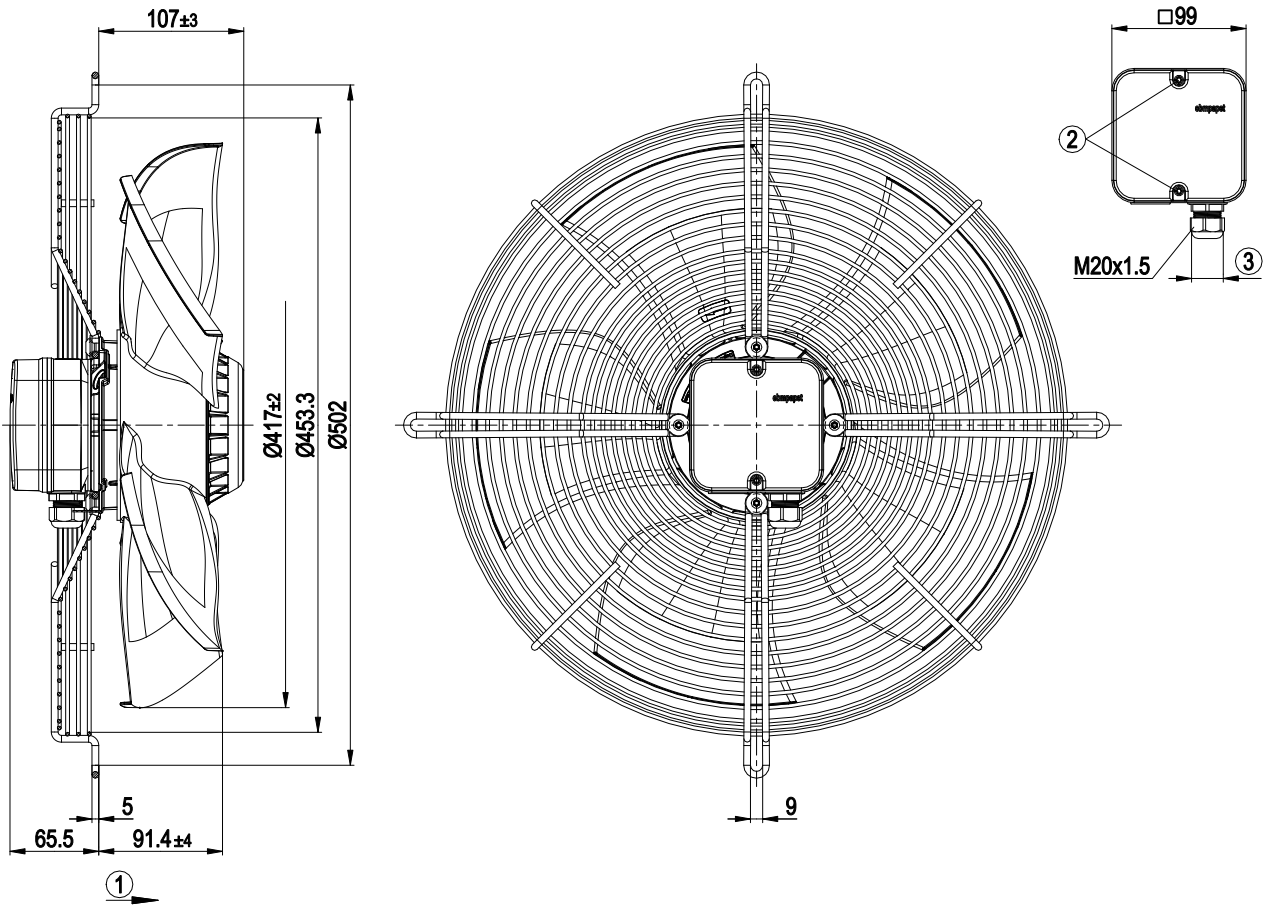

1	Direction of air flow "A"
2	Tightening torque 1.5 ± 0.2 Nm
3	Cable diameter min. 6 mm, max. 12 mm, tightening torque 2 ± 0.3 Nm



AC axial fan

sickle-shaped blades (S series)
with guard grille for short nozzle

Connection diagram

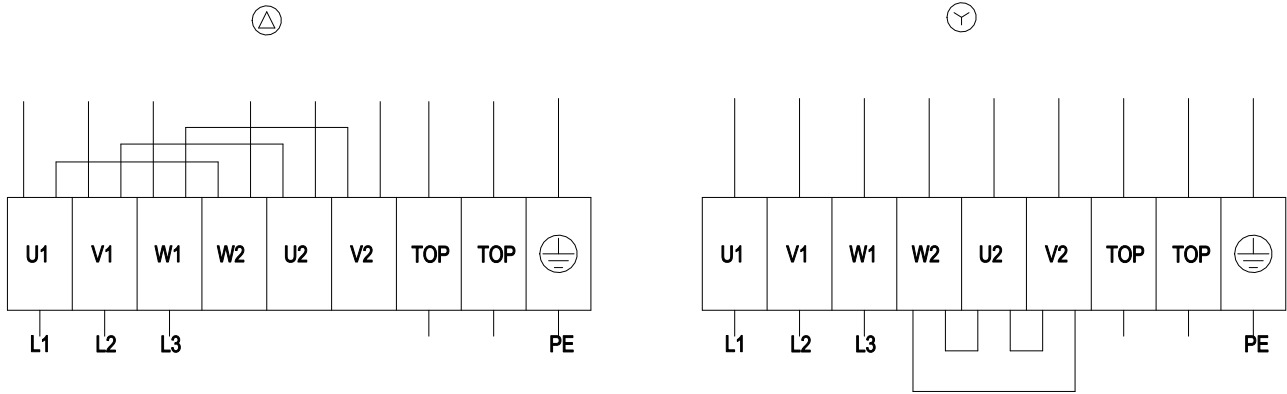

Δ	Delta connection	Y	Star connection	L1	= U1 = black
L2	= V1 = blue	L3	= W1 = brown	W2	yellow
U2	green	V2	white	TOP	2x gray
PE	green/yellow				



AC axial fan

sickle-shaped blades (S series)
with guard grille for short nozzle

Curves: Air performance 50 Hz

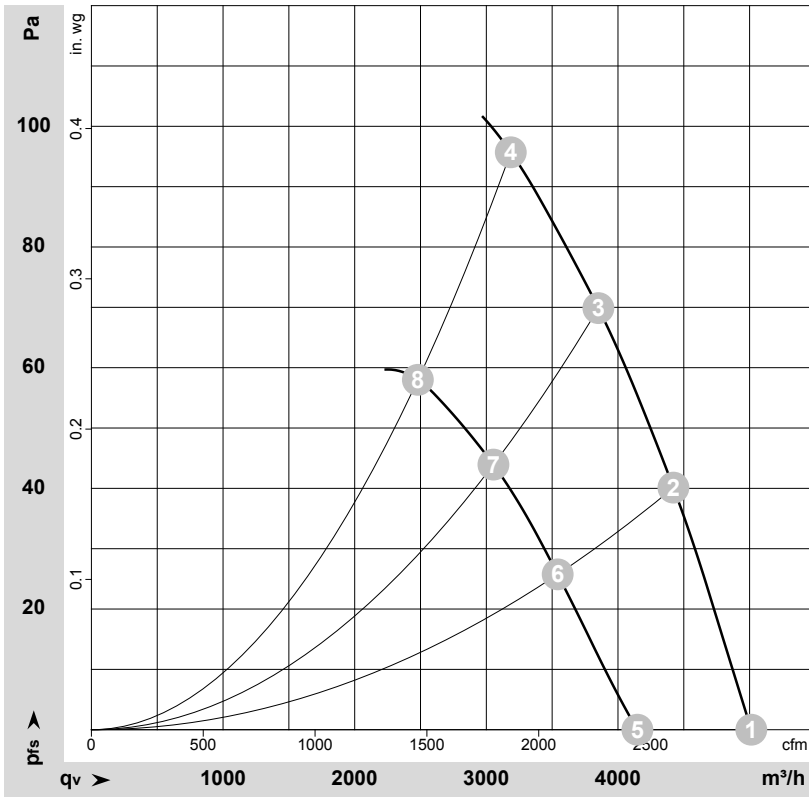

$\rho = 1.15 \text{ kg/m}^3 \pm 2 \%$

Measurement: LU-72485-1
Measurement: LU-143354-1

Air performance measured according to ISO 5801 installation category A. For detailed information on the measurement setup, contact ebm-papst. Intake sound level: Sound power level according to ISO 13347 / sound pressure level measured at 1 m distance from fan axis. The values given are valid under the specified measuring conditions and may vary due to conditions of installation. For deviations from the standard configuration, the parameters have to be checked on the installed unit.

Measured values

	Wired	U	f	n	P _e	I	q _v	P _{fs}	q _v	P _{fs}
		V	Hz	min ⁻¹	W	A	m ³ /h	Pa	cfm	in. wg
1	Δ	400	50	1390	207	0.46	5015	0	2950	0.00
2	Δ	400	50	1375	231	0.48	4420	40	2600	0.16
3	Δ	400	50	1360	245	0.49	3850	70	2265	0.28
4	Δ	400	50	1360	260	0.52	3185	95	1875	0.38
5	Y	400	50	1165	149	0.24	4150	0	2440	0.00
6	Y	400	50	1125	160	0.26	3540	26	2085	0.10
7	Y	400	50	1100	168	0.27	3055	44	1800	0.18
8	Y	400	50	1060	185	0.31	2480	58	1460	0.23

Wired = Wiring · U = Voltage · f = Frequency · n = Speed (rpm) · P_e = Power consumption · I = Current draw · q_v = Air flow · P_{fs} = Pressure increase



AC axial fan

sickle-shaped blades (S series)
with guard grille for short nozzle

Curves: Air performance 60 Hz

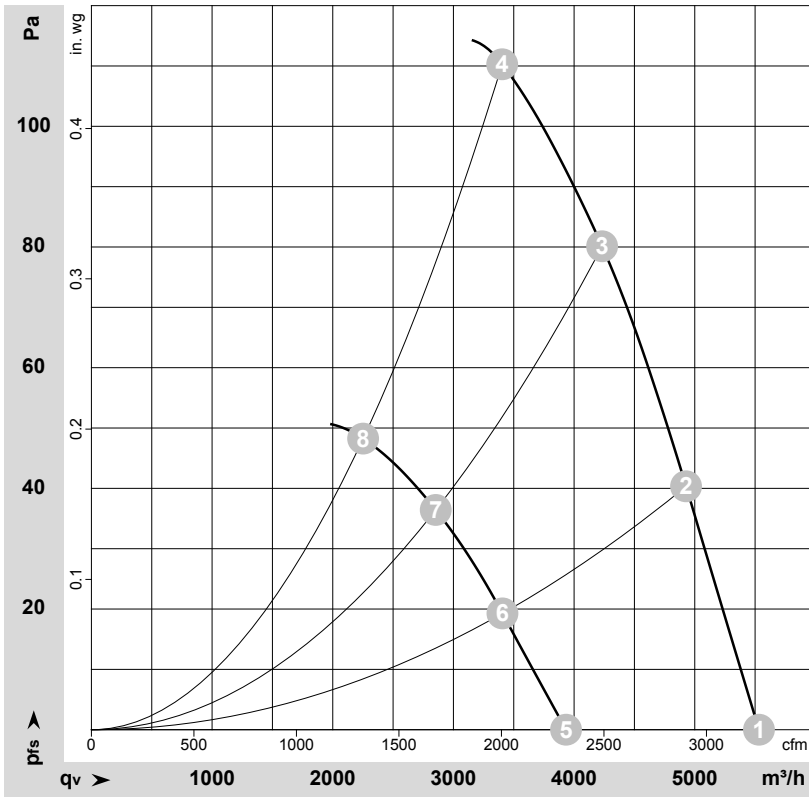

$\rho = 1.15 \text{ kg/m}^3 \pm 2 \%$

Measurement: LU-143361-1
Measurement: LU-143367-1

Air performance measured according to ISO 5801 installation category A. For detailed information on the measurement setup, contact ebm-papst. Intake sound level: Sound power level according to ISO 13347 / sound pressure level measured at 1 m distance from fan axis. The values given are valid under the specified measuring conditions and may vary due to conditions of installation. For deviations from the standard configuration, the parameters have to be checked on the installed unit.

Measured values

	Wired	U	f	n	P _e	I	q _v	P _{fs}	q _v	P _{fs}
		V	Hz	min ⁻¹	W	A	m ³ /h	Pa	cfm	in. wg
1	Δ	400	60	1545	298	0.52	5530	0	3255	0.00
2	Δ	400	60	1515	326	0.56	4930	40	2900	0.16
3	Δ	400	60	1490	346	0.59	4230	80	2490	0.32
4	Δ	400	60	1490	385	0.65	3405	110	2005	0.44
5	Y	400	60	1110	189	0.31	3935	0	2315	0.00
6	Y	400	60	1065	195	0.32	3405	19	2005	0.08
7	Y	400	60	1020	200	0.33	2855	37	1680	0.15
8	Y	400	60	970	220	0.37	2250	47	1325	0.19

Wired = Wiring · U = Voltage · f = Frequency · n = Speed (rpm) · P_e = Power consumption · I = Current draw · q_v = Air flow · P_{fs} = Pressure increase

