

AC axial fan

sickle-shaped blades (S series)
with guard grille for short nozzle

S4D400-AN14-16 ebmpapst Datasheet
sales@fansco.com
www.fansco.com

Limited partnership · Headquarters Mulfingen
Amtsgericht (court of registration) Stuttgart · HRA 590344

General partner Elektrobau Mulfingen GmbH · Headquarters Mulfingen
Amtsgericht (court of registration) Stuttgart · HRB 590142



Nominal data

Type	S4D400-AN14-16				
Motor	M4D094-FA				
Phase		3~	3~	3~	3~
Nominal voltage	VAC	400	400	400	400
Wiring		Δ	Y	Δ	Y
Frequency	Hz	50	50	60	60
Method of obtaining data		ml	ml	ml	ml
Valid for approval/standard		CE	CE	CE	CE
Speed (rpm)	min ⁻¹	1395	1200	1585	1185
Power consumption	W	330	240	470	310
Current draw	A	0.8	0.41	0.86	0.52
Max. back pressure	Pa	110	80	135	75
Max. back pressure	inH ₂ O	0.44	0.32	0.54	0.3
Min. ambient temperature	°C	-40	-40	-40	-40
Max. ambient temperature	°C	65	65	65	65
Starting current	A	3.3	1.1	3.1	1.05

ml = Max. load · me = Max. efficiency · fa = Free air · cs = Customer specification · ce = Customer equipment
Subject to change

Data according to ErP Directive

		Actual	Req. 2015			
01 Overall efficiency η_{es}	%	30.5	30.5	09 Power consumption P_e	kW	0.31
02 Measurement category		A		09 Air flow q_v	m ³ /h	3205
03 Efficiency category		Static		09 Pressure increase p_{fs}	Pa	104
04 Efficiency grade N		40	40	10 Speed (rpm) n	min ⁻¹	1400
05 Variable speed drive		No		11 Specific ratio*		1.00

Data obtained at optimum efficiency level.
The ErP data is determined using a motor-impeller combination in a standardized measurement setup.

* Specific ratio = $1 + p_s / 100\,000\text{ Pa}$

LU-161465



AC axial fan

sickle-shaped blades (S series)
with guard grille for short nozzle

Technical description

Weight	8.2 kg
Fan size	400 mm
Rotor surface	Painted black
Terminal box material	ABS plastic
Impeller material	PP plastic
Guard grille material	Steel, coated with black plastic (RAL 9005)
Number of blades	5
Airflow direction	"V"
Direction of rotation	Counterclockwise, viewed toward rotor
Degree of protection	IP54
Insulation class	"F"
Moisture (F) / Environmental (H) protection class	F4-1
Max. permitted ambient temp. for motor (transport/storage)	+80 °C
Min. permitted ambient temp. for motor (transport/storage)	-40 °C
Installation position	Shaft horizontal or rotor on bottom; rotor on top on request
Condensation drainage holes	On rotor side
Mode	S1
Motor bearing	Ball bearing
Touch current according to IEC 60990 (measuring circuit Fig. 4, TN system)	<= 3.5 mA
Electrical hookup	Via terminal box
Motor protection	Thermal overload protector (TOP) with basic insulation
With cable	Axial
Protection class	I (with customer connection of protective earth)
Conformity with standards	EN 60034-1 (2010); CE



AC axial fan

sickle-shaped blades (S series)
with guard grille for short nozzle

Product drawing

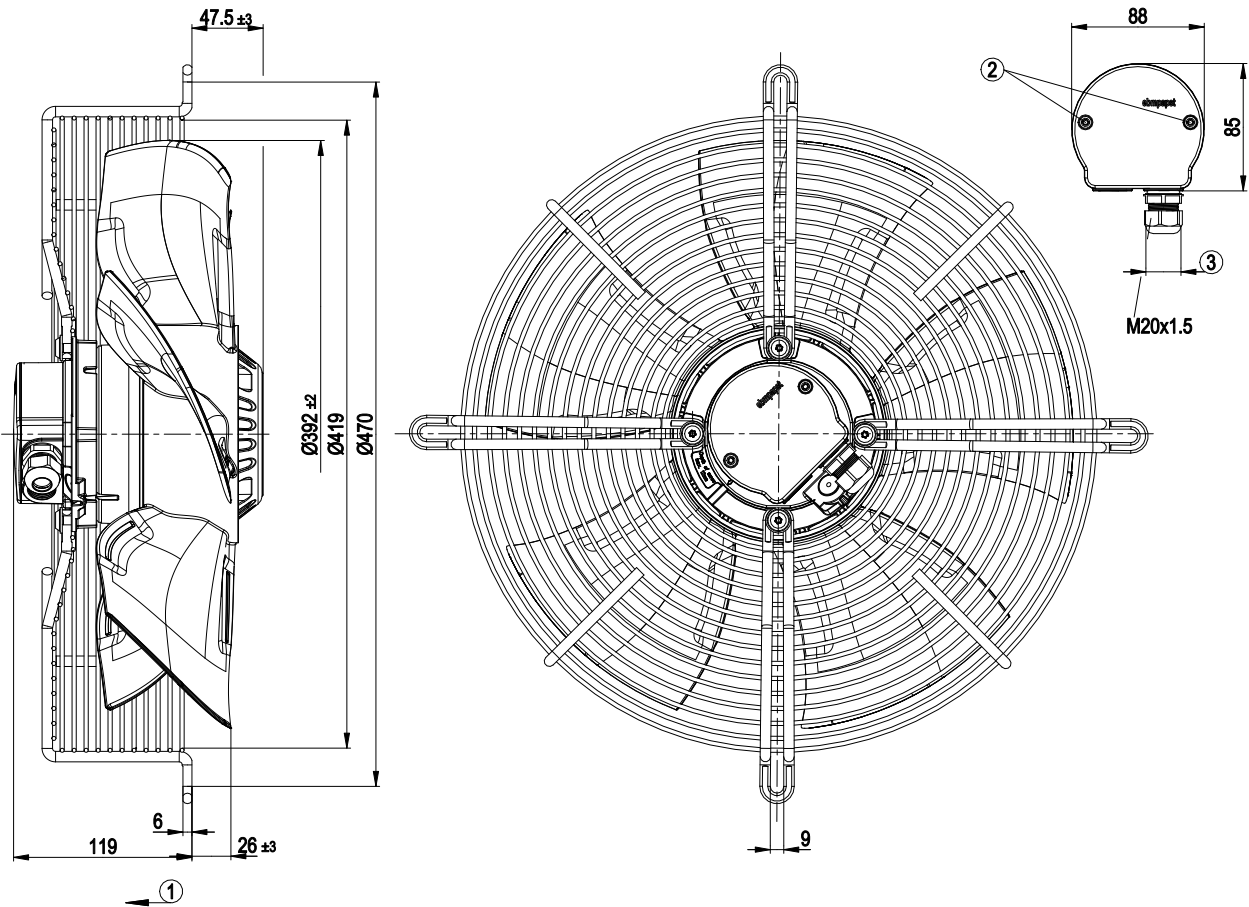

1	Direction of air flow "V"
2	Tightening torque 1.0 ± 0.15 Nm
3	Cable diameter: min. 6 mm, max. 12 mm; tightening torque 2 ± 0.2 Nm



AC axial fan

sickle-shaped blades (S series)
with guard grille for short nozzle

Connection diagram



Δ	Delta connection	Y	Star connection	L1	= U1 = black
L2	= V1 = blue	L3	= W1 = brown	W2	yellow
U2	green	V2	white	TOP	2x gray
PE	green/yellow				



AC axial fan

sickle-shaped blades (S series)
with guard grille for short nozzle

Curves: Air performance 50 Hz

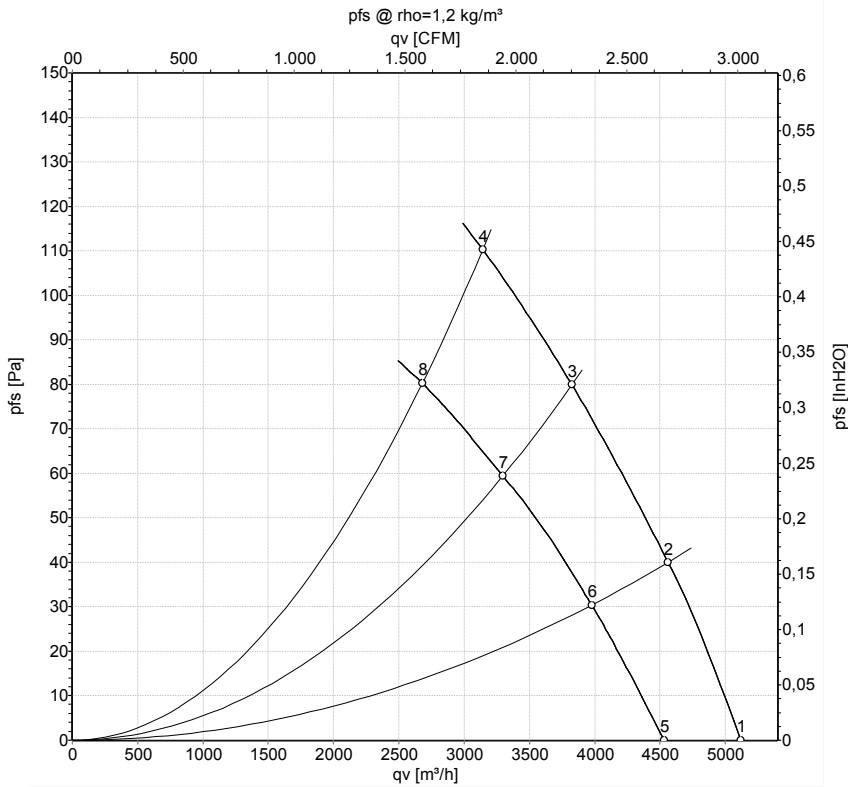

Measurement: LU-161465-1
Measurement: LU-161540-1

Air performance measured according to ISO 5801 installation category A. For detailed information on the measurement setup, contact ebm-papst. Intake sound level: Sound power level according to ISO 13347 / sound pressure level measured at 1 m distance from fan axis. The values given are valid under the specified measuring conditions and may vary due to conditions of installation. For deviations from the standard configuration, the parameters have to be checked on the installed unit.

Measured values

	Wired	U	f	n	P _e	I	qv	p _{fs}	qv	p _{fs}
		V	Hz	min ⁻¹	W	A	m ³ /h	Pa	CFM	inH2O
1	Δ	400	50	1420	272	0.73	5120	0	3010	0.00
2	Δ	400	50	1415	290	0.74	4560	40	2685	0.16
3	Δ	400	50	1405	305	0.75	3825	80	2250	0.32
4	Δ	400	50	1395	330	0.80	3145	110	1850	0.44
5	Y	400	50	1255	204	0.34	4530	0	2665	0.00
6	Y	400	50	1230	219	0.36	3975	31	2340	0.12
7	Y	400	50	1215	229	0.38	3300	59	1940	0.24
8	Y	400	50	1200	240	0.41	2680	80	1575	0.32

Wired = Wiring · U = Power supply · f = Frequency · n = Speed (rpm) · P_e = Power consumption · I = Current draw · qv = Air flow · p_{fs} = Pressure increase



AC axial fan

sickle-shaped blades (S series)
with guard grille for short nozzle

Curves: Air performance 60 Hz

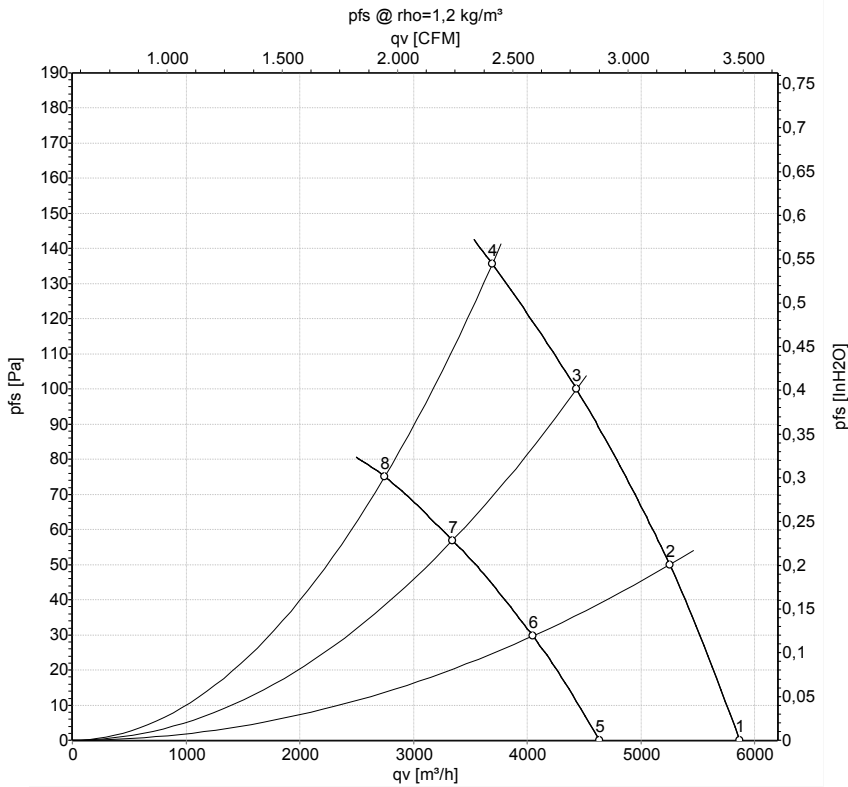

Measurement: LU-161538-1
Measurement: LU-161541-1

Air performance measured according to ISO 5801 installation category A. For detailed information on the measurement setup, contact ebm-papst. Intake sound level: Sound power level according to ISO 13347 / sound pressure level measured at 1 m distance from fan axis. The values given are valid under the specified measuring conditions and may vary due to conditions of installation. For deviations from the standard configuration, the parameters have to be checked on the installed unit.

Measured values

	Wired	U	f	n	P _e	I	qv	p _{fs}	qv	p _{fs}
		V	Hz	min ⁻¹	W	A	m ³ /h	Pa	CFM	inH2O
1	Δ	400	60	1630	396	0.74	5870	0	3455	0.00
2	Δ	400	60	1615	427	0.78	5255	50	3090	0.20
3	Δ	400	60	1600	447	0.80	4430	100	2610	0.40
4	Δ	400	60	1585	470	0.86	3690	135	2175	0.54
5	Y	400	60	1280	289	0.48	4635	0	2725	0.00
6	Y	400	60	1240	300	0.50	4050	30	2385	0.12
7	Y	400	60	1210	308	0.51	3345	57	1970	0.23
8	Y	400	60	1185	310	0.52	2745	75	1615	0.30

Wired = Wiring · U = Power supply · f = Frequency · n = Speed (rpm) · P_e = Power consumption · I = Current draw · qv = Air flow · p_{fs} = Pressure increase

