

AC axial fan

straight blades (A series), single inlet
with guard grille for full nozzle

S4D350-BA06-08 ebmpapst Datasheet

sales@fansco.com

www.fansco.com

Nominal data

Type	S4D350-BA06-08				
Motor	M4D068-EC				
Phase		3~	3~	3~	3~
Nominal voltage	VAC	230	230	400	400
Connection		Δ	Δ	Y	Y
Frequency	Hz	50	60	50	60
Type of data definition		fa	fa	fa	fa
Valid for approval / standard		-	-	-	-
Speed	min ⁻¹	1420	1620	1420	1620
Power input	W	145	190	145	190
Current draw	A	0.68	0.62	0.39	0.36
Max. back pressure	Pa	150	150	150	150
Min. ambient temperature	°C	-25	-25	-25	-25
Max. ambient temperature	°C	50	50	50	50

ml = Max. load · me = Max. efficiency · fa = Running at free air · cs = Customer specs · cu = Customer unit
Subject to alterations

Data according to ErP directive

Installation category	A
Efficiency category	Static
Variable speed drive	No
Specific ratio*	1.00

* Specific ratio = $1 + p_b / 100\,000\text{ Pa}$

		Actual	Request 2013	Request 2015
Overall efficiency η_{es}	%	28.5	24.5	28.5
Efficiency grade N		40	36	40
Power input P_e	kW	0.15		
Air flow q_v	m ³ /h	2015		
Pressure increase p_{fs}	Pa	75		
Speed n	min ⁻¹	1390		

Data definition with optimum efficiency. LU-64797
The ErP data is determined using a motor-impeller combination in a standardised measurement configuration.



AC axial fan

straight blades (A series), single inlet
with guard grille for full nozzle

Technical features

Mass	4.2 kg
Size	350 mm
Surface of rotor	Coated in black
Material of terminal box	ABS plastic
Material of blades	Sheet steel, coated in black
Material of guard grille	Steel, coated in black plastic (RAL9005)
Number of blades	5
Direction of air flow	"A"
Direction of rotation	Clockwise, seen on rotor
Type of protection	IP 44; Depending on installation and position as per EN 60034-5
Insulation class	"B"
Humidity class	F2-2
Max. permissible ambient motor temp. (transp./ storage)	+ 80 °C
Min. permissible ambient motor temp. (transp./storage)	- 40 °C
Mounting position	Shaft horizontal or rotor on bottom; rotor on top on request
Condensate discharge holes	Rotor-side
Operation mode	S1
Motor bearing	Ball bearing
Touch current acc. IEC 60990 (measuring network Fig. 4, TN system)	< 0.75 mA
Electrical leads	Via terminal box
Cable exit	Axial
Protection class	I (if protective earth is connected by customer)
Product conforming to standard	EN 60335-1, motor does not have factory-installed overheating protection
Approval	CCC



AC axial fan

straight blades (A series), single inlet
with guard grille for full nozzle

Product drawing

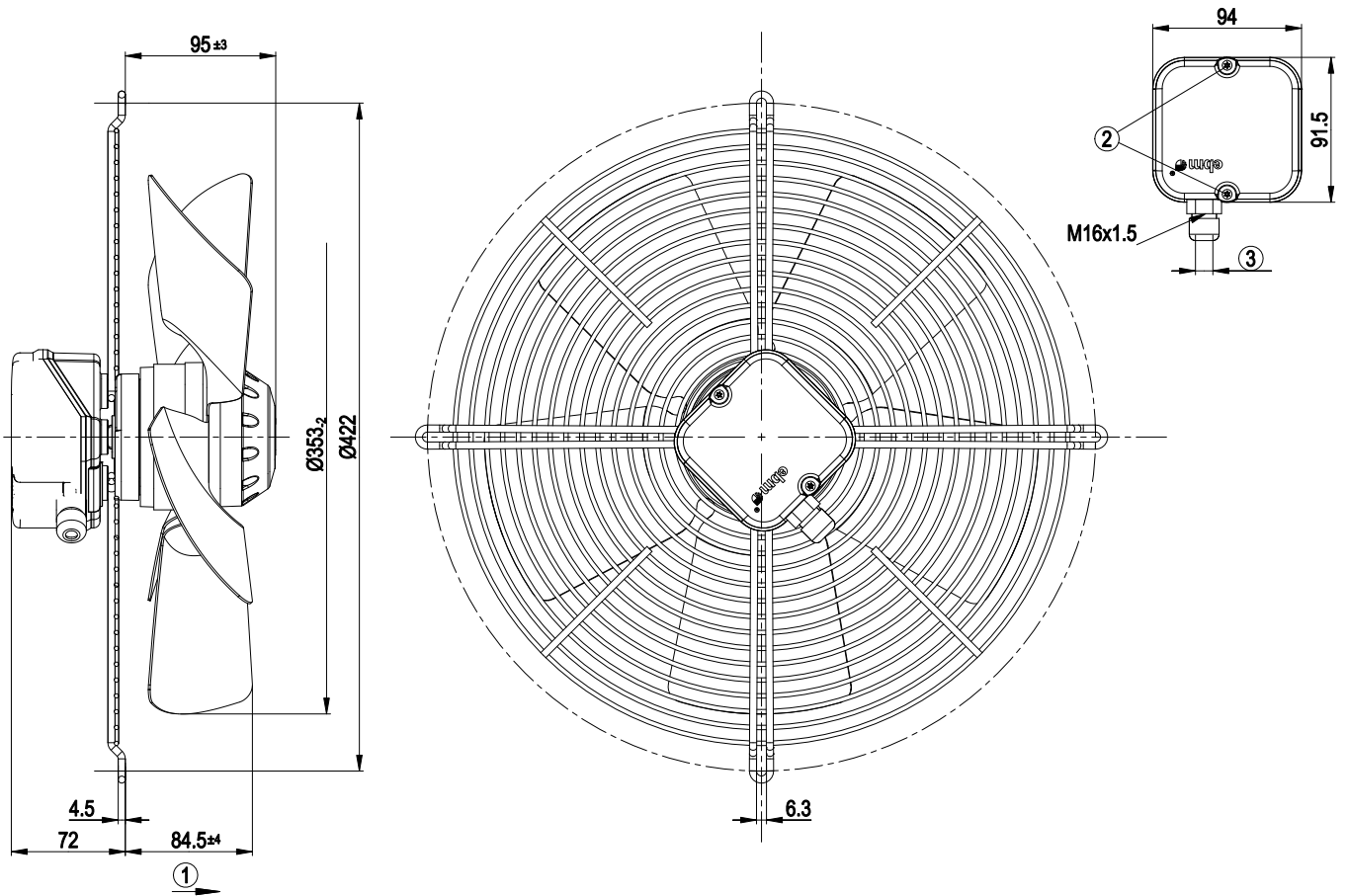

1	Direction of air flow "A"
2	Tightening torque 0.5 ± 0.1 Nm
3	Cable diameter max. 7.5 mm, tightening torque 1.3 ± 0.2 Nm



AC axial fan

straight blades (A series), single inlet
with guard grille for full nozzle

Connection screen

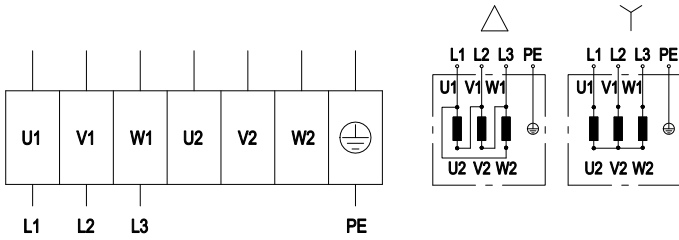

	Three-phase motor	Y	Star connection	Δ	Delta connection
L1	= U1 = blue	L2	= V1 = black	L3	= W1 = brown
U2	= white	V2	= green	W2	= yellow
PE	PE (green/yellow)				



AC axial fan

straight blades (A series), single inlet
with guard grille for full nozzle

Charts: Air flow 50 Hz

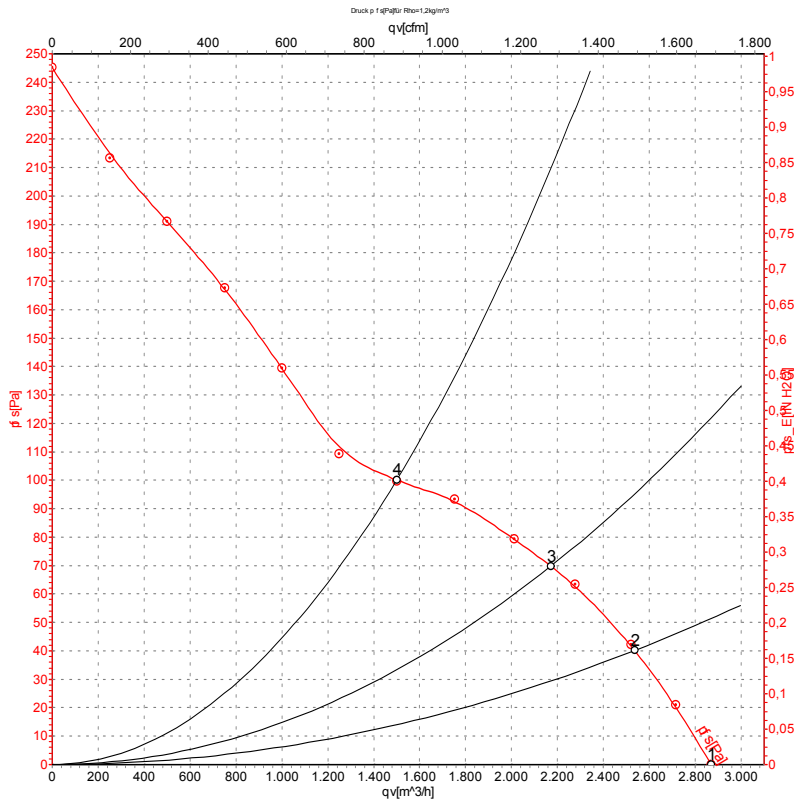

Measurement: LU-64797

Air performance measured as per ISO 5801 Installation category A. For detailed information on the measuring set-up, please contact ebm-papst. Suction-side noise levels: LwA measured as per ISO 13347 / LpA measured with 1m distance to fan axis. The values given are valid under the measuring conditions mentioned above and may vary according to the actual installation situation. With any deviation from the standard set-up, the specific values have to be checked and reviewed with the unit installed.

Measured values

	U	f	n	P _e	I	qv	p _{fs}
	V	Hz	min ⁻¹	W	A	m ³ /h	Pa
1	400	50	1420	128	0.39	2870	0
2	400	50	1405	141	0.40	2535	40
3	400	50	1395	150	0.41	2170	70
4	400	50	1385	158	0.41	1500	100

U = Supply voltage · f = Frequency · n = Speed · P_e = Power input · I = Current draw · qv = Air flow · p_{fs} = Pressure increase



AC axial fan

straight blades (A series), single inlet
with guard grille for full nozzle

Charts: Air flow 60 Hz

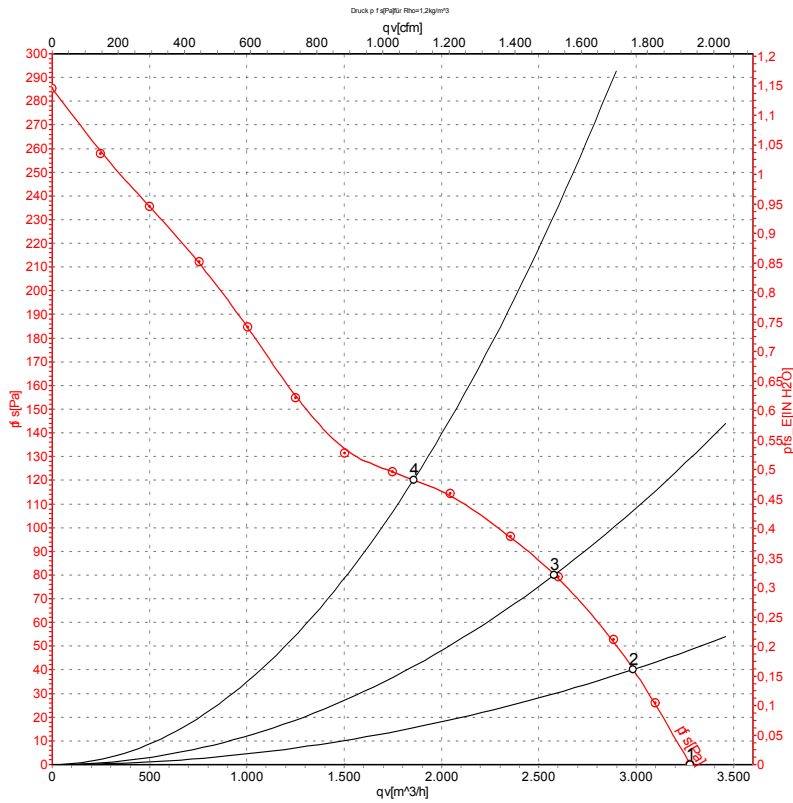

Measurement: LU-64798

Air performance measured as per ISO 5801 Installation category A. For detailed information on the measuring set-up, please contact ebm-papst. Suction-side noise levels: LwA measured as per ISO 13347 / LpA measured with 1m distance to fan axis. The values given are valid under the measuring conditions mentioned above and may vary according to the actual installation situation. With any deviation from the standard set-up, the specific values have to be checked and reviewed with the unit installed.

Measured values

	U	f	n	P _e	I	qv	P _{fs}
	V	Hz	min ⁻¹	W	A	m ³ /h	Pa
1	400	60	1620	169	0.36	3280	0
2	400	60	1605	185	0.36	2985	40
3	400	60	1580	202	0.38	2580	80
4	400	60	1560	217	0.39	1855	120

U = Supply voltage · f = Frequency · n = Speed · P_e = Power input · I = Current draw · qv = Air flow · P_{fs} = Pressure increase

