

AC axial fan

straight blades (A series)

with guard grille for full nozzle

S4D350-BA06-02 ebmpapst Datasheet FansCo

sales@fansco.com

www.fansco.com

Nominal data

Type	S4D350-BA06-02				
Motor	M4D068-EC				
Phase		3~	3~	3~	3~
Nominal voltage	VAC	230	230	400	400
Connection		Δ	Δ	Y	Y
Frequency	Hz	50	60	50	60
Type of data definition		fa	fa	fa	fa
Valid for approval / standard		-	-	-	-
Speed	min ⁻¹	1420	1620	1420	1620
Power input	W	145	190	145	190
Current draw	A	0.68	0.62	0.39	0.36
Max. back pressure	Pa	150	150	150	150
Min. ambient temperature	°C	-25	-25	-25	-25
Max. ambient temperature	°C	50	50	50	50

ml = Max. load · me = Max. efficiency · fa = Running at free air · cs = Customer specs · cu = Customer unit
Subject to alterations

Data according to ErP directive

Installation category	A	Overall efficiency η_{es}	%	Actual 28.5	Request 2013 24.5	Request 2015 28.5
Efficiency category	Static	Efficiency grade N		40	36	40
Variable speed drive	No	Power input P_e	kW	0.15		
Specific ratio [*]	1.00	Air flow q_v	m ³ /h	2015		
		Pressure increase p_{fs}	Pa	75		
		Speed n	min ⁻¹	1390		

^{*} Specific ratio = $1 + p_b / 100\,000\text{ Pa}$

Data definition with optimum efficiency. LU-64797
The ErP data is determined using a motor-impeller combination in a standardised measurement configuration.



AC axial fan

straight blades (A series)
with guard grille for full nozzle

Technical features

Mass	4 kg
Size	350 mm
Surface of rotor	Coated in black
Material of blades	Sheet steel, coated in black
Material of guard grille	Steel, coated in black plastic (RAL9005)
Number of blades	5
Direction of air flow	"A"
Direction of rotation	Clockwise, seen on rotor
Type of protection	IP 44; Depending on installation and position as per EN 60034-5
Insulation class	"B"
Humidity class	F1-2
Max. permissible ambient motor temp. (transp./ storage)	+ 80 °C
Min. permissible ambient motor temp. (transp./storage)	- 40 °C
Mounting position	Shaft horizontal or rotor on bottom; rotor on top on request
Condensate discharge holes	Rotor-side
Operation mode	S1
Motor bearing	Ball bearing
Touch current acc. IEC 60990 (measuring network Fig. 4, TN system)	< 0.75 mA
Cable exit	Lateral
Protection class	I (if protective earth is connected by customer)
Product conforming to standard	EN 60335-1
Approval	EAC



AC axial fan

straight blades (A series)

with guard grille for full nozzle

Product drawing

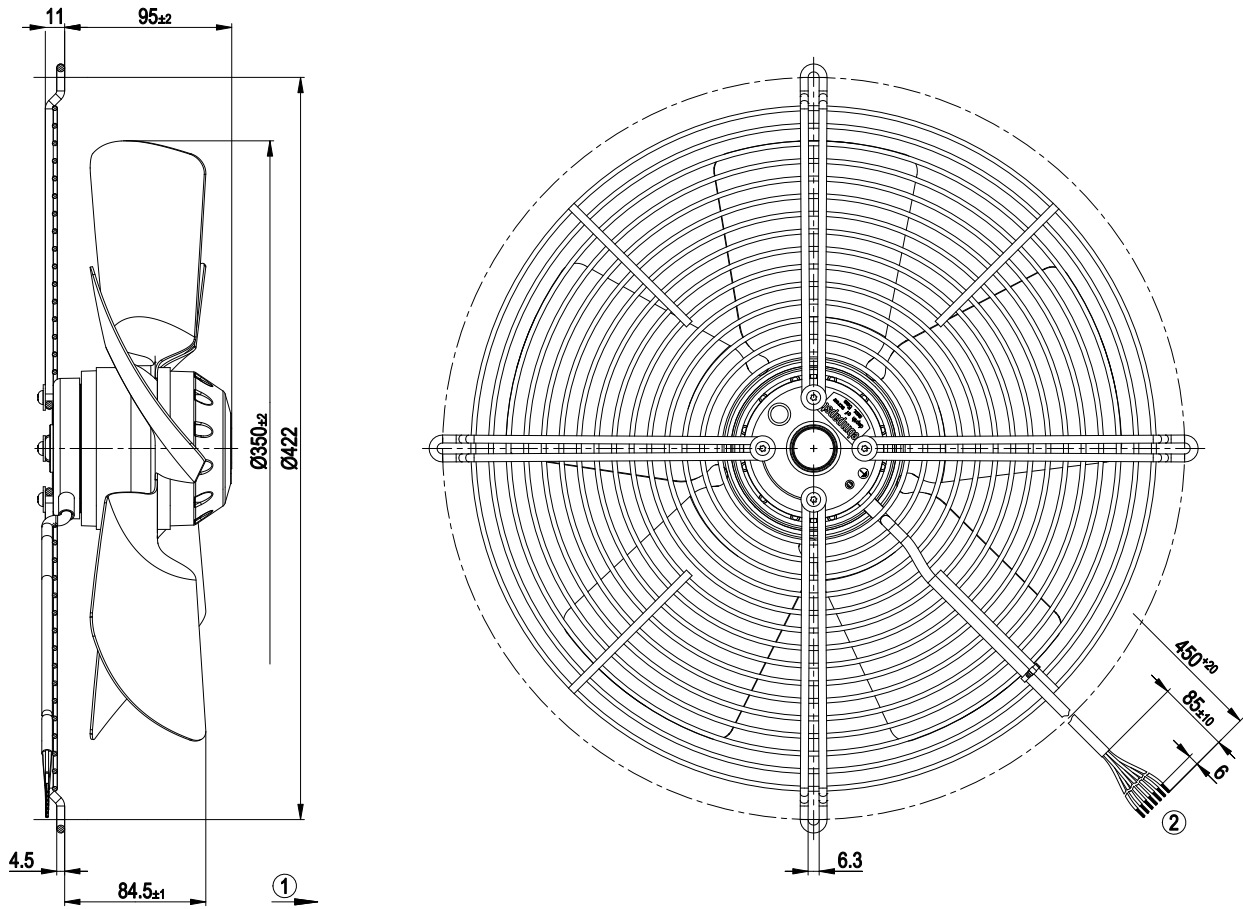

- | | |
|---|---|
| 1 | Direction of air flow "A" |
| 2 | Connection line PVC 7G 0.5 mm ² , 7x lead tips crimped |



AC axial fan

straight blades (A series)
with guard grille for full nozzle

Connection screen

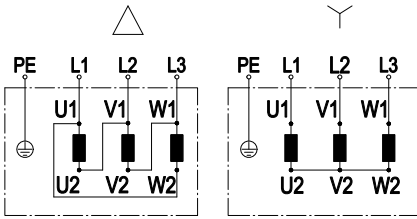

Change direction of rotation by reversing two phases

	Three-phase motor	Δ	Delta connection	Y	Star connection
L1	= U1 = black	L2	= V1 = blue	L3	= W1 = brown
U2	green	V2	white	W2	yellow
PE	green/yellow				



AC axial fan

straight blades (A series)
with guard grille for full nozzle

Charts: Air flow 50 Hz

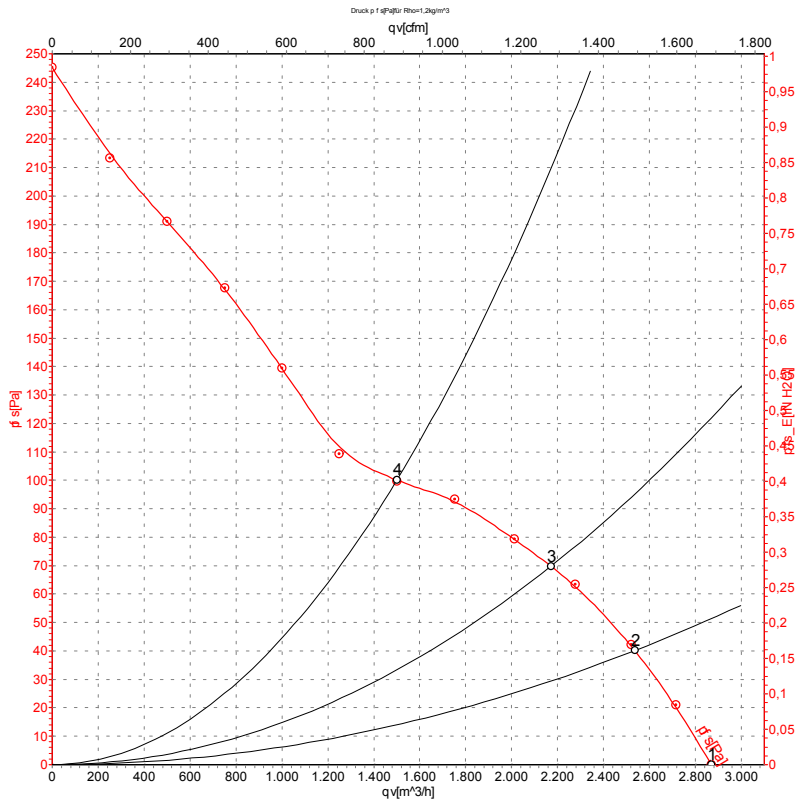

Air performance measured as per ISO 5801 Installation category A. For detailed information on the measuring set-up, please contact ebm-papst. Suction-side noise levels: LwA measured as per ISO 13347 / LpA measured with 1m distance to fan axis. The values given are valid under the measuring conditions mentioned above and may vary according to the actual installation situation. With any deviation from the standard set-up, the specific values have to be checked and reviewed with the unit installed.

Measured values

	U	f	n	P _e	I	qv	p _{fs}
	V	Hz	min ⁻¹	W	A	m ³ /h	Pa
1	400	50	1420	128	0.39	2870	0
2	400	50	1405	141	0.40	2535	40
3	400	50	1395	150	0.41	2170	70
4	400	50	1385	158	0.41	1500	100

U = Supply voltage · f = Frequency · n = Speed · P_e = Power input · I = Current draw · qv = Air flow · p_{fs} = Pressure increase



AC axial fan

straight blades (A series)
with guard grille for full nozzle

Charts: Air flow 60 Hz

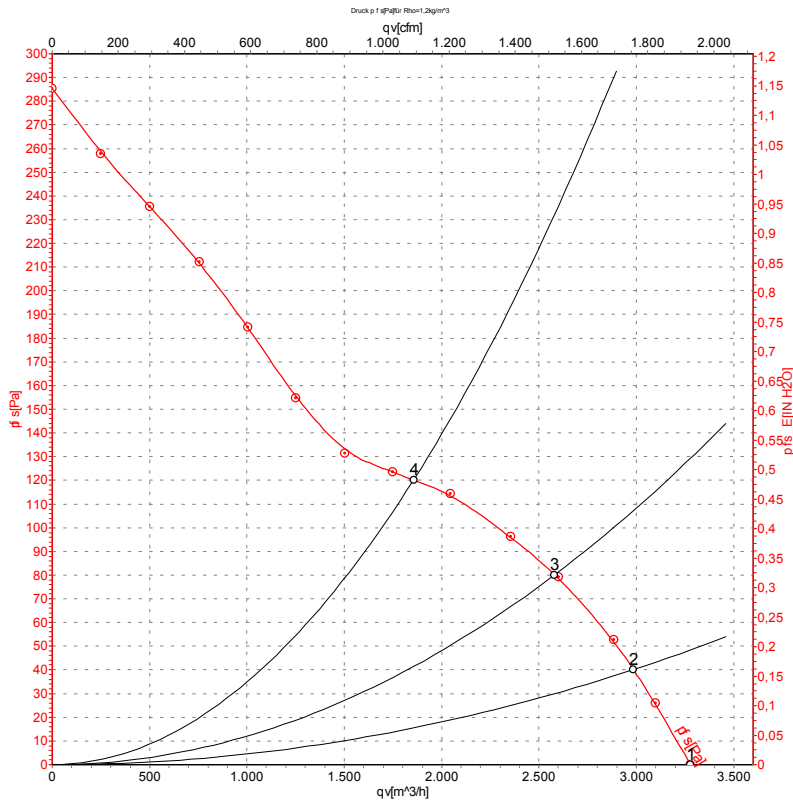

Air performance measured as per ISO 5801 Installation category A. For detailed information on the measuring set-up, please contact ebm-papst. Suction-side noise levels: L_{wA} measured as per ISO 13347 / L_{pA} measured with 1m distance to fan axis. The values given are valid under the measuring conditions mentioned above and may vary according to the actual installation situation. With any deviation from the standard set-up, the specific values have to be checked and reviewed with the unit installed.

Measured values

	U	f	n	P _e	I	qv	p _{fs}
	V	Hz	min ⁻¹	W	A	m³/h	Pa
1	400	60	1620	169	0.36	3280	0
2	400	60	1605	185	0.36	2985	40
3	400	60	1580	202	0.38	2580	80
4	400	60	1560	217	0.39	1855	120

U = Supply voltage · f = Frequency · n = Speed · P_e = Power input · I = Current draw · qv = Air flow · p_{fs} = Pressure increase

