

S4D350-AP08-45 ebmpapst Datasheet

sales@fansco.com

www.fansco.com



## Nominal data

Type	S4D350-AP08-45				
Motor	M4D074-DF				
Phase		3~	3~	3~	3~
Nominal voltage	VAC	230	230	400	400
Connection		$\Delta$	$\Delta$	Y	Y
Frequency	Hz	50	60	50	60
Type of data definition		fa	fa	fa	fa
Valid for approval / standard		CE	CE	CE	CE
Speed	min <sup>-1</sup>	1410	1600	1410	1600
Power input	W	130	180	130	180
Current draw	A	0.61	0.59	0.35	0.34
Max. back pressure	Pa	90	90	90	90
Min. ambient temperature	°C	-25	-25	-25	-25
Max. ambient temperature	°C	70	60	70	60

ml = max. load · me = max. efficiency · fa = running at free air · cs = customer specs · cu = customer unit  
Subject to alterations

## Data according to ErP directive

Installation category	A	Overall efficiency $\eta_{es}$	Actual	Request 2013	Request 2015
Efficiency category	Static	Efficiency grade N	30.7	24.5	28.5
Variable speed drive	No	Power input $P_e$	42.2	36	40
Specific ratio <sup>*</sup>	1.00	Air flow $q_v$	0.15		
		Pressure increase $p_{fs}$	2110		
		Speed n	80		
			min <sup>-1</sup>	1385	

<sup>\*</sup> Specific ratio =  $1 + p_b / 100\,000\text{ Pa}$

Data established at point of optimum efficiency



# AC axial fan

sickled blades (S series)  
with guard grille for short nozzle

## Technical features

<b>Mass</b>	5.21 kg
<b>Size</b>	350 mm
<b>Surface of rotor</b>	Coated in black
<b>Material of terminal box</b>	ABS plastic
<b>Material of blades</b>	Sheet steel, coated in black
<b>Material of guard grille</b>	Steel, coated in black plastic (RAL9005)
<b>Number of blades</b>	5
<b>Direction of air flow</b>	"V"
<b>Direction of rotation</b>	Counter-clockwise, seen on rotor
<b>Type of protection</b>	IP 44; Depending on installation and position as per EN 60034-5
<b>Insulation class</b>	"F"
<b>Humidity class</b>	F1-2
<b>Max. permissible ambient motor temp. (transp./ storage)</b>	+ 80 °C
<b>Min. permissible ambient motor temp. (transp./storage)</b>	- 40 °C
<b>Mounting position</b>	Shaft horizontal or rotor on bottom; rotor on top on request
<b>Condensate discharge holes</b>	Rotor-side
<b>Operation mode</b>	S1
<b>Motor bearing</b>	Ball bearing
<b>Touch current acc. IEC 60990 (measuring network Fig. 4, TN system)</b>	< 0.75 mA
<b>Electrical leads</b>	Via terminal box
<b>Cable exit</b>	Axial
<b>Protection class</b>	I (if protective earth is connected by customer)
<b>Product conforming to standard</b>	EN 60335-1



S4D350-AP08-45

# AC axial fan

sickled blades (S series)  
with guard grille for short nozzle

## Product drawing

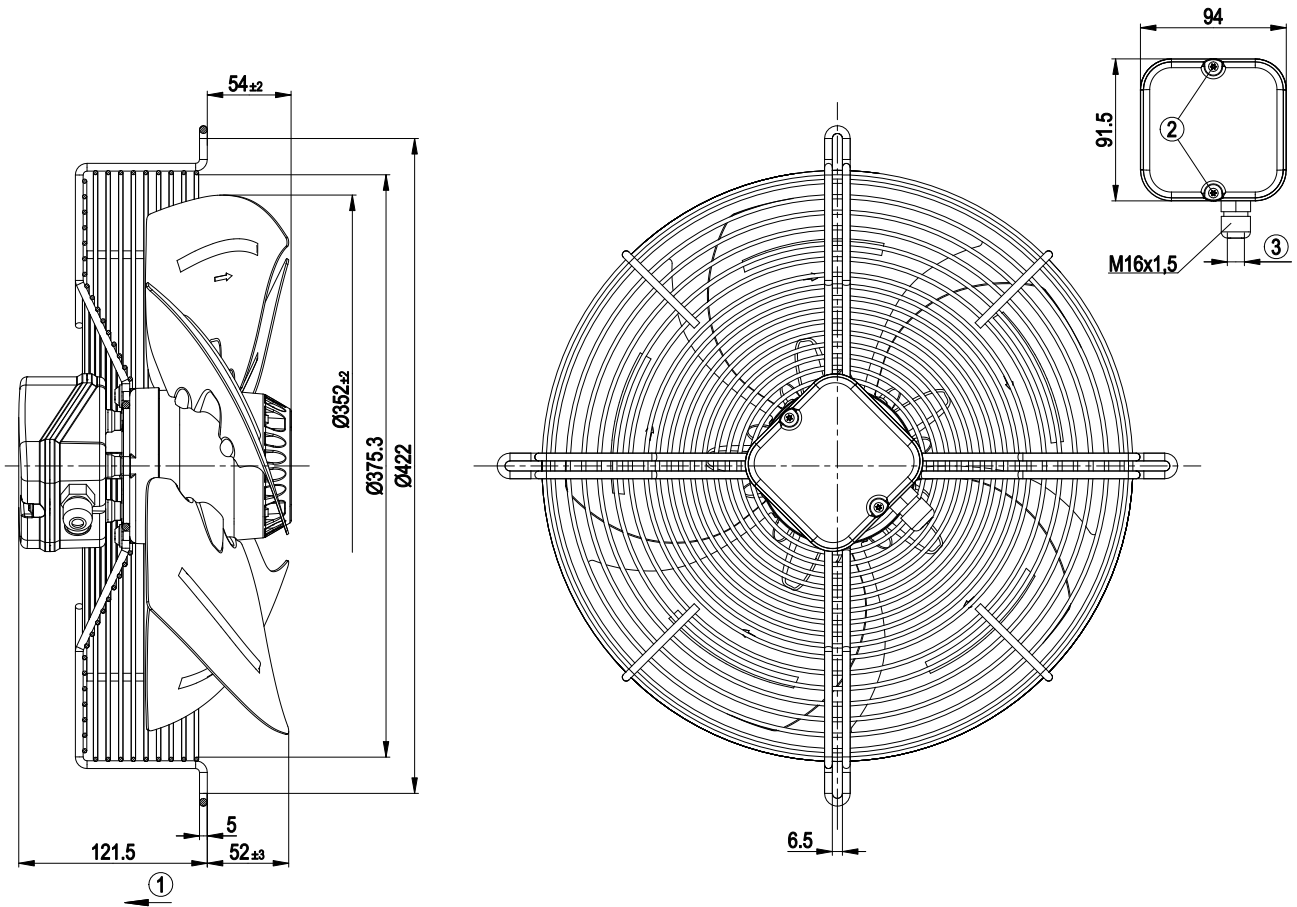

1	Direction of air flow "V"
2	Tightening torque 0.5±0.1 Nm
3	Cable diameter: min. 6 mm, max. 12 mm; tightening torque: 1.3±0.2 Nm



# AC axial fan

sickled blades (S series)  
with guard grille for short nozzle

## Connection screen

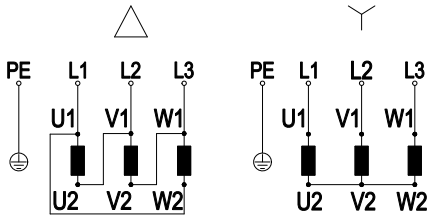

Note: Direction of rotation changes when two phases are reversed

Δ	Delta connection	Y	Star connection	L1	black
L2	blue	L3	brown	U1	black
V1	blue	W1	brown	U2	green
V2	white	W2	yellow	PE	green/yellow



# AC axial fan

sickled blades (S series)  
with guard grille for short nozzle

## Charts: Air flow 50 Hz

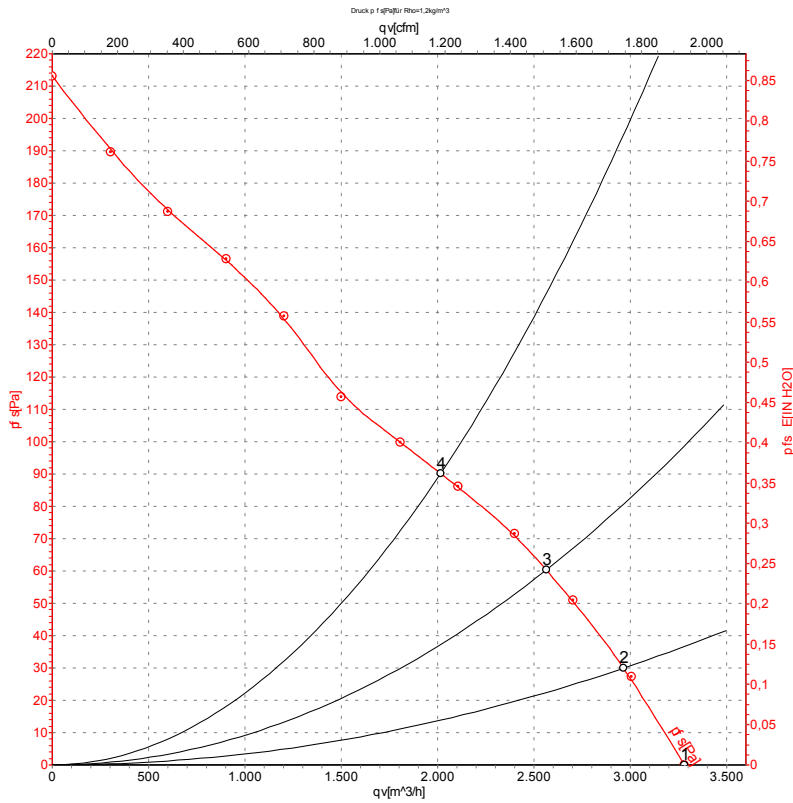

Measurement: LU-122615

Air performance measured as per ISO 5801 Installation category A. For detailed information on the measuring set-up, please contact ebm-papst. Suction-side noise levels: LwA measured as per ISO 13347 / LpA measured with 1m distance to fan axis. The values given are valid under the measuring conditions mentioned above and may vary according to the actual installation situation. With any deviation from the standard set-up, the specific values have to be checked and reviewed with the unit installed.

## Measured values

	Conn.	U	f	n	Pe	I	qv	pfs
		V	Hz	min <sup>-1</sup>	W	A	m <sup>3</sup> /h	Pa
1	Y	400	50	1410	130	0.35	3280	0
2	Y	400	50	1395	145	0.35	2965	30
3	Y	400	50	1380	158	0.36	2565	60
4	Y	400	50	1355	179	0.38	2015	90

Conn. = Connection · U = Supply voltage · f = Frequency · n = Speed · Pe = Power input · I = Current draw · qv = Air flow · pfs = Pressure increase



# AC axial fan

sickled blades (S series)  
with guard grille for short nozzle

## Charts: Air flow 60 Hz

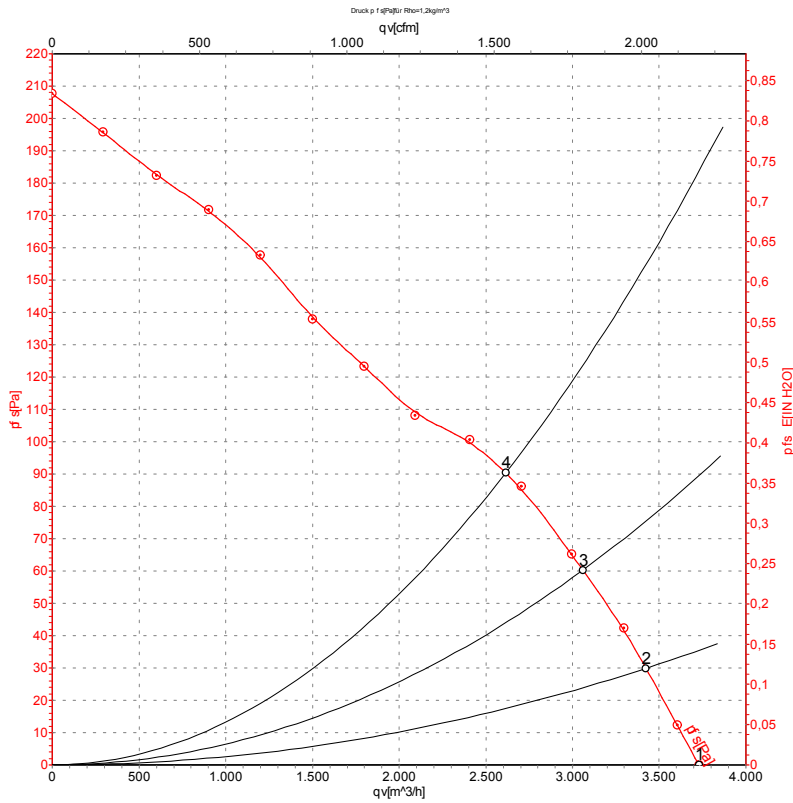

Measurement: LU-122616

Air performance measured as per ISO 5801 Installation category A. For detailed information on the measuring set-up, please contact ebm-papst. Suction-side noise levels: L<sub>wA</sub> measured as per ISO 13347 / L<sub>pA</sub> measured with 1m distance to fan axis. The values given are valid under the measuring conditions mentioned above and may vary according to the actual installation situation. With any deviation from the standard set-up, the specific values have to be checked and reviewed with the unit installed.

## Measured values

	Conn.	U	f	n	P <sub>e</sub>	I	qv	p <sub>fs</sub>
		V	Hz	min <sup>-1</sup>	W	A	m <sup>3</sup> /h	Pa
1	Y	400	60	1600	180	0.34	3730	0
2	Y	400	60	1585	196	0.35	3425	30
3	Y	400	60	1555	214	0.37	3060	60
4	Y	400	60	1525	232	0.40	2615	90

Conn. = Connection · U = Supply voltage · f = Frequency · n = Speed · P<sub>e</sub> = Power input · I = Current draw · qv = Air flow · p<sub>fs</sub> = Pressure increase

