

AC axial fan

sickle-shaped blades (S series)
with guard grille for short nozzle

S4D350-AN24-84 ebmpapst Datasheet
sales@fansco.com
www.fansco.com

Limited partnership · Headquarters Mulfingen
Amtsgericht (court of registration) Stuttgart · HRA 590344

General partner Elektrobau Mulfingen GmbH · Headquarters Mulfingen
Amtsgericht (court of registration) Stuttgart · HRB 590142



Nominal data

Type	S4D350-AN24-84				
Motor	M4D074-DF				
Phase		3~	3~	3~	3~
Nominal voltage	VAC	400	400	480	480
Wiring		Δ	Y	Δ	Y
Frequency	Hz	50	50	60	60
Method of obtaining data		ml	ml	ml	ml
Valid for approval/standard		CE	CE	CE	CE
Speed (rpm)	min ⁻¹	1370	1080	1590	1190
Power consumption	W	170	115	260	175
Current draw	A	0.4	0.20	0.44	0.25
Max. back pressure	Pa	90	55	125	70
Max. back pressure	inH ₂ O	0.36	0.22	0.5	0.28
Min. ambient temperature	°C	-25	-25	-25	-25
Max. ambient temperature	°C	65	65	50	50
Starting current	A	1.1	0.35	1.25	0.4

ml = Max. load · me = Max. efficiency · fa = Free air · cs = Customer specification · ce = Customer equipment
Subject to change

Data according to ErP Directive

		Actual	Req. 2015		
01 Overall efficiency η_{es}	%	28.6	28.6	09 Power consumption P_e	kW 0.16
02 Measurement category	A			09 Air flow q_v	m ³ /h 2250
03 Efficiency category	Static			09 Pressure increase p_{fs}	Pa 74
04 Efficiency grade N	40	40		10 Speed (rpm) n	min ⁻¹ 1375
05 Variable speed drive	No			11 Specific ratio*	1.00

Data obtained at optimum efficiency level.
The ErP data is determined using a motor-impeller combination in a standardized measurement setup.

* Specific ratio = $1 + p_s / 100\,000\text{ Pa}$

LU-140791



AC axial fan

sickle-shaped blades (S series)
with guard grille for short nozzle

Technical description

Weight	4.8 kg
Fan size	350 mm
Rotor surface	Painted black
Blade material	PP plastic
Number of blades	5
Airflow direction	"V"
Direction of rotation	Counterclockwise, viewed toward rotor
Degree of protection	IP44; installation- and position-dependent as per EN 60034-5
Insulation class	"F"
Moisture (F) / Environmental (H) protection class	F2-2
Max. permitted ambient temp. for motor (transport/storage)	+ 80 °C
Min. permitted ambient temp. for motor (transport/storage)	- 40 °C
Installation position	Shaft horizontal or rotor on bottom; rotor on top on request
Condensation drainage holes	On rotor side
Mode	S1
Motor bearing	Ball bearing
Touch current according to IEC 60990 (measuring circuit Fig. 4, TN system)	< 0.75 mA
Motor protection	Thermal overload protector (TOP) with basic insulation
With cable	Variable
Protection class	I (with customer connection of protective earth)
Conformity with standards	EN 60335-1; CE



AC axial fan

sickle-shaped blades (S series)
with guard grille for short nozzle

Product drawing

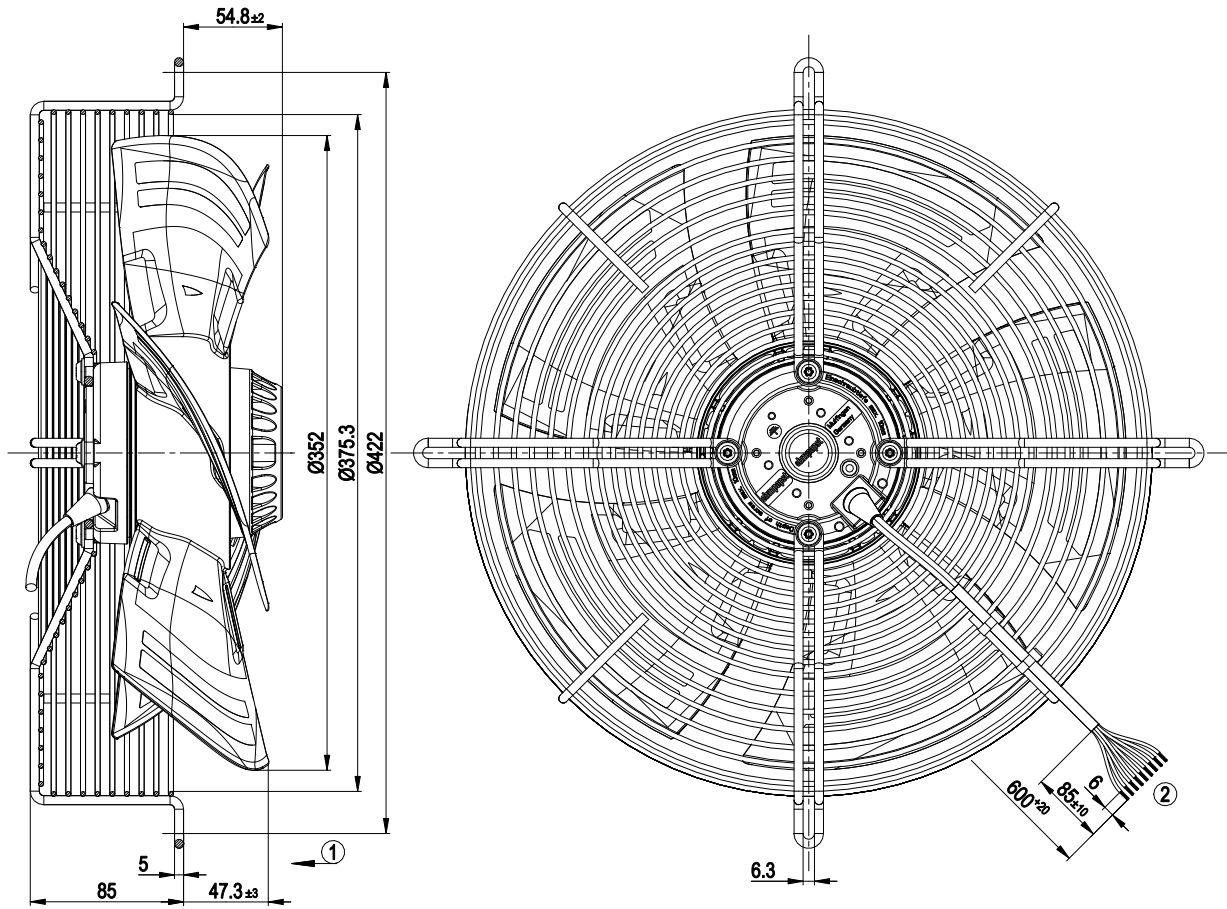

- 1 Direction of air flow "V"
- 2 Cable silicone 9G 0.5 mm², 9x crimped splices



AC axial fan

sickle-shaped blades (S series)
with guard grille for short nozzle

Connection diagram

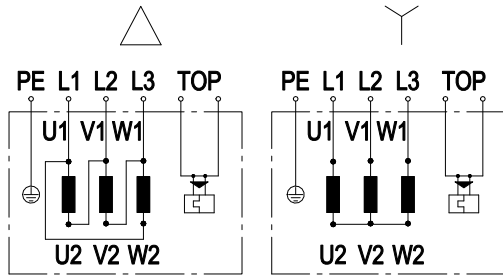

Note: Change of rotation direction by reversing two phases

Δ	Delta connection	Y	Star connection	L1	black
L2	blue	L3	brown	U1	black
V1	blue	W1	brown	U2	green
V2	white	W2	yellow	TOP	2x gray
PE	green/yellow				



AC axial fan

sickle-shaped blades (S series)
with guard grille for short nozzle

Curves: Air performance 50 Hz

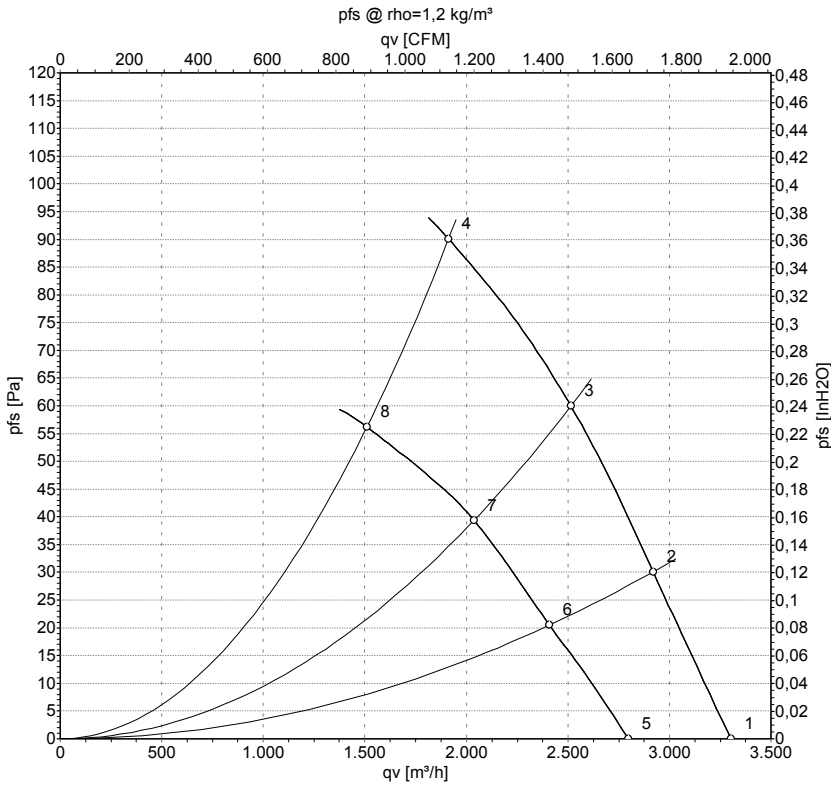

Measurement: LU-140791-1
Measurement: LU-140796-1

Air performance measured according to ISO 5801 installation category A. For detailed information on the measurement setup, contact ebm-papst. Intake sound level: Sound power level according to ISO 13347 / sound pressure level measured at 1 m distance from fan axis. The values given are valid under the specified measuring conditions and may vary due to conditions of installation. For deviations from the standard configuration, the parameters have to be checked on the installed unit.

Measured values

	Wired	U	f	n	P _e	I	qv	p _{fs}	qv	p _{fs}
		V	Hz	min ⁻¹	W	A	m ³ /h	Pa	CFM	inH2O
1	Δ	400	50	1405	135	0.36	3305	0	1945	0.00
2	Δ	400	50	1395	145	0.37	2920	30	1720	0.12
3	Δ	400	50	1385	156	0.37	2515	60	1480	0.24
4	Δ	400	50	1370	170	0.40	1910	90	1125	0.36
5	Y	400	50	1195	92	0.16	2800	0	1645	0.00
6	Y	400	50	1160	99	0.17	2410	20	1420	0.08
7	Y	400	50	1120	107	0.18	2040	40	1200	0.16
8	Y	400	50	1080	115	0.20	1510	56	890	0.22

Wired = Wiring · U = Power supply · f = Frequency · n = Speed (rpm) · P_e = Power consumption · I = Current draw · qv = Air flow · p_{fs} = Pressure increase



AC axial fan

sickle-shaped blades (S series)
with guard grille for short nozzle

Curves: Air performance 60 Hz

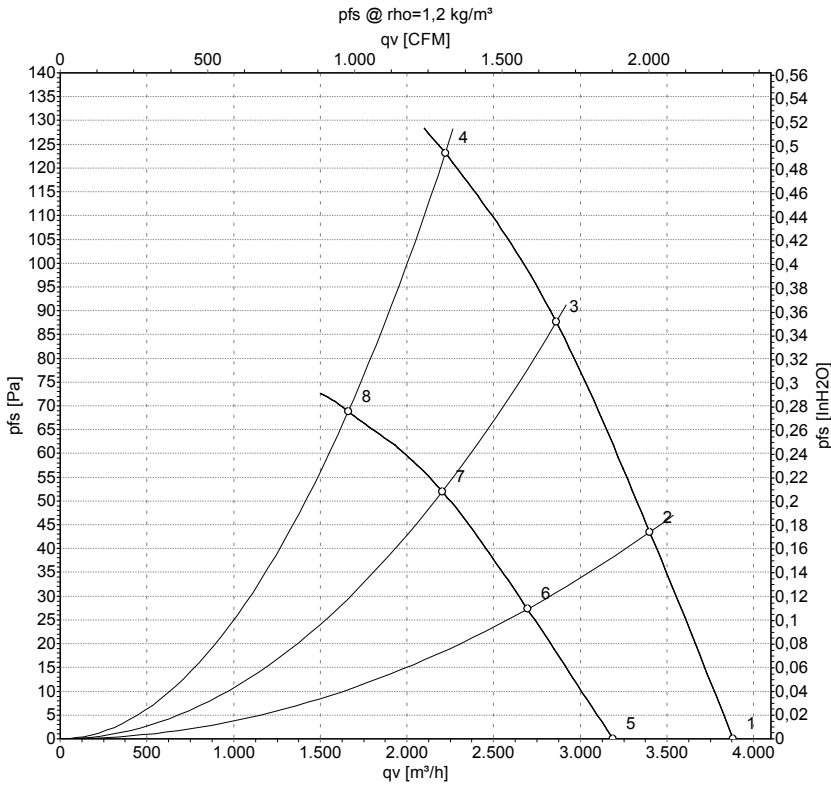

Measurement: LU-140793-1
Measurement: LU-140795-1

Air performance measured according to ISO 5801 installation category A. For detailed information on the measurement setup, contact ebm-papst. Intake sound level: Sound power level according to ISO 13347 / sound pressure level measured at 1 m distance from fan axis. The values given are valid under the specified measuring conditions and may vary due to conditions of installation. For deviations from the standard configuration, the parameters have to be checked on the installed unit.

Measured values

	Wired	U	f	n	P _e	I	qv	p _{fs}	qv	p _{fs}
		V	Hz	min ⁻¹	W	A	m ³ /h	Pa	CFM	inH2O
1	Δ	480	60	1660	202	0.39	3880	0	2285	0.00
2	Δ	480	60	1635	226	0.40	3400	44	2000	0.18
3	Δ	480	60	1615	245	0.42	2860	88	1685	0.35
4	Δ	480	60	1590	260	0.44	2230	125	1315	0.50
5	Y	480	60	1360	146	0.20	3190	0	1880	0.00
6	Y	480	60	1300	158	0.22	2695	27	1585	0.11
7	Y	480	60	1245	168	0.23	2205	52	1300	0.21
8	Y	480	60	1190	175	0.25	1670	69	985	0.28

Wired = Wiring · U = Power supply · f = Frequency · n = Speed (rpm) · P_e = Power consumption · I = Current draw · qv = Air flow · p_{fs} = Pressure increase

