

AC axial fan

sickle-shaped blades (S series)
with guard grille for short nozzle

S4D350-AN22-77 ebmpapst Datasheet
sales@fansco.com
www.fansco.com

Limited partnership · Headquarters Mulfingen
Amtsgericht (court of registration) Stuttgart · HRA 590344
General partner Elektrobau Mulfingen GmbH · Headquarters Mulfingen
Amtsgericht (court of registration) Stuttgart · HRB 590142

Nominal data

Type	S4D350-AN22-77			
Motor	M4D074-DF			
Phase		3~	3~	3~
Nominal voltage	VAC	400	400	480
Wiring		Y	Y	Y
Frequency	Hz	50	60	60
Method of obtaining data		ml	ml	ml
Valid for approval/standard		CE	CE	CE
Speed (rpm)	min ⁻¹	930	830	990
Power consumption	W	95	100	135
Current draw	A	0.16	0.17	0.18
Max. back pressure	Pa	40	30	42
Max. back pressure	inH ₂ O	0.16	0.12	0.17
Min. ambient temperature	°C	-40	-40	-40
Max. ambient temperature	°C	80	65	55

ml = Max. load · me = Max. efficiency · fa = Free air · cs = Customer specification · ce = Customer equipment
Subject to change



AC axial fan

sickle-shaped blades (S series)
with guard grille for short nozzle

Technical description

Weight	4.7 kg
Fan size	350 mm
Rotor surface	Painted black
Blade material	Press-fitted sheet steel blank, sprayed with PP plastic
Guard grille material	Steel, phosphated and coated with black plastic
Number of blades	5
Airflow direction	"V"
Direction of rotation	Counterclockwise, viewed toward rotor
Degree of protection	IP44; installation- and position-dependent as per EN 60034-5
Insulation class	"F"
Moisture (F) / Environmental (H) protection class	F2-2
Max. permitted ambient temp. for motor (transport/storage)	+ 80 °C
Min. permitted ambient temp. for motor (transport/storage)	- 40 °C
Installation position	Shaft horizontal or rotor on bottom; rotor on top on request
Condensation drainage holes	On rotor side
Mode	S1
Motor bearing	Ball bearing with low-temperature lubricant
Touch current according to IEC 60990 (measuring circuit Fig. 4, TN system)	< 0.75 mA
Motor protection	Thermal overload protector (TOP) with basic insulation
With cable	Variable
Protection class	I (with customer connection of protective earth)
Conformity with standards	EN 60335-1; CE
Approval	UL 1004-1; CSA C22.2 No. 100



AC axial fan

sickle-shaped blades (S series)
with guard grille for short nozzle

Product drawing

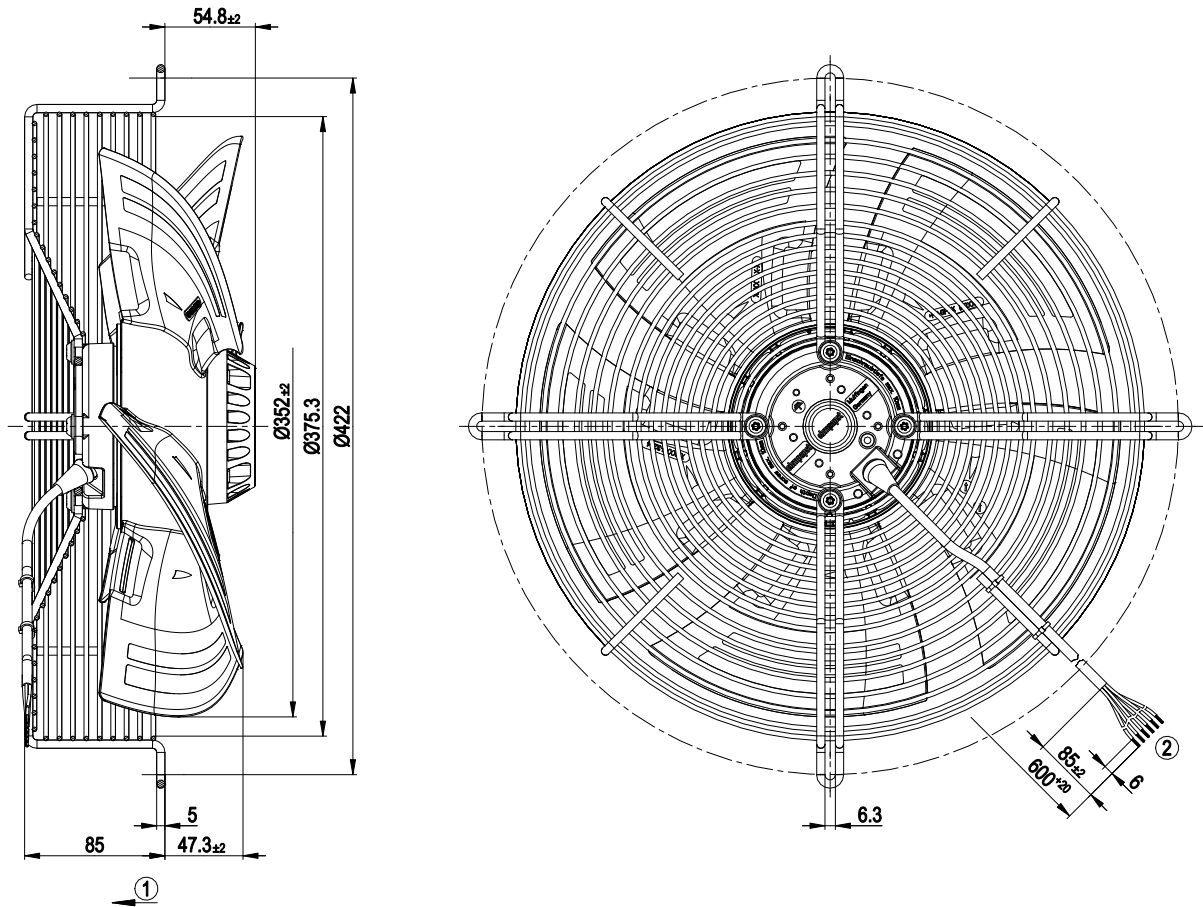

1	Direction of air flow "V"
2	Cable PFA AWG 20 (green/yellow AWG 18), 6x crimped splices
3	Terminal box included separately



AC axial fan

sickle-shaped blades (S series)
with guard grille for short nozzle

Connection diagram

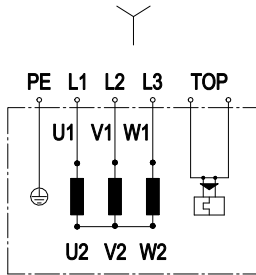

Note: Change of rotation direction by reversing two phases

Y	Star connection	L1	= U1 = black	L2	= V1 = blue
L3	= W1 = brown	PE	green/yellow	TOP	2x gray



AC axial fan

sickle-shaped blades (S series)
with guard grille for short nozzle

Curves: Air performance 50 Hz

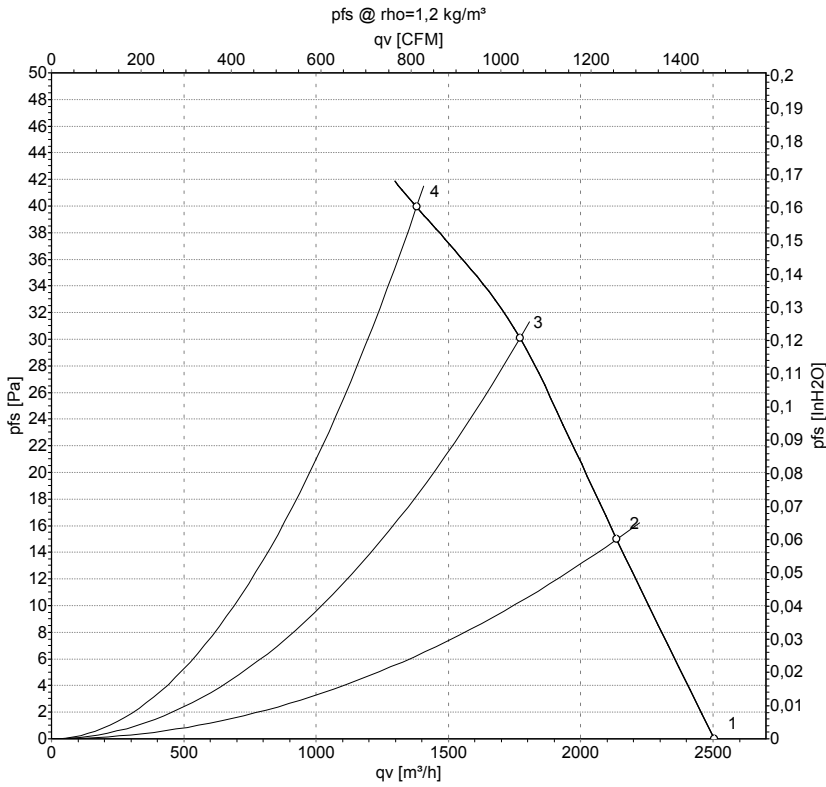

Measurement: LU-140571-1

Air performance measured according to ISO 5801 installation category A. For detailed information on the measurement setup, contact ebm-papst. Intake sound level: Sound power level according to ISO 13347 / sound pressure level measured at 1 m distance from fan axis. The values given are valid under the specified measuring conditions and may vary due to conditions of installation. For deviations from the standard configuration, the parameters have to be checked on the installed unit.

Measured values

	Wired	U	f	n	P _e	I	qv	p _{fs}	qv	p _{fs}
		V	Hz	min ⁻¹	W	A	m ³ /h	Pa	CFM	inH2O
1	Y	400	50	1080	80	0.13	2505	0	1475	0.00
2	Y	400	50	1025	85	0.14	2135	15	1260	0.06
3	Y	400	50	980	89	0.15	1770	30	1040	0.12
4	Y	400	50	930	95	0.16	1380	40	810	0.16

Wired = Wiring · U = Power supply · f = Frequency · n = Speed (rpm) · P_e = Power consumption · I = Current draw · qv = Air flow · p_{fs} = Pressure increase



AC axial fan

sickle-shaped blades (S series)
with guard grille for short nozzle

Curves: Air performance 60 Hz

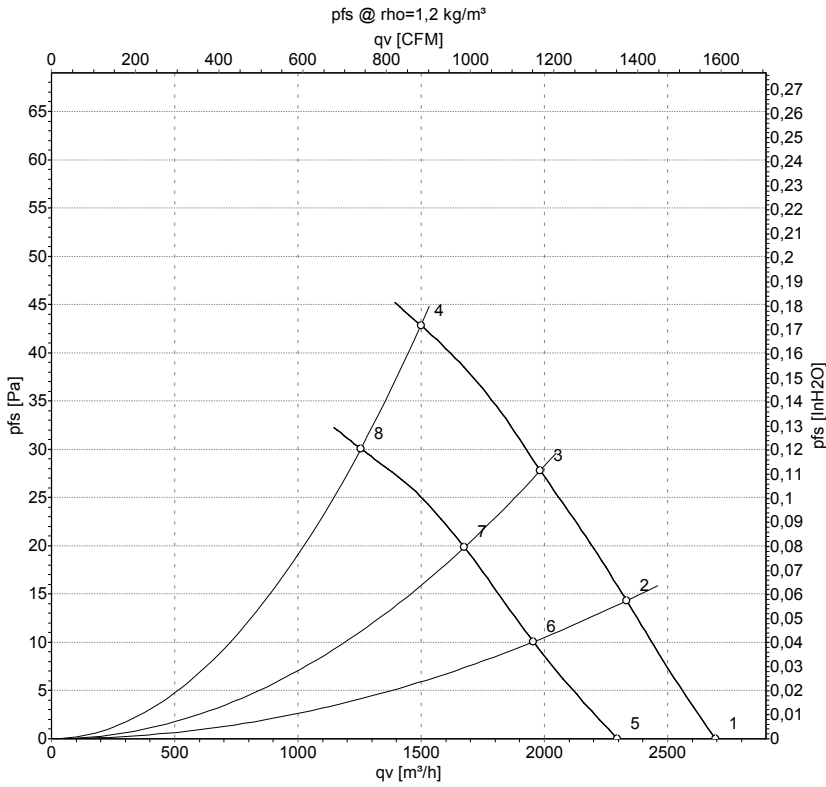

Measurement: LU-140577-1
Measurement: LU-140575-1

Air performance measured according to ISO 5801 installation category A. For detailed information on the measurement setup, contact ebm-papst. Intake sound level: Sound power level according to ISO 13347 / sound pressure level measured at 1 m distance from fan axis. The values given are valid under the specified measuring conditions and may vary due to conditions of installation. For deviations from the standard configuration, the parameters have to be checked on the installed unit.

Measured values

	Wired	U	f	n	P _e	I	qv	p _{fs}	qv	p _{fs}
		V	Hz	min ⁻¹	W	A	m ³ /h	Pa	CFM	inH2O
1	Y	480	60	1160	119	0.16	2695	0	1585	0.00
2	Y	480	60	1100	124	0.17	2335	14	1375	0.06
3	Y	480	60	1045	128	0.17	1985	28	1170	0.11
4	Y	480	60	990	135	0.18	1500	42	880	0.17
5	Y	400	60	985	94	0.16	2295	0	1350	0.00
6	Y	400	60	925	96	0.16	1955	10	1150	0.04
7	Y	400	60	880	98	0.16	1675	20	985	0.08
8	Y	400	60	830	100	0.17	1255	30	740	0.12

Wired = Wiring · U = Power supply · f = Frequency · n = Speed (rpm) · P_e = Power consumption · I = Current draw · qv = Air flow · p_{fs} = Pressure increase

