

AC axial fan

straight blades (A series)

with guard grille for short nozzle

S4D350-AA28-83 ebmpapst Datasheet

sales@fansco.com

www.fansco.com

Limited partnership · Headquarters Mulfingen

Amtsgericht (court of registration) Stuttgart · HRA 590344

General partner Elektrobau Mulfingen GmbH · Headquarters Mulfingen

Amtsgericht (court of registration) Stuttgart · HRB 590142

Nominal data

Type	S4D350-AA28-83		
Motor	M4D068-EC		
Phase		3~	3~
Nominal voltage	VAC	400	460
Wiring		Y	Y
Frequency	Hz	50	60
Method of obtaining data		fa	fa
Valid for approval/standard		-	-
Speed	min ⁻¹	1380	1600
Power consumption	W	125	195
Current draw	A	0.28	0.32
Max. back pressure	Pa	150	140
Max. ambient temperature	°C	80	50
Starting current	A	1.1	

ml = Max. load · me = Max. efficiency · fa = Free air · cs = Customer specification · ce = Customer equipment
Subject to change



AC axial fan

straight blades (A series)
with guard grille for short nozzle

Technical description

Weight	3.9 kg
Fan size	350 mm
Rotor surface	Painted black
Blade material	Sheet steel, painted black
Guard grille material	Steel, phosphated and coated with black plastic
Number of blades	5
Airflow direction	"V"
Direction of rotation	Counterclockwise, viewed toward rotor
Degree of protection	IP44; installation- and position-dependent as per EN 60034-5
Insulation class	"F"
Moisture (F) / Environmental (H) protection class	F2-2
Max. permitted ambient temp. for motor (transport/storage)	+ 80 °C
Min. permitted ambient temp. for motor (transport/storage)	- 40 °C
Installation position	Shaft horizontal or rotor on bottom; rotor on top on request
Condensation drainage holes	On rotor side
Mode	S1
Motor storage	Ball bearing
Touch current according to IEC 60990 (measuring circuit Fig. 4, TN system)	< 0.75 mA
Motor protection	Thermal overload protector (TOP) externally wired
With cable	Lateral
Protection class	I (with customer connection of protective earth)
Conformity with standards	EN 60335-1



AC axial fan

straight blades (A series)
with guard grille for short nozzle

Product drawing

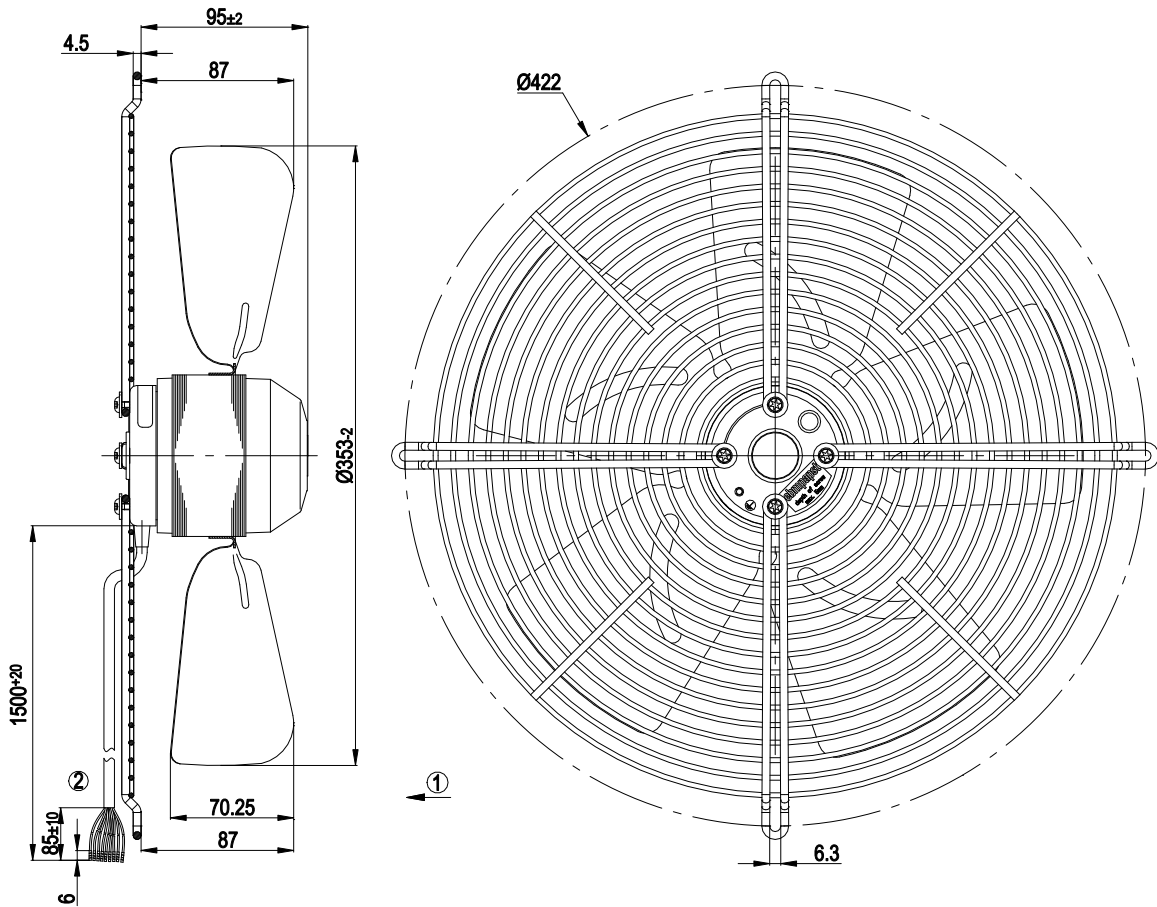

- | | |
|---|---|
| 1 | Direction of air flow "V" |
| 2 | Cable halogen-silicone-free 6G 0.5 mm ² , 6x crimped splices |



AC axial fan

straight blades (A series)
with guard grille for short nozzle

Connection diagram

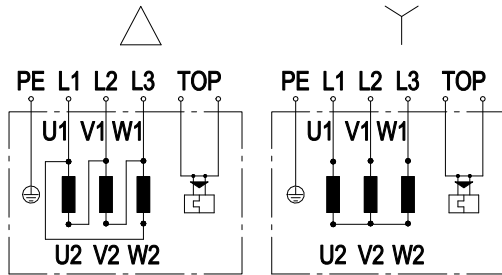

Δ	Delta connection	Y	Star connection	L1	black
L2	blue	L3	brown	U1	black
V1	blue	W1	brown	U2	green
V2	white	W2	yellow	TOP	2x gray
PE	green/yellow				



AC axial fan

straight blades (A series)
with guard grille for short nozzle

Curves: Air performance 50 Hz

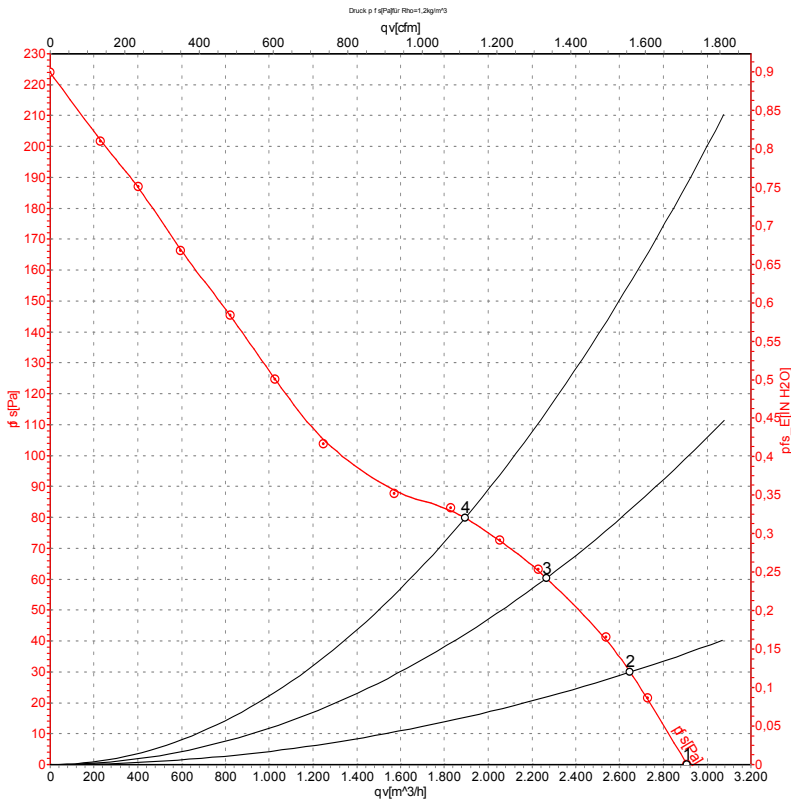

Measurement: LU-41972

Air performance measured according to ISO 5801 installation category A. For detailed information on the measurement setup, contact ebm-papst. Intake sound level: Sound power level according to ISO 13347 / sound pressure level measured at 1 m distance from fan axis. The values given are valid under the specified measuring conditions and may vary due to conditions of installation. For deviations from the standard configuration, the parameters have to be checked on the installed unit.

Measured values

	U	f	n	P _e	I	qv	p _{fs}
	V	Hz	min ⁻¹	W	A	m ³ /h	Pa
1	400	50	1380	125	0.28	2910	0
2	400	50	1375	136	0.28	2650	30
3	400	50	1360	147	0.29	2265	60
4	400	50	1345	155	0.30	1895	80

U = Power supply · f = Frequency · n = Speed · P_e = Power consumption · I = Current draw · qv = Air flow · p_{fs} = Pressure increase



AC axial fan

straight blades (A series)
with guard grille for short nozzle

Curves: Air performance 60 Hz

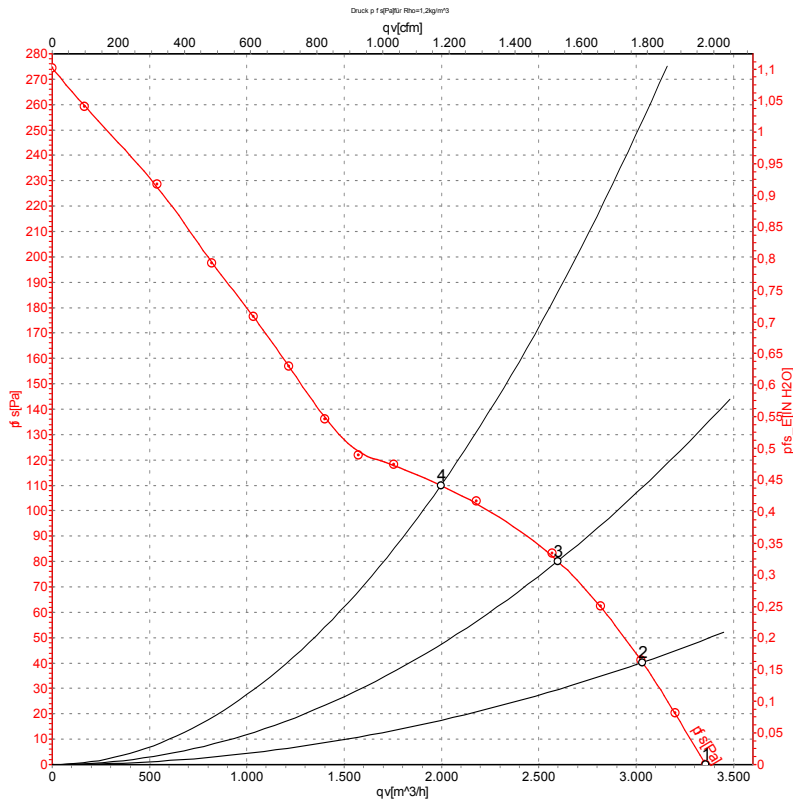

Measurement: LU-41974

Air performance measured according to ISO 5801 installation category A. For detailed information on the measurement setup, contact ebm-papst. Intake sound level: Sound power level according to ISO 13347 / sound pressure level measured at 1 m distance from fan axis. The values given are valid under the specified measuring conditions and may vary due to conditions of installation. For deviations from the standard configuration, the parameters have to be checked on the installed unit.

Measured values

	U	f	n	P _e	I	qv	p _{fs}
	V	Hz	min ⁻¹	W	A	m ³ /h	Pa
1	460	60	1600	195	0.32	3355	0
2	460	60	1585	212	0.32	3030	40
3	460	60	1560	230	0.34	2595	80
4	460	60	1540	244	0.35	1995	110

U = Power supply · f = Frequency · n = Speed · P_e = Power consumption · I = Current draw · qv = Air flow · p_{fs} = Pressure increase

