

AC axial fan

sickle-shaped blades (S series)

with guard grille for full nozzle

S4D330-BP10-31 ebmpapst Datasheet

sales@fansco.com

www.fansco.com

Limited partnership · Headquarters Mulfingen

Amtsgericht (court of registration) Stuttgart · HRA 590344

General partner Elektrobau Mulfingen GmbH · Headquarters Mulfingen

Amtsgericht (court of registration) Stuttgart · HRB 590142

Nominal data

Type	S4D330-BP10-31				
Motor	M4D068-DF				
Phase		3~	3~	3~	3~
Nominal voltage	VAC	230	230	400	400
Wiring		Δ	Δ	Y	Y
Frequency	Hz	50	60	50	60
Method of obtaining data		fa	fa	fa	fa
Valid for approval/standard		CE	CE	CE	CE
Speed (rpm)	min ⁻¹	1390	1570	1390	1570
Power consumption	W	100	130	100	130
Current draw	A	0.45	0.43	0.26	0.25
Max. back pressure	Pa	120	120	120	120
Max. back pressure	inH ₂ O	0.48	0.48	0.48	0.48
Min. ambient temperature	°C	-25	-25	-25	-25
Max. ambient temperature	°C	55	45	55	45
Starting current	A	1.3	1.3	0.75	0.75

ml = Max. load · me = Max. efficiency · fa = Free air · cs = Customer specification · ce = Customer equipment
Subject to change



AC axial fan

sickle-shaped blades (S series)
with guard grille for full nozzle

Technical description

Weight	3.7 kg
Fan size	330 mm
Rotor surface	Painted black
Blade material	Sheet steel, painted black
Guard grille material	Steel, phosphated and coated with black plastic
Number of blades	5
Airflow direction	"A"
Direction of rotation	Clockwise, viewed toward rotor
Degree of protection	IP44; installation- and position-dependent as per EN 60034-5
Insulation class	"B"
Moisture (F) / Environmental (H) protection class	H0+
Max. permitted ambient temp. for motor (transport/storage)	+ 80 °C
Min. permitted ambient temp. for motor (transport/storage)	- 40 °C
Installation position	Any
Condensation drainage holes	On rotor side
Mode	S1
Motor bearing	Ball bearing
Touch current according to IEC 60990 (measuring circuit Fig. 4, TN system)	< 0.75 mA
With cable	Axial
Protection class	I (with customer connection of protective earth)
Conformity with standards	CE
Approval	CCC; EAC



AC axial fan

sickle-shaped blades (S series)
with guard grille for full nozzle

Product drawing

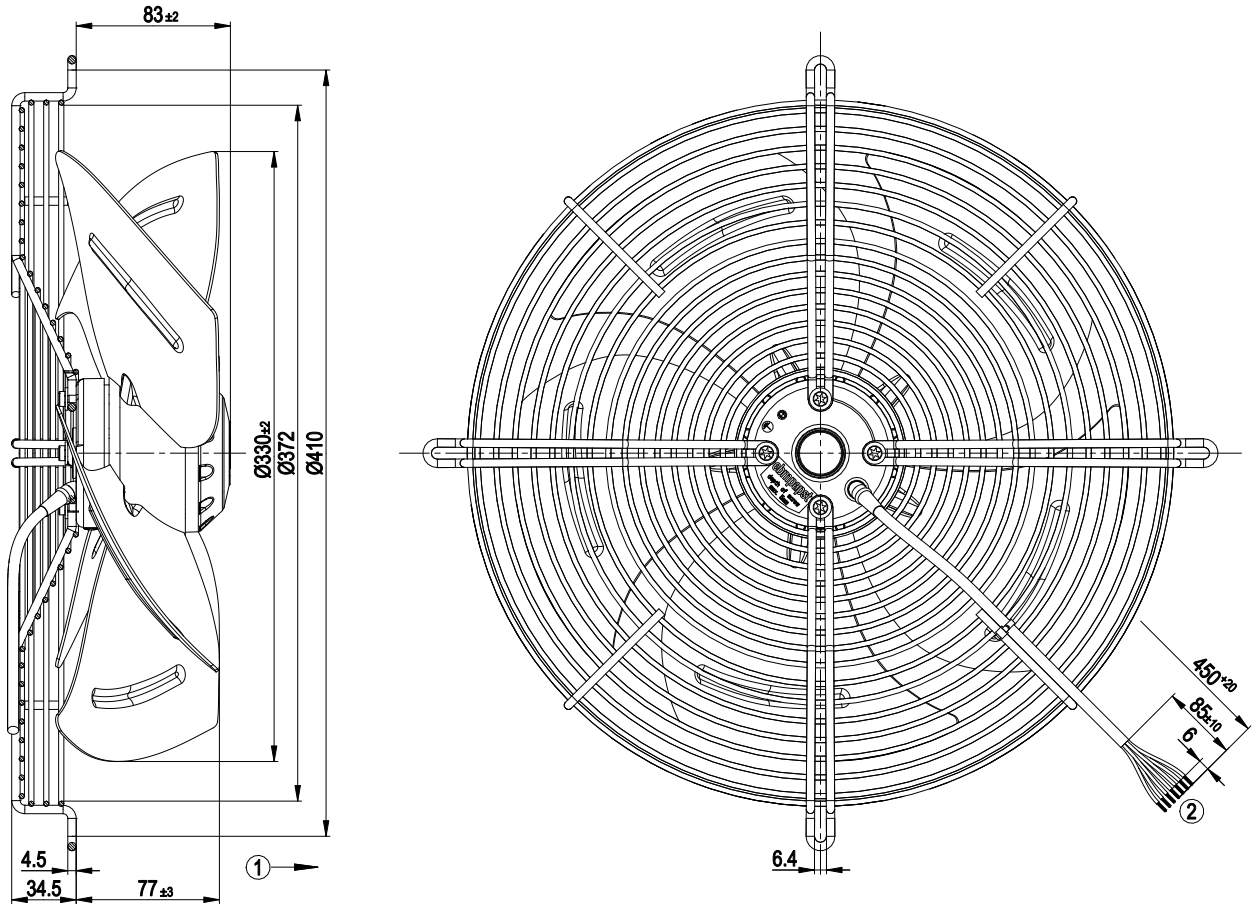

- | | |
|---|---|
| 1 | Direction of air flow "A" |
| 2 | Cable PVC 7G 0.5 mm ² , 7x crimped splices |



AC axial fan

sickle-shaped blades (S series)
with guard grille for full nozzle

Connection diagram

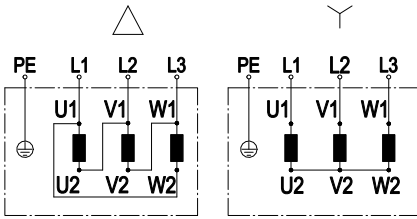

Change of rotation direction by reversing two phases

	Three-phase motor	Δ	Delta connection	Y	Star connection
L1	= U1 = black	L2	= V1 = blue	L3	= W1 = brown
U2	green	V2	white	W2	yellow
PE	green/yellow				



AC axial fan

sickle-shaped blades (S series)
with guard grille for full nozzle

Curves: Air performance 50 Hz

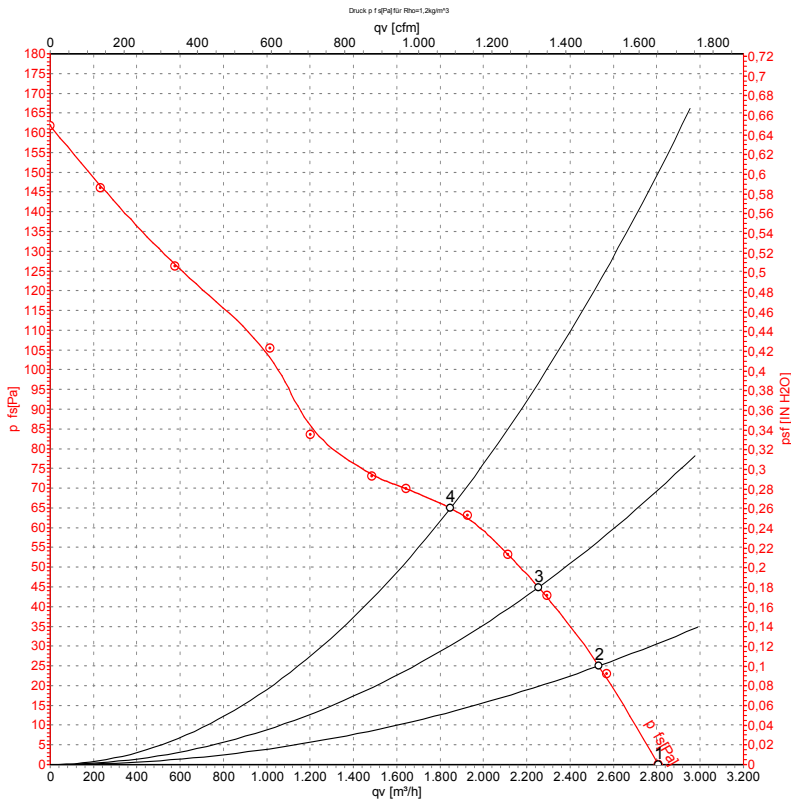

Measurement: LU-33322-1

Air performance measured according to ISO 5801 installation category A. For detailed information on the measurement setup, contact ebm-papst. Intake sound level: Sound power level according to ISO 13347 / sound pressure level measured at 1 m distance from fan axis. The values given are valid under the specified measuring conditions and may vary due to conditions of installation. For deviations from the standard configuration, the parameters have to be checked on the installed unit.

Measured values

	U	f	n	P _e	I	q _v	p _{fs}	q _v	p _{fs}
	V	Hz	min ⁻¹	W	A	m ³ /h	Pa	cfm	inH ₂ O
1	400	50	1390	100	0.26	2805	0	1650	0.00
2	400	50	1375	102	0.26	2530	25	1490	0.10
3	400	50	1360	110	0.26	2255	45	1325	0.18
4	400	50	1335	120	0.26	1845	65	1085	0.26

U = Power supply · f = Frequency · n = Speed (rpm) · P_e = Power consumption · I = Current draw · q_v = Air flow · p_{fs} = Pressure increase



AC axial fan

sickle-shaped blades (S series)
with guard grille for full nozzle

Curves: Air performance 60 Hz

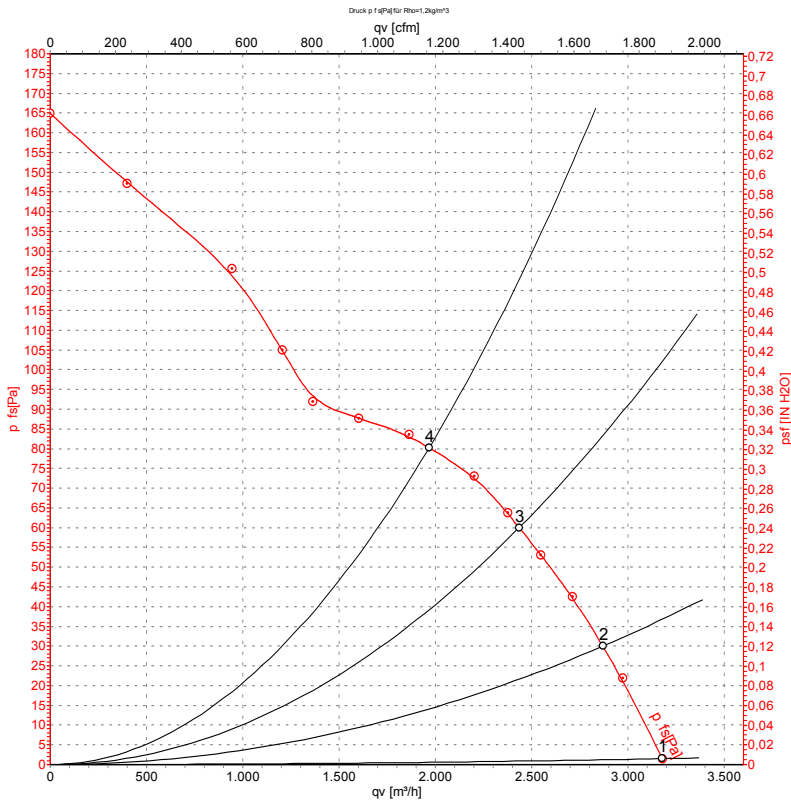

Measurement: LU-33323-1

Air performance measured according to ISO 5801 installation category A. For detailed information on the measurement setup, contact ebm-papst. Intake sound level: Sound power level according to ISO 13347 / sound pressure level measured at 1 m distance from fan axis. The values given are valid under the specified measuring conditions and may vary due to conditions of installation. For deviations from the standard configuration, the parameters have to be checked on the installed unit.

Measured values

	U	f	n	P _e	I	q _v	p _{fs}	q _v	p _{fs}
	V	Hz	min ⁻¹	W	A	m ³ /h	Pa	cfm	inH ₂ O
1	400	60	1570	130	0.25	3180	0	1870	0.00
2	400	60	1555	139	0.25	2870	30	1690	0.12
3	400	60	1510	155	0.25	2435	60	1435	0.24
4	400	60	1470	171	0.27	1970	80	1160	0.32

U = Power supply · f = Frequency · n = Speed (rpm) · P_e = Power consumption · I = Current draw · q_v = Air flow · p_{fs} = Pressure increase

