

AC axial fan

sickle-shaped blades (S series), single-intake
with guard grille for short nozzle

S4D330-AP30-34 ebmpapst Datasheet

sales@fansco.com

www.fansco.com

Limited partnership · Headquarters Mulfingen

Amtsgericht (court of registration) Stuttgart · HRA 590344

General partner Elektrobau Mulfingen GmbH · Headquarters Mulfingen

Amtsgericht (court of registration) Stuttgart · HRB 590142

Nominal data

Type	S4D330-AP30-34		
Motor	M4D068-DF		
Phase		3~	3~
Nominal voltage	VAC	400	460
Wiring		Y	Y
Frequency	Hz	50	60
Method of obtaining data		fa	fa
Valid for approval/standard		CE	CE
Speed (rpm)	min ⁻¹	1400	1640
Power consumption	W	95	135
Current draw	A	0.26	0.27
Max. back pressure	Pa	120	120
Max. back pressure	inH ₂ O	0.48	0.48
Min. ambient temperature	°C	-25	-25
Max. ambient temperature	°C	55	40
Starting current	A	0.79	0.8

ml = Max. load · me = Max. efficiency · fa = Free air · cs = Customer specification · ce = Customer equipment
Subject to change



AC axial fan

sickle-shaped blades (S series), single-intake
with guard grille for short nozzle

Technical description

Weight	4 kg
Fan size	330 mm
Rotor surface	Painted black
Blade material	Sheet steel, painted black
Guard grille material	Steel, coated with black plastic (RAL 9005)
Number of blades	5
Airflow direction	"V"
Direction of rotation	Counterclockwise, viewed toward rotor
Degree of protection	IP44; installation- and position-dependent as per EN 60034-5
Insulation class	"B"
Moisture (F) / Environmental (H) protection class	F2-2
Max. permitted ambient temp. for motor (transport/storage)	+ 80 °C
Min. permitted ambient temp. for motor (transport/storage)	- 40 °C
Installation position	Shaft horizontal or rotor on bottom; rotor on top on request
Condensation drainage holes	On rotor side
Mode	S1
Motor bearing	Ball bearing
Touch current according to IEC 60990 (measuring circuit Fig. 4, TN system)	< 0.75 mA
With cable	Axial
Protection class	I (with customer connection of protective earth)
Conformity with standards	EN 60335-1, motor does not have factory-installed overheating protection



S4D330-AP30-34

AC axial fan

sickle-shaped blades (S series), single-intake
with guard grille for short nozzle

Product drawing

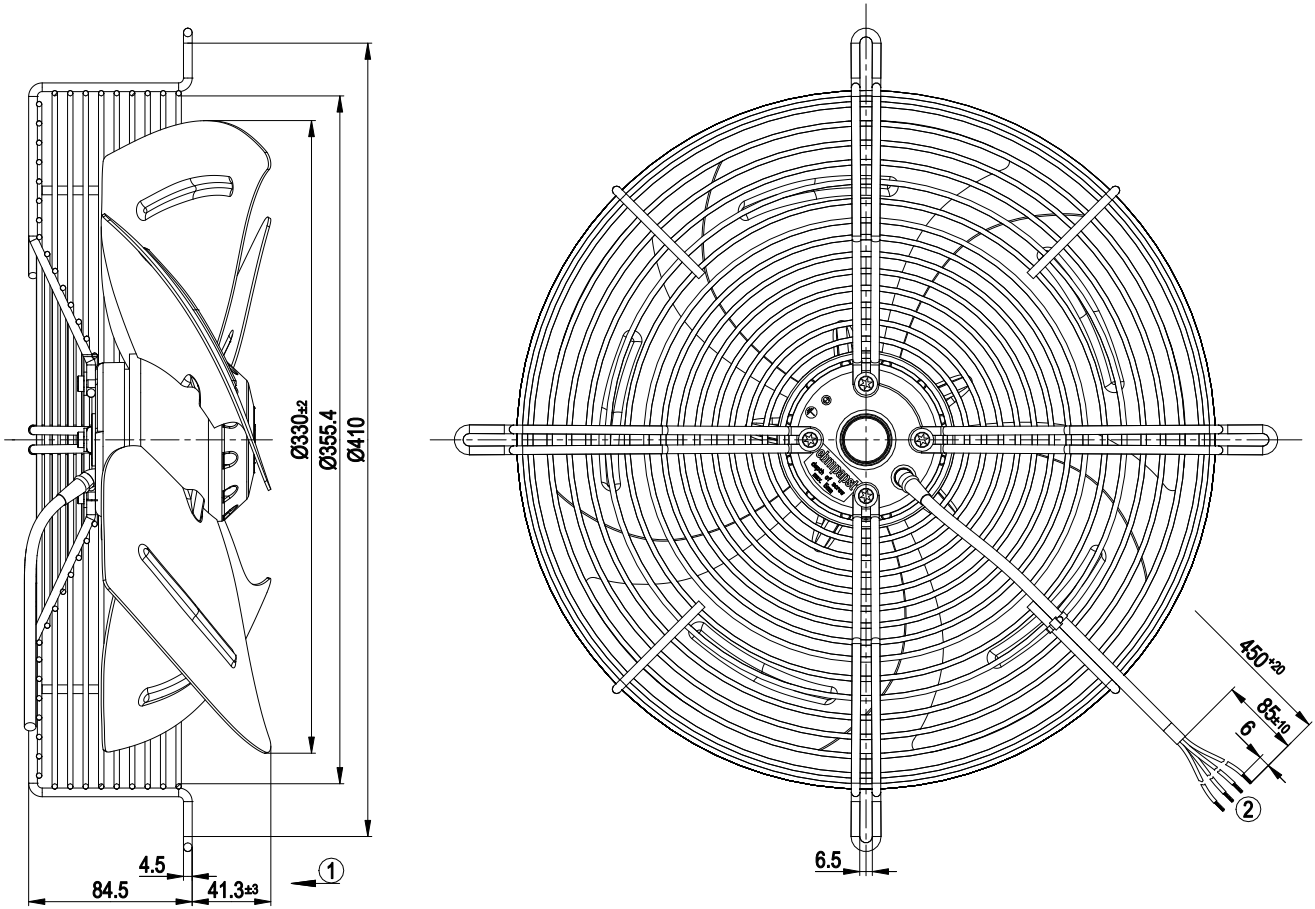

- | | |
|---|--|
| 1 | Direction of air flow "V" |
| 2 | Cable PFA AWG20 (green/yellow AWG18), 4x crimped splices |



AC axial fan

sickle-shaped blades (S series), single-intake
with guard grille for short nozzle

Connection diagram

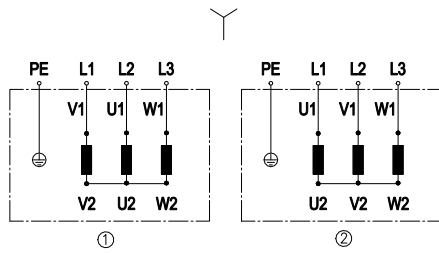

Change of rotation direction by reversing two phases

	Three-phase motor
Y	Star connection
1	Counterclockwise operation
L1	= V1 = blue
L2	= U1 = black
L3	= W1 = brown
2	Clockwise operation
L1	= U1 = black
L2	= V1 = blue
L3	= W1 = brown
PE	green/yellow



AC axial fan

sickle-shaped blades (S series), single-intake
with guard grille for short nozzle

Curves: Air performance 50 Hz

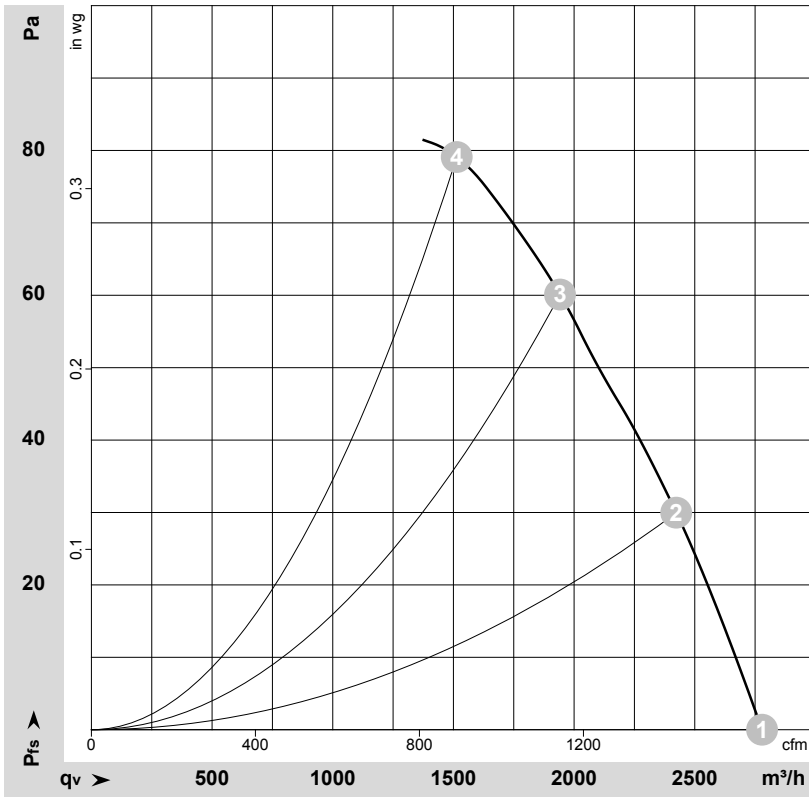

$\rho = 1.15 \text{ kg/m}^3 \pm 2 \%$

Measurement: LU-57378-1

Air performance measured according to ISO 5801 installation category A. For detailed information on the measurement setup, contact ebmpapst. Intake sound level: Sound power level according to ISO 13347 / sound pressure level measured at 1 m distance from fan axis. The values given are valid under the specified measuring conditions and may vary due to conditions of installation. For deviations from the standard configuration, the parameters have to be checked on the installed unit.

Measured values

	U	f	n	P _e	I	qv	p _{fs}	qv	p _{fs}
	V	Hz	min ⁻¹	W	A	m ³ /h	Pa	CFM	inH ₂ O
1	400	50	1400	95	0.26	2780	0	1635	0.00
2	400	50	1370	105	0.25	2425	30	1425	0.12
3	400	50	1345	118	0.25	1940	60	1145	0.24
4	400	50	1320	129	0.26	1515	80	890	0.32

U = Power supply · f = Frequency · n = Speed (rpm) · P_e = Power consumption · I = Current draw · qv = Air flow · p_{fs} = Pressure increase



AC axial fan

sickle-shaped blades (S series), single-intake
with guard grille for short nozzle

Curves: Air performance 60 Hz

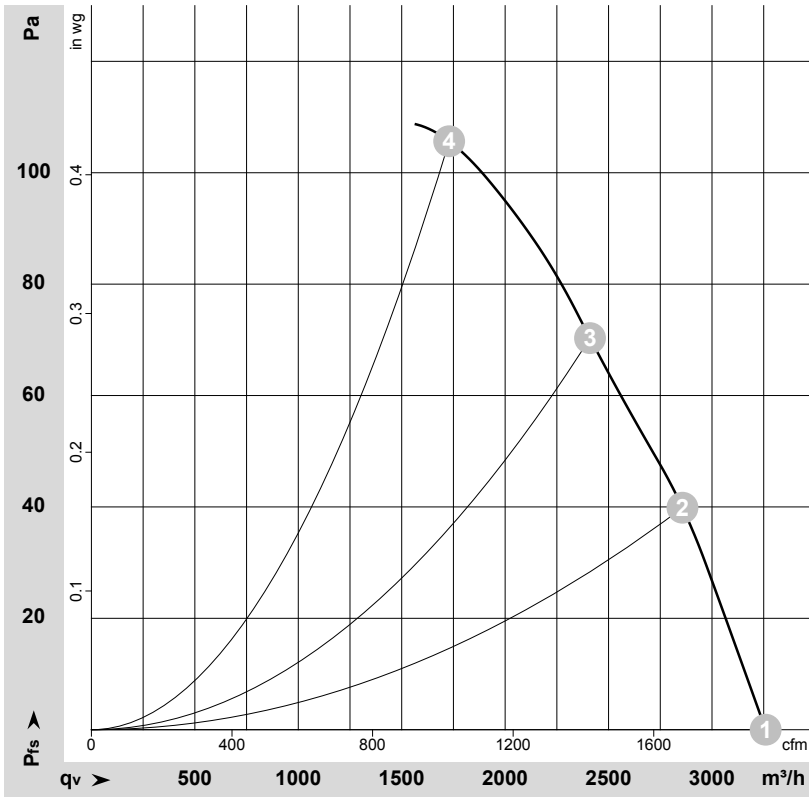

$\rho = 1.15 \text{ kg/m}^3 \pm 2 \%$

Measurement: LU-57431-1

Air performance measured according to ISO 5801 installation category A. For detailed information on the measurement setup, contact ebmpapst. Intake sound level: Sound power level according to ISO 13347 / sound pressure level measured at 1 m distance from fan axis. The values given are valid under the specified measuring conditions and may vary due to conditions of installation. For deviations from the standard configuration, the parameters have to be checked on the installed unit.

Measured values

	U	f	n	P _e	I	q _v	p _{fs}	q _v	p _{fs}
	V	Hz	min ⁻¹	W	A	m ³ /h	Pa	CFM	inH ₂ O
1	460	60	1640	135	0.27	3260	0	1920	0.00
2	460	60	1605	155	0.28	2855	40	1680	0.16
3	460	60	1575	170	0.29	2410	70	1420	0.28
4	460	60	1525	196	0.31	1730	105	1020	0.42

U = Power supply · f = Frequency · n = Speed (rpm) · P_e = Power consumption · I = Current draw · q_v = Air flow · p_{fs} = Pressure increase

