

AC axial fan

straight blades (A series), single-intake
with guard grille for full nozzle

S4D315-BC20-16 ebmpapst Datasheet
sales@fansco.com
www.fansco.com

Limited partnership · Headquarters Mulfingen
Amtsgericht (court of registration) Stuttgart · HRA 590344
General partner Elektrobau Mulfingen GmbH · Headquarters Mulfingen
Amtsgericht (court of registration) Stuttgart · HRB 590142

Nominal data

Type	S4D315-BC20-16				
Motor	M4D068-EC				
Phase		3~	3~	3~	3~
Nominal voltage	VAC	230	230	440	440
Wiring		Δ	Δ	Y	Y
Frequency	Hz	50	60	50	60
Method of obtaining data		fa	fa		
Valid for approval/standard		CE	CE	CE	CE
Speed (rpm)	min ⁻¹	1400	1590	1410	1610
Power consumption	W	78	115	82	118
Current draw	A	0.33	0.37	0.2	0.2
Max. back pressure	Pa	150	150		
Max. back pressure	inH ₂ O	0.6	0.6		
Min. ambient temperature	°C	-25	-25	-25	-25
Max. ambient temperature	°C	80	60	-	-
Starting current	A	1.04	0.97		

ml = Max. load · me = Max. efficiency · fa = Free air · cs = Customer specification · ce = Customer equipment
Subject to change



AC axial fan

straight blades (A series), single-intake
with guard grille for full nozzle

Technical description

Weight	3.8 kg
Fan size	315 mm
Rotor surface	Painted black
Terminal box material	ABS plastic
Blade material	Sheet steel, painted black
Guard grille material	Steel, coated with black plastic (RAL 9005)
Number of blades	5
Airflow direction	"A"
Direction of rotation	Clockwise, viewed toward rotor
Degree of protection	IP44; installation- and position-dependent as per EN 60034-5
Insulation class	"B"
Moisture (F) / Environmental (H) protection class	H0+
Max. permitted ambient temp. for motor (transport/storage)	+ 80 °C
Min. permitted ambient temp. for motor (transport/storage)	- 40 °C
Installation position	Shaft horizontal or rotor on bottom; rotor on top on request
Condensation drainage holes	On rotor side
Mode	S1
Motor bearing	Ball bearing
Touch current according to IEC 60990 (measuring circuit Fig. 4, TN system)	< 0.75 mA
Electrical hookup	Via terminal box
With cable	Axial
Protection class	I (with customer connection of protective earth)
Conformity with standards	EN 60335-1, motor does not have factory-installed overheating protection



AC axial fan

straight blades (A series), single-intake
with guard grille for full nozzle

Product drawing

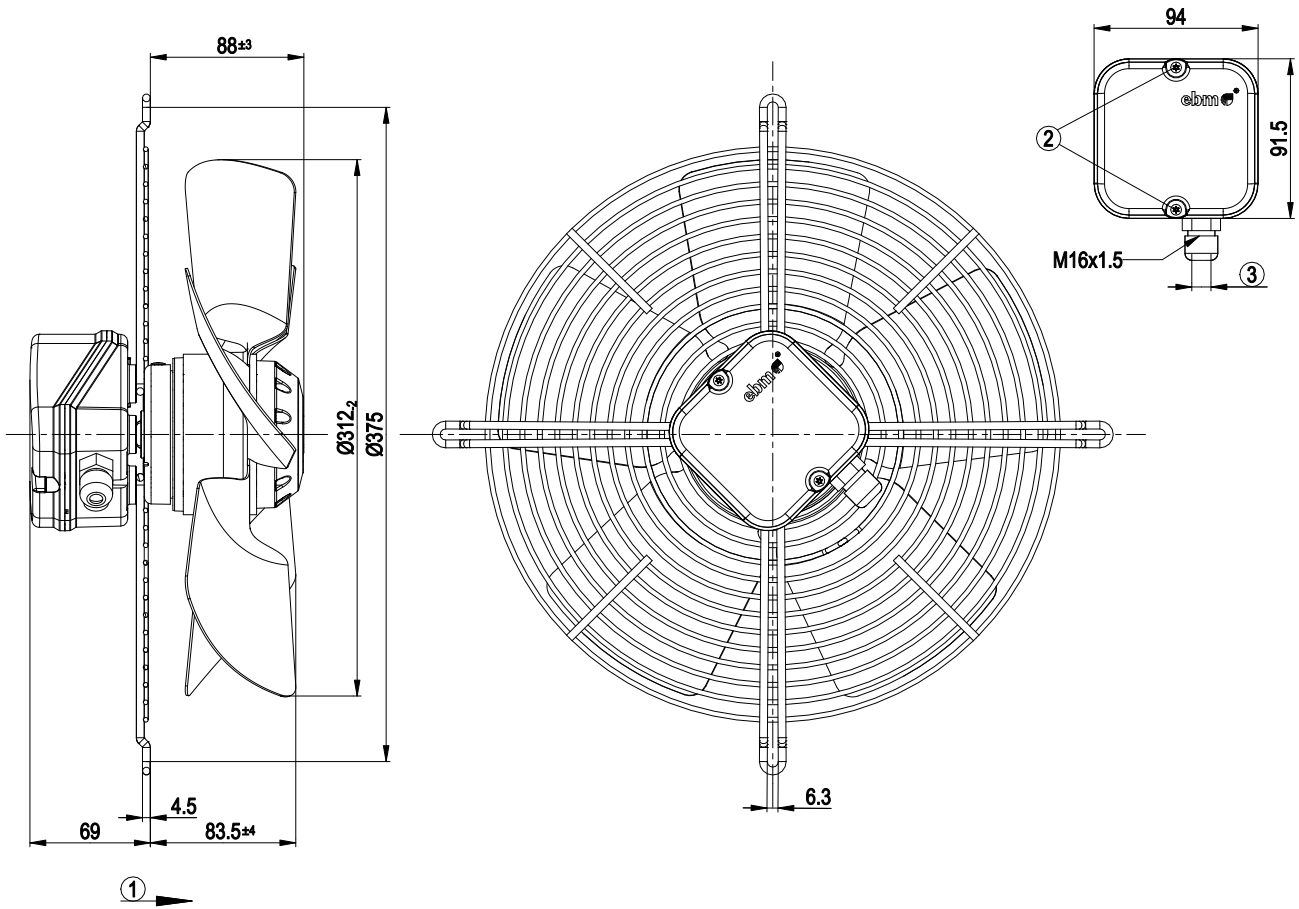

1	Direction of air flow "A"
2	Tightening torque 0.5 ± 0.1 Nm
3	Cable diameter max. 7.5 mm, tightening torque 1.3 ± 0.2 Nm



AC axial fan

straight blades (A series), single-intake
with guard grille for full nozzle

Connection diagram

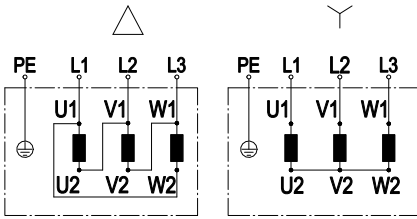

Change of rotation direction by reversing two phases

	Three-phase motor	Δ	Delta connection	Y	Star connection
L1	= U1 = black	L2	= V1 = blue	L3	= W1 = brown
U2	green	V2	white	W2	yellow
PE	green/yellow				



AC axial fan

straight blades (A series), single-intake
with guard grille for full nozzle

Curves: Air performance 50 Hz

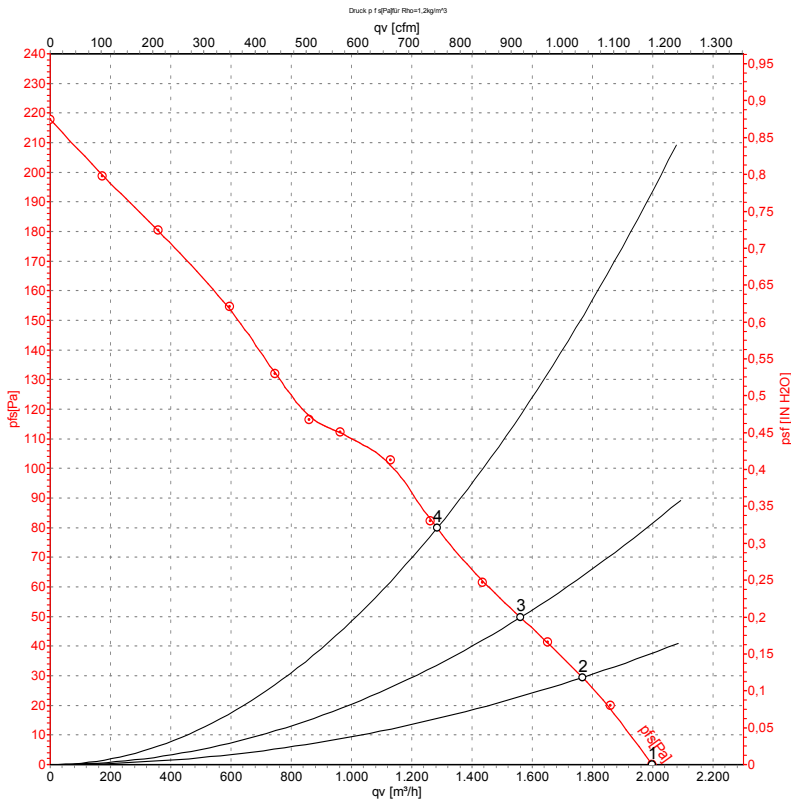

Measurement: LU-56877-1

Air performance measured according to ISO 5801 installation category A. For detailed information on the measurement setup, contact ebm-papst. Intake sound level: Sound power level according to ISO 13347 / sound pressure level measured at 1 m distance from fan axis. The values given are valid under the specified measuring conditions and may vary due to conditions of installation. For deviations from the standard configuration, the parameters have to be checked on the installed unit.

Measured values

	U	f	n	P _e	I	q _v	p _{fs}	q _v	p _{fs}
	V	Hz	min ⁻¹	W	A	m ³ /h	Pa	CFM	inH ₂ O
1	400	50	1400	78	0.19	1995	0	1175	0.00
2	400	50	1390	84	0.19	1765	29	1040	0.12
3	400	50	1385	87	0.20	1560	50	920	0.20
4	400	50	1375	94	0.20	1285	80	755	0.32

U = Power supply · f = Frequency · n = Speed (rpm) · P_e = Power consumption · I = Current draw · q_v = Air flow · p_{fs} = Pressure increase



AC axial fan

straight blades (A series), single-intake
with guard grille for full nozzle

Curves: Air performance 60 Hz

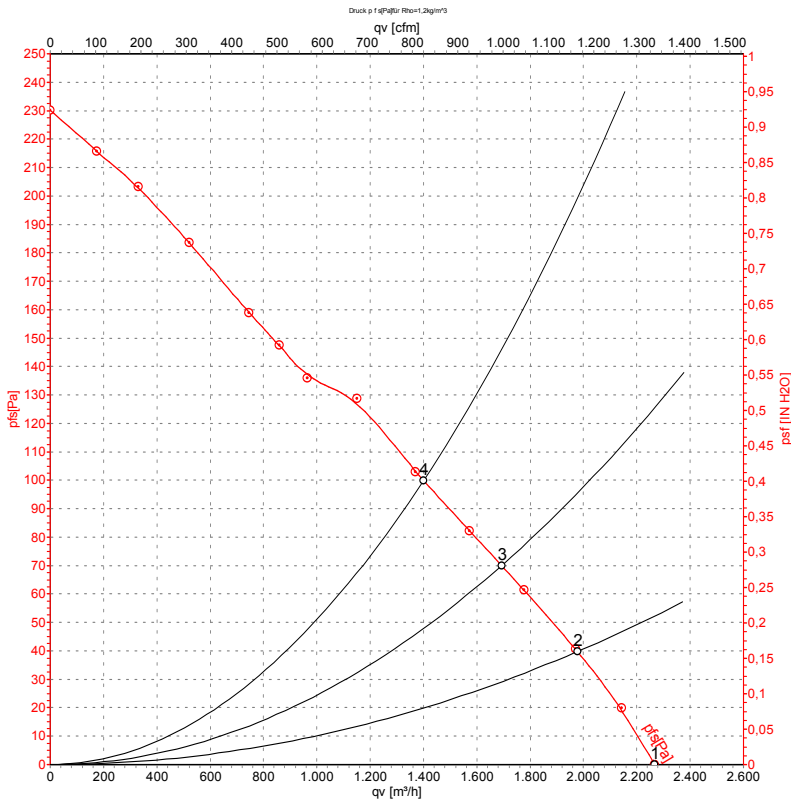

Measurement: LU-56878-1

Air performance measured according to ISO 5801 installation category A. For detailed information on the measurement setup, contact ebm-papst. Intake sound level: Sound power level according to ISO 13347 / sound pressure level measured at 1 m distance from fan axis. The values given are valid under the specified measuring conditions and may vary due to conditions of installation. For deviations from the standard configuration, the parameters have to be checked on the installed unit.

Measured values

	U	f	n	P _e	I	q _v	p _{fs}	q _v	p _{fs}
	V	Hz	min ⁻¹	W	A	m ³ /h	Pa	CFM	inH ₂ O
1	400	60	1590	115	0.21	2265	0	1335	0.00
2	400	60	1565	124	0.22	1975	40	1165	0.16
3	400	60	1555	129	0.22	1695	70	995	0.28
4	400	60	1530	138	0.24	1400	100	825	0.40

U = Power supply · f = Frequency · n = Speed (rpm) · P_e = Power consumption · I = Current draw · q_v = Air flow · p_{fs} = Pressure increase

