

S4D315-AP10-30

AC axial fan

sickle-shaped blades (S series)
with guard grille for short nozzle



S4D315-AP10-30 ebmpapst Datasheet
sales@fansco.com
www.fansco.com

Limited partnership · Headquarters Mulfingen
Amtsgericht (court of registration) Stuttgart · HRA 590344

General partner Elektrobau Mulfingen GmbH · Headquarters Mulfingen
Amtsgericht (court of registration) Stuttgart · HRB 590142

Nominal data

Type	S4D315-AP10-30				
Motor	M4D068-DF				
Phase		3~	3~	3~	3~
Nominal voltage	VAC	230	230	400	400
Wiring		Δ	Δ	Y	Y
Frequency	Hz	50	60	50	60
Method of obtaining data		fa	fa	fa	fa
Valid for approval/standard		CE	CE	CE	CE
Speed (rpm)	min ⁻¹	1400	1620	1400	1620
Power consumption	W	85	110	85	110
Current draw	A	0.45	0.42	0.26	0.24
Max. back pressure	Pa	120	120	120	120
Max. back pressure	in. wg	0.48	0.48	0.48	0.48
Min. ambient temperature	°C	-25	-25	-25	-25
Max. ambient temperature	°C	55	55	55	55
Starting current	A	1.3	1.3	0.75	0.75

ml = Max. load · me = Max. efficiency · fa = Free air · cs = Customer specification · ce = Customer equipment
Subject to change



AC axial fan

sickle-shaped blades (S series)
with guard grille for short nozzle

Technical description

Weight	3.66 kg
Size	315 mm
Motor size	68
Rotor surface	Painted black
Blade material	Sheet steel, painted black
Guard grille material	Steel, phosphated and coated with black plastic
Number of blades	5
Airflow direction	V
Direction of rotation	Counterclockwise, viewed toward rotor
Degree of protection	IP44
Insulation class	"B"
Moisture (F) / Environmental (H) protection class	H1
Max. permitted ambient temp. for motor (transport/storage)	+80 °C
Min. permitted ambient temp. for motor (transport/storage)	-40 °C
Installation position	Shaft horizontal or rotor on bottom; rotor on top on request
Condensation drainage holes	On rotor side
Mode	S1
Motor bearing	Ball bearing
Touch current according to IEC 60990 (measuring circuit Fig. 4, TN system)	< 0.75 mA
With cable	Axial
Protection class	I (with customer connection of protective earth)
Conformity with standards	EN 60335-1, motor does not have factory-installed overheating protection; CE
Approval	EAC; CCC



AC axial fan

sickle-shaped blades (S series)
with guard grille for short nozzle

Product drawing

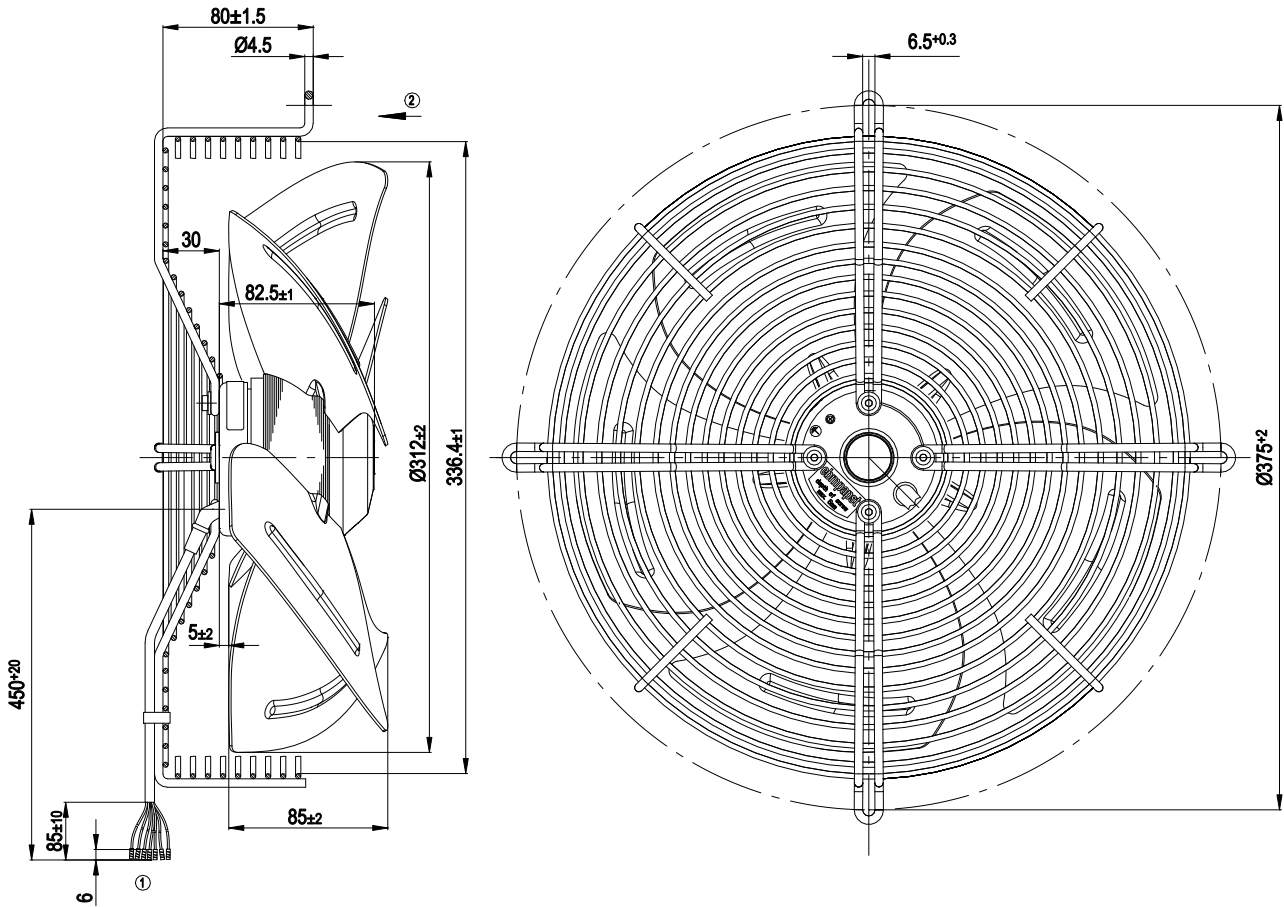

- 1 Cable PVC, 7x crimped splices
- 2 Direction of air flow "V"



AC axial fan

sickle-shaped blades (S series)
with guard grille for short nozzle

Connection diagram

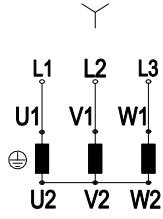

Note: Change of rotation direction by reversing two phases

Y	Star connection	L1	black	L2	blue
L3	brown	U1	black	V1	blue
W1	brown	U2	green	V2	white
W2	yellow				



AC axial fan

sickle-shaped blades (S series)
with guard grille for short nozzle

Curves: Air performance 50 Hz

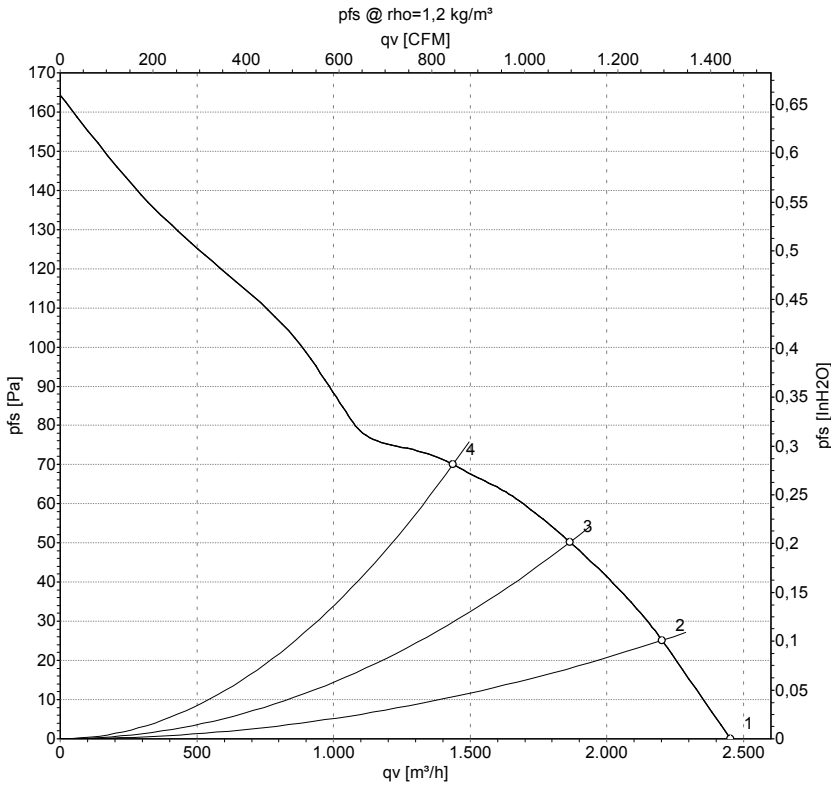

Measurement: LU-33324-1

Air performance measured according to ISO 5801 installation category A. For detailed information on the measurement setup, contact ebm-papst. Intake sound level: Sound power level according to ISO 13347 / sound pressure level measured at 1 m distance from fan axis. The values given are valid under the specified measuring conditions and may vary due to conditions of installation. For deviations from the standard configuration, the parameters have to be checked on the installed unit.

Measured values

	U	f	n	P _e	I	q _v	p _{fs}	q _v	p _{fs}
	V	Hz	min ⁻¹	W	A	m ³ /h	Pa	cfm	in. wg
1	400	50	1400	85	0.26	2450	0	1445	0.00
2	400	50	1395	89	0.26	2200	25	1295	0.10
3	400	50	1385	98	0.26	1865	50	1100	0.20
4	400	50	1360	108	0.27	1435	70	845	0.28

U = Voltage · f = Frequency · n = Speed (rpm) · P_e = Power consumption · I = Current draw · q_v = Air flow · p_{fs} = Pressure increase



AC axial fan

sickle-shaped blades (S series)
with guard grille for short nozzle

Curves: Air performance 60 Hz

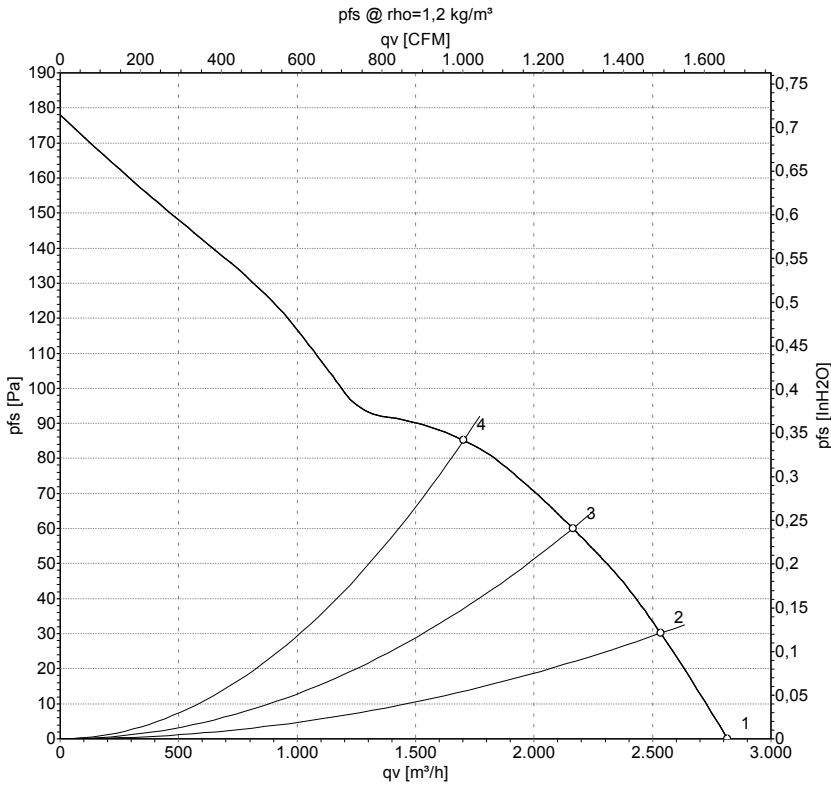

Measurement: LU-33325-1

Air performance measured according to ISO 5801 installation category A. For detailed information on the measurement setup, contact ebm-papst. Intake sound level: Sound power level according to ISO 13347 / sound pressure level measured at 1 m distance from fan axis. The values given are valid under the specified measuring conditions and may vary due to conditions of installation. For deviations from the standard configuration, the parameters have to be checked on the installed unit.

Measured values

	U	f	n	P _e	I	q _v	p _{fs}	q _v	p _{fs}
	V	Hz	min ⁻¹	W	A	m ³ /h	Pa	cfm	in. wg
1	400	60	1620	110	0.24	2815	0	1660	0.00
2	400	60	1600	119	0.24	2535	30	1490	0.12
3	400	60	1575	132	0.25	2165	60	1275	0.24
4	400	60	1535	147	0.26	1705	85	1000	0.34

U = Voltage · f = Frequency · n = Speed (rpm) · P_e = Power consumption · I = Current draw · q_v = Air flow · p_{fs} = Pressure increase

