

AC axial fan

sickle-shaped blades (S series), single-intake
with guard grille for short nozzle

S4D300-AS34-56 ebmpapst Datasheet

sales@fansco.com

www.fansco.com

Limited partnership · Headquarters Muldingen

Amtsgericht (court of registration) Stuttgart · HRA 590344

General partner Elektrobau Muldingen GmbH · Headquarters Muldingen

Amtsgericht (court of registration) Stuttgart · HRB 590142

Nominal data

Type	S4D300-AS34-56				
Motor	M4D068-CF				
Phase		3~	3~	3~	3~
Nominal voltage	VAC	230	230	400	400
Wiring		Δ	Δ	Y	Y
Frequency	Hz	50	60	50	60
Method of obtaining data		ml	ml	ml	ml
Valid for approval/standard		CE	CE	CE	CE
Speed (rpm)	min ⁻¹	1300	1400	1300	1400
Power consumption	W	68	90	68	90
Current draw	A	0.25	0.26	0.14	0.15
Max. back pressure	Pa	60	70	60	70
Max. back pressure	in. wg	0.24	0.28	0.24	0.28
Min. ambient temperature	°C	-25	-25	-25	-25
Max. ambient temperature	°C	60	55	60	55

ml = Max. load · me = Max. efficiency · fa = Free air · cs = Customer specification · ce = Customer equipment

Subject to change



AC axial fan

sickle-shaped blades (S series), single-intake
with guard grille for short nozzle

Technical description

Weight	2.5 kg
Size	300 mm
Motor size	68
Rotor surface	Painted black
Blade material	Press-fitted sheet steel blank, sprayed with PP plastic
Guard grille material	Steel, coated with black plastic (RAL 9005)
Number of blades	5
Airflow direction	V
Direction of rotation	Counterclockwise, viewed toward rotor
Degree of protection	IP44; installation- and position-dependent as per EN 60034-5
Insulation class	"B"
Moisture (F) / Environmental (H) protection class	H1
Max. permitted ambient temp. for motor (transport/storage)	+ 80 °C
Min. permitted ambient temp. for motor (transport/storage)	- 40 °C
Installation position	Shaft horizontal or rotor on bottom; rotor on top on request
Condensation drainage holes	On rotor side
Mode	S1
Motor bearing	Ball bearing
Touch current according to IEC 60990 (measuring circuit Fig. 4, TN system)	< 0.75 mA
Motor protection	Thermal overload protector (TOP) with basic insulation
With cable	Lateral
Protection class	I (with customer connection of protective earth)
Conformity with standards	EN 60335-1; CE



S4D300-AS34-56

AC axial fan

sickle-shaped blades (S series), single-intake
with guard grille for short nozzle

Product drawing

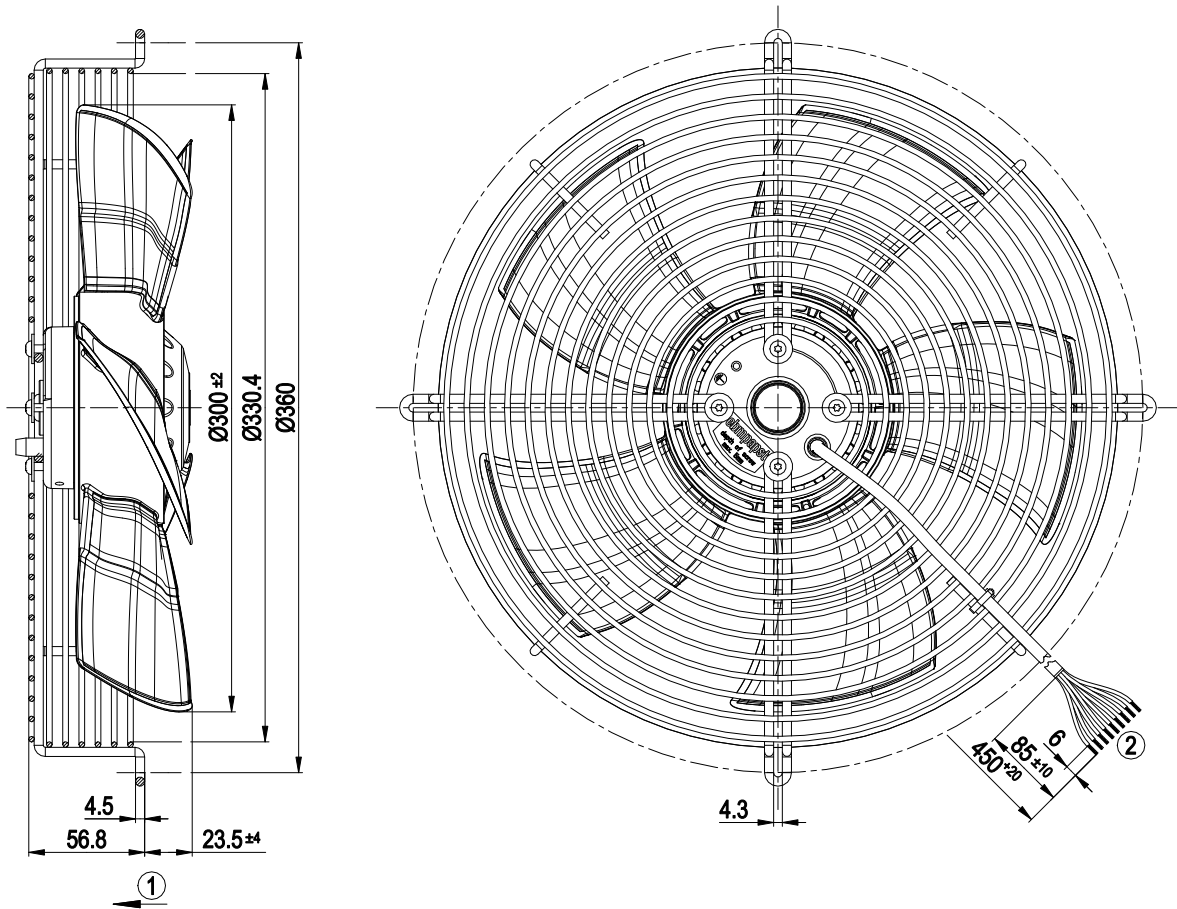

- | | |
|---|---------------------------------|
| 1 | Airflow direction "V" |
| 2 | Cable AWG20, 9x crimped splices |



AC axial fan

sickle-shaped blades (S series), single-intake
with guard grille for short nozzle

Connection diagram

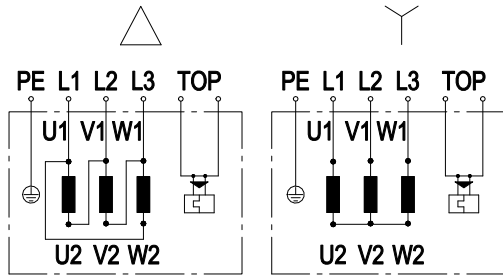

Note: Change of rotation direction by reversing two phases

Δ	Delta connection	Y	Star connection	L1	black
L2	blue	L3	brown	U1	black
V1	blue	W1	brown	U2	green
V2	white	W2	yellow	TOP	2x gray
PE	green/yellow				



AC axial fan

sickle-shaped blades (S series), single-intake
with guard grille for short nozzle

Curves: Air performance 50 Hz

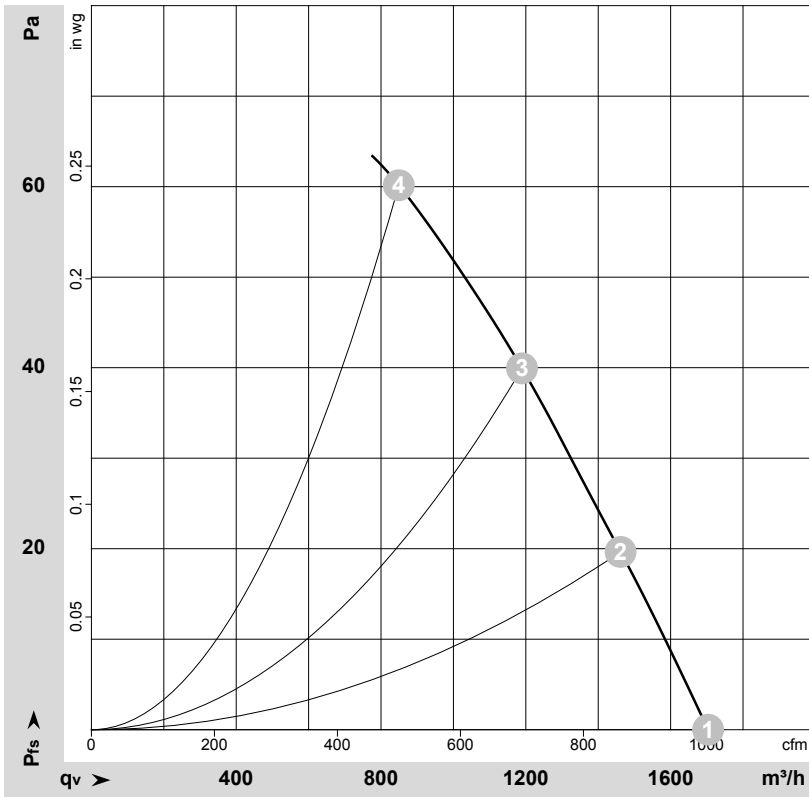

$\rho = 1.15 \text{ kg/m}^3 \pm 2 \%$

Measurement: LU-114649-1

Air performance measured according to ISO 5801 installation category A. For detailed information on the measurement setup, contact ebmpapst. Intake sound level: Sound power level according to ISO 13347 / sound pressure level measured at 1 m distance from fan axis. The values given are valid under the specified measuring conditions and may vary due to conditions of installation. For deviations from the standard configuration, the parameters have to be checked on the installed unit.

Measured values

	Wired	U	f	n	P_e	I	LpA_{in}	LwA_{in}	q_v	P_{fs}	q_v	P_{fs}
		V	Hz	min^{-1}	W	A	dB(A)	dB(A)	m^3/h	Pa	cfm	in. wg
1	Y	400	50	1370	53	0.13	52	59	1705	0	1000	0.00
2	Y	400	50	1350	57	0.13	51	58	1460	20	860	0.08
3	Y	400	50	1335	61	0.13	51	58	1190	40	700	0.16
4	Y	400	50	1300	68	0.14	57	65	850	60	500	0.24

Wired = Wiring · U = Voltage · f = Frequency · n = Speed (rpm) · P_e = Power consumption · I = Current draw · LpA_{in} = Sound pressure level intake side · LwA_{in} = Sound power level intake side
 q_v = Air flow · P_{fs} = Pressure increase



AC axial fan

sickle-shaped blades (S series), single-intake
with guard grille for short nozzle

Curves: Air performance 60 Hz

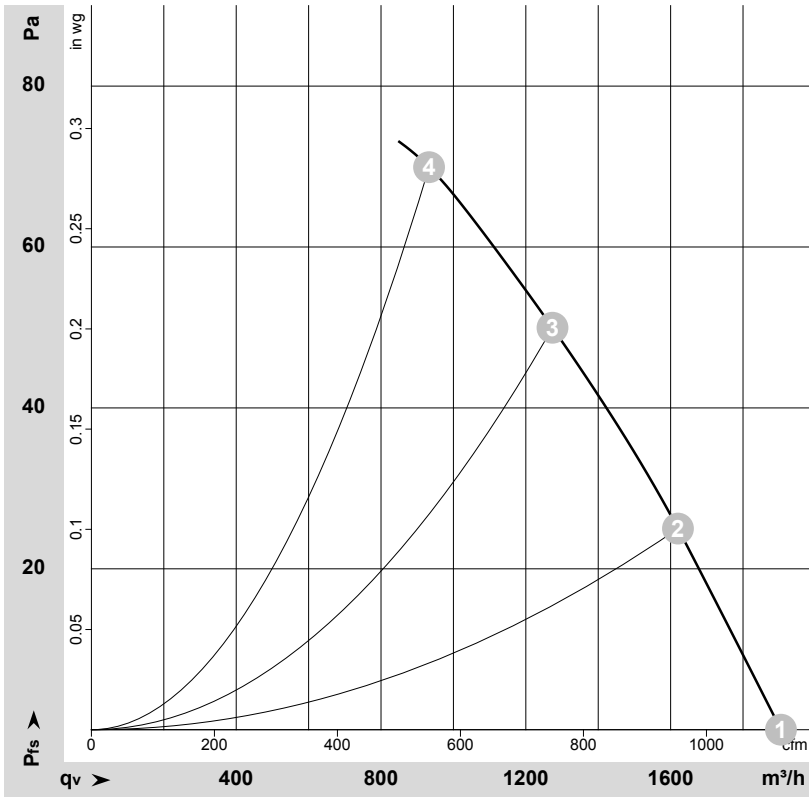

$\rho = 1.15 \text{ kg/m}^3 \pm 2 \%$

Measurement: LU-114653-1

Air performance measured according to ISO 5801 installation category A. For detailed information on the measurement setup, contact ebmpapst. Intake sound level: Sound power level according to ISO 13347 / sound pressure level measured at 1 m distance from fan axis. The values given are valid under the specified measuring conditions and may vary due to conditions of installation. For deviations from the standard configuration, the parameters have to be checked on the installed unit.

Measured values

	Wired	U	f	n	P_e	I	LpA_{in}	LwA_{in}	q_v	P_{fs}	q_v	P_{fs}
		V	Hz	min^{-1}	W	A	dB(A)	dB(A)	m^3/h	Pa	cfm	in. wg
1	Y	400	60	1530	69	0.13	55	62	1905	0	1120	0.00
2	Y	400	60	1495	75	0.13	54	61	1620	25	955	0.10
3	Y	400	60	1460	80	0.14	54	61	1275	50	750	0.20
4	Y	400	60	1400	90	0.15	60	68	935	70	550	0.28

Wired = Wiring · U = Voltage · f = Frequency · n = Speed (rpm) · P_e = Power consumption · I = Current draw · LpA_{in} = Sound pressure level intake side · LwA_{in} = Sound power level intake side
 q_v = Air flow · P_{fs} = Pressure increase

