

sickle-shaped blades (S series)

with guard grille for full nozzle

S3G910-KU25-03 ebmpapst Datasheet

sales@fansco.com

www.fansco.com

Limited partnership · Headquarters Mulfingen

Amtsgericht (court of registration) Stuttgart · HRA 590344

General partner Elektrobau Mulfingen GmbH · Headquarters Mulfingen

Amtsgericht (court of registration) Stuttgart · HRB 590142

## Nominal data

Type	S3G910-KU25-03	
Motor	M3G150-IF	
Phase		3~
Nominal voltage	VAC	400
Nominal voltage range	VAC	380 .. 480
Frequency	Hz	50/60
Method of obtaining data		ml
Speed (rpm)	min <sup>-1</sup>	980
Power consumption	W	2550
Current draw	A	3.9
Max. back pressure	Pa	220
Max. back pressure	in. wg	0.88
Min. ambient temperature	°C	-40
Max. ambient temperature	°C	60

ml = Max. load · me = Max. efficiency · fa = Free air · cs = Customer specification · ce = Customer equipment  
Subject to change

Occasional start-up at temperatures between -40 °C and -25 °C is permitted. For continuous operation at ambient temperatures below -25 °C (such as refrigeration applications), a fan design with special low-temperature bearings must be used.

## Data according to Commission Regulation (EU) 327/2011 (prEN 17166)

		Actual	Req. 2015			
01 Overall efficiency $\eta_{es}$	%	53.2	36.1	09 Power consumption $P_{ed}$	kW	2.38
02 Measurement category		A		09 Air flow $q_v$	m <sup>3</sup> /h	23685
03 Efficiency category		Static		09 Pressure increase $p_{fs}$	Pa	182
04 Efficiency grade N		57.1	40	10 Speed (rpm) n	min <sup>-1</sup>	980
05 Variable speed drive		Yes		11 Specific ratio*		1.00

Data obtained at optimum efficiency level.

\* Specific ratio =  $1 + p_{fs} / 100\,000\text{ Pa}$ 

LU-184391

The efficiency values displayed for achieving conformity with the Ecodesign Regulation EU 327/2011 has been reached with defined air duct components (e.g. inlet rings). The dimensions must be requested from ebm-papst. If other air conduction geometries are used on the installation side, the ebm-papst evaluation loses its validity/the conformity must be confirmed again. The product does not fall within the scope of Regulation (EU) 2019/1781 due to the exception specified in Article 2 (2a) (motors completely integrated into a product).



## Technical description

<b>Weight</b>	33 kg
<b>Size</b>	910 mm
<b>Motor size</b>	150
<b>Rotor surface</b>	Painted black
<b>Electronics housing material</b>	Die-cast aluminum, painted gray
<b>Blade material</b>	PP plastic
<b>Guard grille material</b>	Steel, coated with black plastic (RAL 9005)
<b>Number of blades</b>	5
<b>Blade pitch</b>	0°
<b>Airflow direction</b>	V
<b>Direction of rotation</b>	Clockwise, viewed toward rotor
<b>Degree of protection</b>	IP55
<b>Insulation class</b>	"F"
<b>Moisture (F) / Environmental (H) protection class</b>	H2
<b>Ambient temperature note</b>	Occasional start-up at temperatures between -40°C and -25°C is permitted. For continuous operation at ambient temperatures below -25°C (such as refrigeration applications), use must be made of a fan design with special low-temperature bearings.
<b>Max. permitted ambient temp. for motor (transport/storage)</b>	+80 °C
<b>Min. permitted ambient temp. for motor (transport/storage)</b>	-40 °C
<b>Installation position</b>	Shaft horizontal or rotor on bottom; rotor on top on request
<b>Condensation drainage holes</b>	On rotor side
<b>Mode</b>	S1
<b>Motor bearing</b>	Ball bearing
<b>Technical features</b>	<ul style="list-style-type: none"> <li>- Operation and alarm display with LED</li> <li>- External 15-50 VDC input (parameterization)</li> <li>- Alarm relay</li> <li>- Integrated PI controller</li> <li>- Configurable inputs/outputs (I/O)</li> <li>- MODBUS V6.3</li> <li>- Motor current limitation</li> <li>- RS-485 MODBUS-RTU</li> <li>- Soft start</li> <li>- Voltage output 3.3-24 VDC, Pmax = 800 mW</li> <li>- Control interface with SELV potential safely disconnected from the mains</li> <li>- Thermal overload protection for electronics/motor</li> <li>- Line undervoltage / phase failure detection</li> </ul>
<b>EMC immunity to interference</b>	According to EN 61000-6-2 (industrial environment)
<b>EMC interference emission</b>	According to EN 61000-6-3 (household environment), except EN 61000-3-2 for professionally used equipment with a total rated power greater than 1 kW
<b>Touch current according to IEC 60990 (measuring circuit Fig. 4, TN system)</b>	<= 3.5 mA
<b>Electrical hookup</b>	Terminal box
<b>Motor protection</b>	Reverse polarity and locked-rotor protection
<b>Protection class</b>	I (with customer connection of protective earth)
<b>Conformity with standards</b>	EN 61800-5-1; CE; UKCA

S3G910-KU25-03

# EC axial fan - AxiBlade

sickle-shaped blades (S series)

with guard grille for full nozzle

Approval

CSA C22.2 No. 77 + CAN/CSA-E60730-1; EAC; UL 1004-7 + 60730-1



# EC axial fan - AxiBlade

sickle-shaped blades (S series)

with guard grille for full nozzle

## Product drawing

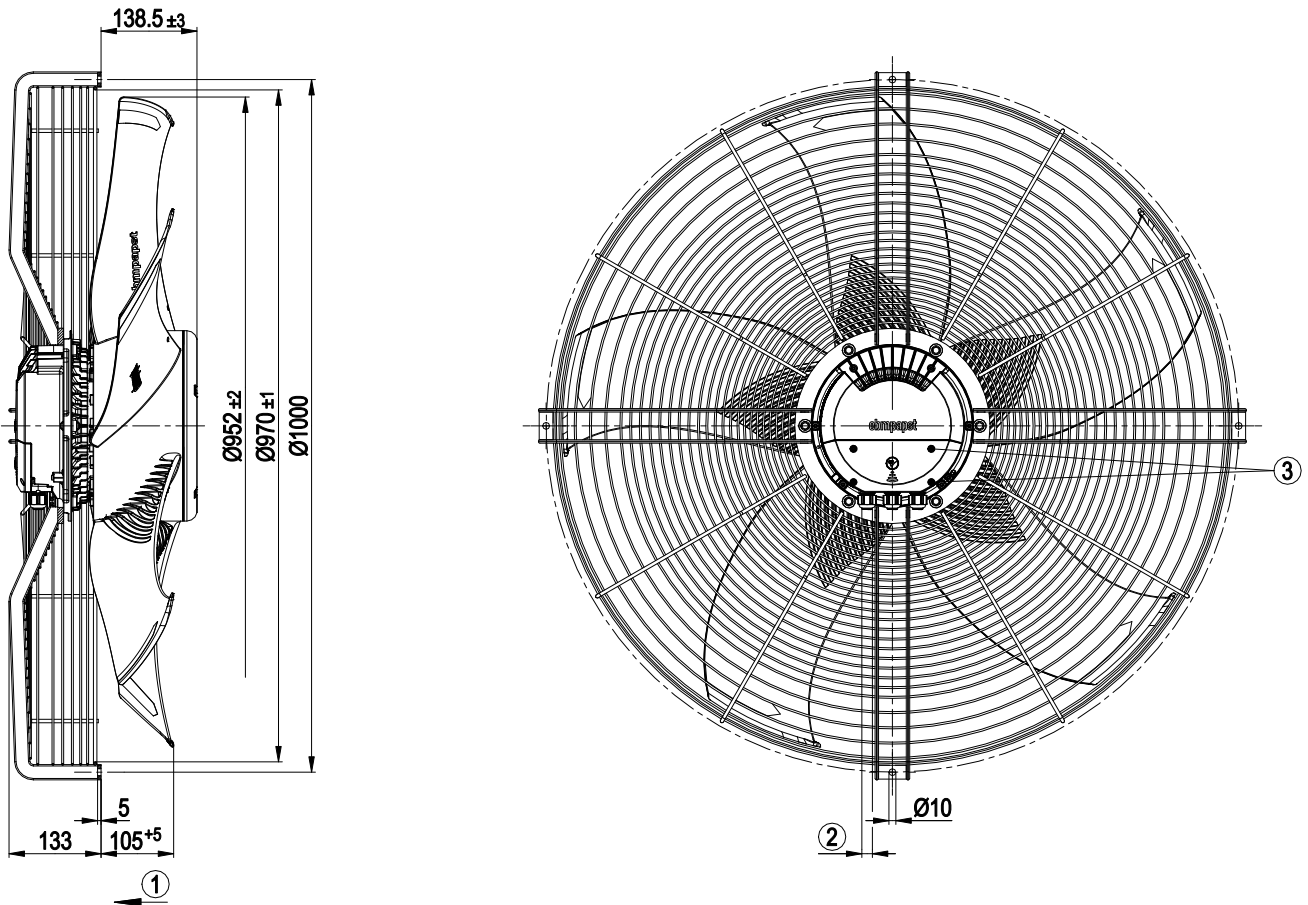

1	Airflow direction "V"
2	Cable diameter min. 4 mm, max. 10 mm, tightening torque $4 \pm 0.6$ Nm (The tightening torque is designed for PVC cables. If the cable materials are different, the tightening torque may have to be adjusted)
3	Tightening torque $1.5 \pm 0.2$ Nm



# EC axial fan - AxiBlade

sickle-shaped blades (S series)  
with guard grille for full nozzle

## Connection diagram

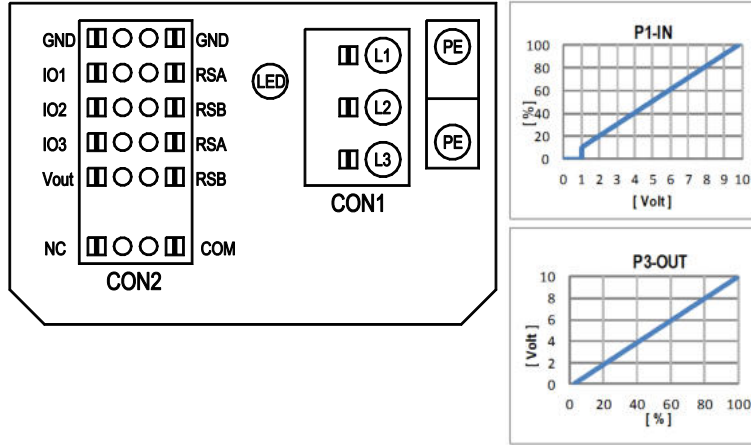

No.	Conn.	Designation	Function/assignment
	CON1	L1, L2, L3	Power supply, phase, see nameplate for voltage range
	PE	PE	Protective earth
	CON2	RSA	RS485 interface for MODBUS, RSA; SELV
	CON2	RSB	RS485 interface for MODBUS, RSB; SELV
	CON2	GND	Reference ground for control interface, SELV
	CON2	IO1	Function parameterizable (see "Optional interface functions" table) Factory setting: Digital input - high active, function: Disable input, SELV - inactive: Pin open or applied voltage < 1.5 VDC - active: applied voltage 3.5-50 VDC Reset function: Triggering of error reset on change of state from "enabled" to "disabled"
	CON2	IO2	Function parameterizable (see "Optional interface functions" table) Factory setting: Analog input 0-10 V / PWM, Ri=100 kΩ, function: Set value Characteristic curve parameterizable (see input characteristic curve P1-IN), SELV
	CON2	IO3	Function parameterizable (see "Optional interface functions" table) Factory setting: Analog output 0-10 V, max. 5 mA, function: Fan modulation level Characteristic curve parameterizable (see output characteristic curve P3-OUT), SELV
	CON2	Vout	Voltage output 3.3-24 VDC ±5%, Pmax=800 mW, voltage parameterizable Factory setting: 10 VDC short-circuit-proof, supply for external devices, SELV alternatively: 15-50 VDC input for parameterization via MODBUS without line voltage
	CON2	COM	Status relay, floating status contact, common connection, contact rating 250 VAC / 2 A (AC1) / min. 10 mA, reinforced insulation on supply side and on control interface side
	CON2	NC	Status relay, floating status contact, break for failure
		LED	green: status = good, ready for operation orange: status = warning red: status = failure
		P1-IN	Input characteristic curve
		P3-OUT	Output characteristic curve



# EC axial fan - AxiBlade

sickle-shaped blades (S series)

with guard grille for full nozzle

## Terminal/plug assignment

CON2	configurable IO mode	electrical specification	configurable IO functions: normal / inverse	MODBUS Register for IO mode configuration	
				MODBUS Register for IO mode configuration	MODBUS Register for IO mode configuration
IO1	○ Din1 (active high), digital input	active: applied voltage 3.5-50VDC, SELV not active: pin open or applied voltage < 1.5VDC		D158 [0]	
	○ Ain1 0-10V/PWM: analog input	RI = 100k, characteristic curve parameterizable, f <sub>PWM</sub> = 1k..10kHz, SELV		D158 [2]	
	○ Tach out (open collector output)	U <sub>max</sub> = 50VDC, I <sub>max</sub> = 20mA, SELV		D158 [5]	
	○ Diagnostics out (open collector output)	U <sub>max</sub> = 50VDC, I <sub>max</sub> = 20mA, SELV		D158 [6]	
IO2	○ Din2 (active high), digital input	active: applied voltage 3.5-50VDC, SELV not active: pin open or applied voltage < 1.5VDC		D159 [0]	
	○ Ain2 0-10V/PWM: analog input	RI = 100k, characteristic curve parameterizable, f <sub>PWM</sub> = 1k..10kHz, SELV		D159 [2]	
	○ Ain2 4-20mA: analog input	RI = 125R, characteristic curve parameterizable, SELV		D159 [3]	
	○ Din3 (active high), digital input	active: applied voltage 3.5-50VDC, SELV not active: pin open or applied voltage < 1.5VDC		D15A [0]	
IO3	○ Din3 (active low), digital input	active: applied voltage < 1.5VDC, SELV not active: pin open or applied voltage 3.5-50VDC		D15A [1]	
	○ PWMIn3: digital input, idle level high	PWM = 40Hz - 10kHz, characteristics parameterizable active: pin open or applied voltage 3.5-50VDC not active: applied voltage < 1.5VDC, SELV		D15A [7]	
	○ PWMIn3: digital input, idle level low	active: applied voltage 3.5-50VDC not active: pin open or applied voltage < 1.5VDC, SELV		D15A [8]	
	○ Aout3 0-10V: analog output	function parameterizable, max. 5mA max output frequency 300Hz SELV		D15A [4]	
RSA	○ Tacho out (pulses), analog output	0-10V/max. 5mA max output frequency 300Hz SELV		D15A [5]	
	○ Diagnostics out (pulses)	0-10V/max. 5mA max output frequency 300Hz, SELV		D15A [6]	
	○ Diagnostics out (pulses)	MODBUS RTU, specification V6.3, SELV			
RSB	RS485 bus connection,				
Vout	voltage output	voltage parameterizable 3.3..24VDC +/- 5%, P <sub>max</sub> =600mW, short-circuit-proof, supply for external devices, SELV		D16E [..]	
	alternatively: Input auxiliary power supply for parameterization via RS485/MODBUS RTU without line voltage	15..50VDC			

○ configurable option

For further information and additional functions see EC Control Software, Fan-Set-App, or MODBUS Parameter Specification V6.3



# EC axial fan - AxiBlade

sickle-shaped blades (S series)

with guard grille for full nozzle

## Curves: Air performance 50 Hz

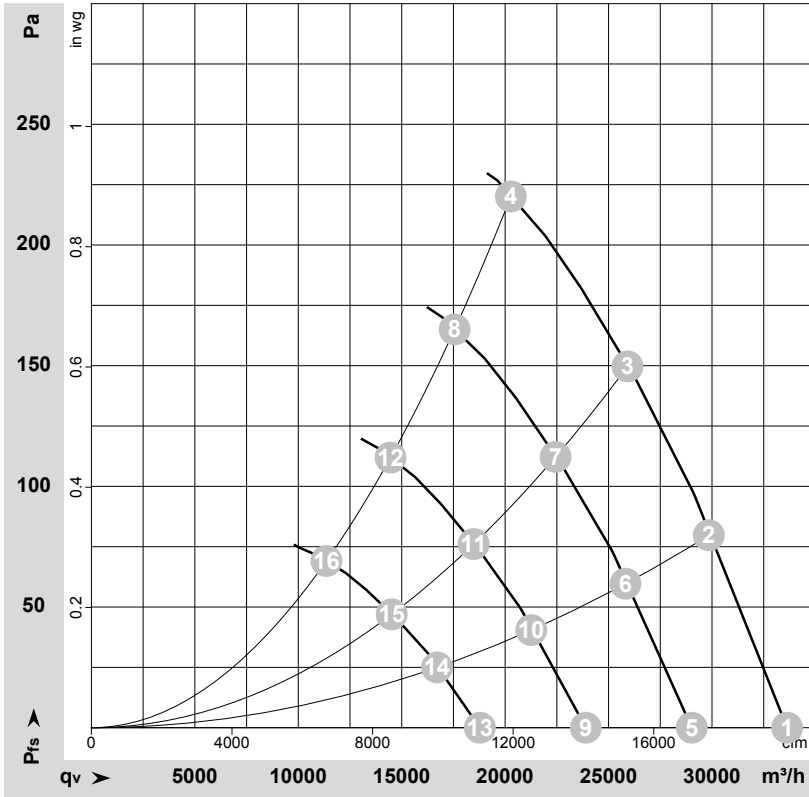

$\rho = 1.15 \text{ kg/m}^3 \pm 2 \%$

Measurement: LU-184391-1

Air performance measured according to ISO 5801 installation category A. For detailed information on the measurement setup, contact ebmpapst. Intake sound level: Sound power level according to ISO 13347 / sound pressure level measured at 1 m distance from fan axis. The values given are valid under the specified measuring conditions and may vary due to conditions of installation. For deviations from the standard configuration, the parameters have to be checked on the installed unit.

## Measured values

	U	f	n	P <sub>ed</sub>	I	LpA <sub>in</sub>	LwA <sub>in</sub>	LwA <sub>out</sub>	q <sub>v</sub>	P <sub>fs</sub>	q <sub>v</sub>	P <sub>fs</sub>
	V	Hz	min <sup>-1</sup>	W	A	dB(A)	dB(A)	dB(A)	m <sup>3</sup> /h	Pa	cfm	in. wg
1	400	50	980	1563	2.50	72	79	80	33630	0	19795	0.00
2	400	50	980	1938	3.04	69	76	77	29845	80	17565	0.32
3	400	50	980	2245	3.49	70	77	77	25915	150	15255	0.60
4	400	50	980	2550	3.90	75	82	82	20280	220	11935	0.88
5	400	50	850	1004	1.60	68	75	76	29025	0	17080	0.00
6	400	50	850	1255	1.97	66	73	74	25820	61	15195	0.24
7	400	50	850	1457	2.27	67	73	74	22440	112	13205	0.45
8	400	50	850	1663	2.57	72	78	79	17560	165	10335	0.66
9	400	50	700	561	0.90	63	70	71	23900	0	14070	0.00
10	400	50	700	701	1.10	61	68	69	21260	41	12515	0.16
11	400	50	700	814	1.27	62	68	69	18480	76	10875	0.31
12	400	50	700	929	1.44	67	74	74	14460	112	8510	0.45
13	400	50	550	272	0.43	57	64	65	18780	0	11055	0.00
14	400	50	550	340	0.53	55	62	63	16705	26	9835	0.10
15	400	50	550	395	0.61	56	62	63	14520	47	8545	0.19
16	400	50	550	451	0.70	61	67	68	11360	69	6685	0.28

U = Voltage · f = Frequency · n = Speed (rpm) · P<sub>ed</sub> = Power consumption · I = Current draw · LpA<sub>in</sub> = Sound pressure level intake side · LwA<sub>in</sub> = Sound power level intake side  
 LwA<sub>out</sub> = Sound power level outlet side · q<sub>v</sub> = Air flow · P<sub>fs</sub> = Pressure increase

