

S3G910-KJ86-37 ebmpapst Datasheet

sales@fansco.com

www.fansco.com

Limited partnership · Headquarters Muldingen

Amtsgericht (court of registration) Stuttgart · HRA 590344

General partner Elektrobau Muldingen GmbH · Headquarters Muldingen

Amtsgericht (court of registration) Stuttgart · HRB 590142

Nominal data

Type	S3G910-KJ86-37	
Motor	M3G112-EA	
Phase		1~
Nominal voltage	VAC	230
Nominal voltage range	VAC	200 .. 277
Frequency	Hz	50/60
Method of obtaining data		ml
Speed (rpm)	min ⁻¹	500
Power consumption	W	400
Current draw	A	1.7
Max. back pressure	Pa	57
Max. back pressure	in. wg	0.23
Min. ambient temperature	°C	-25
Max. ambient temperature	°C	60

ml = Max. load · me = Max. efficiency · fa = Free air · cs = Customer specification · ce = Customer equipment
Subject to change

Data according to Commission Regulation (EU) 327/2011 (EN 17166)

		Actual	Req. 2015			
01 Overall efficiency η_{es}	%	46.3	30.7	09 Power consumption P_{ed}	kW	0.34
02 Measurement category		A		09 Air flow q_v	m ³ /h	12050
03 Efficiency category		Static		09 Pressure increase p_{fs}	Pa	43
04 Efficiency grade N		55.6	40	10 Speed (rpm) n	min ⁻¹	500
05 Variable speed drive		Yes		11 Specific ratio*		1.00

Data obtained at optimum efficiency level.

The ErP data is determined using a motor-impeller combination in a standardized measurement setup.

* Specific ratio = $1 + p_s / 100\,000\text{ Pa}$

LU-191195



Technical description

Weight	17 kg
Size	910 mm
Motor size	112
Rotor surface	Painted black
Terminal box material	PP plastic
Electronics housing material	Die-cast aluminum, painted black
Blade material	Press-fitted sheet steel blank, sprayed with PP plastic
Guard grille material	Steel, coated with black plastic (RAL 9005)
Blade pitch	0°
Airflow direction	V
Direction of rotation	Clockwise, viewed toward rotor
Degree of protection	IP55
Insulation class	"F"
Moisture (F) / Environmental (H) protection class	H2
Ambient temperature note	Occasional start-up at temperatures between -40°C and -25°C is permitted. For continuous operation at ambient temperatures below -25°C (such as refrigeration applications), use must be made of a fan design with special low-temperature bearings.
Max. permitted ambient temp. for motor (transport/storage)	+80 °C
Min. permitted ambient temp. for motor (transport/storage)	-40 °C
Installation position	Shaft horizontal or rotor on bottom; rotor on top on request
Condensation drainage holes	On rotor side
Mode	S1
Motor bearing	Ball bearing
Technical features	<ul style="list-style-type: none"> - Output 10 VDC, max. 10 mA - Operation and alarm display - Alarm relay - Integrated PID controller - Power limiter - Motor current limitation - PFC, active - RS-485 MODBUS-RTU - Soft start - Control input 0-10 VDC / PWM - Control interface with SELV potential safely disconnected from the mains - Thermal overload protection for electronics/motor - Line undervoltage / phase failure detection
EMC immunity to interference	According to EN 61000-6-2 (industrial environment)
EMC circuit feedback	According to EN 61000-3-2/3
EMC interference emission	According to EN 61000-6-3 (household environment)
Touch current according to IEC 60990 (measuring circuit Fig. 4, TN system)	<= 3.5 mA
Electrical hookup	Terminal box
Motor protection	Thermal overload protector (TOP) internally connected
Protection class	I (with customer connection of protective earth)
Conformity with standards	EN 61800-5-1; CE

S3G910-KJ86-37

EC axial fan - AxiBlade

sickle-shaped blades (S series)

with guard grille for full nozzle

Approval

CSA C22.2 No. 77 + CAN/CSA-E60730-1; EAC; UL 1004-7 + 60730-1



EC axial fan - AxiBlade

sickle-shaped blades (S series)

with guard grille for full nozzle

Product drawing

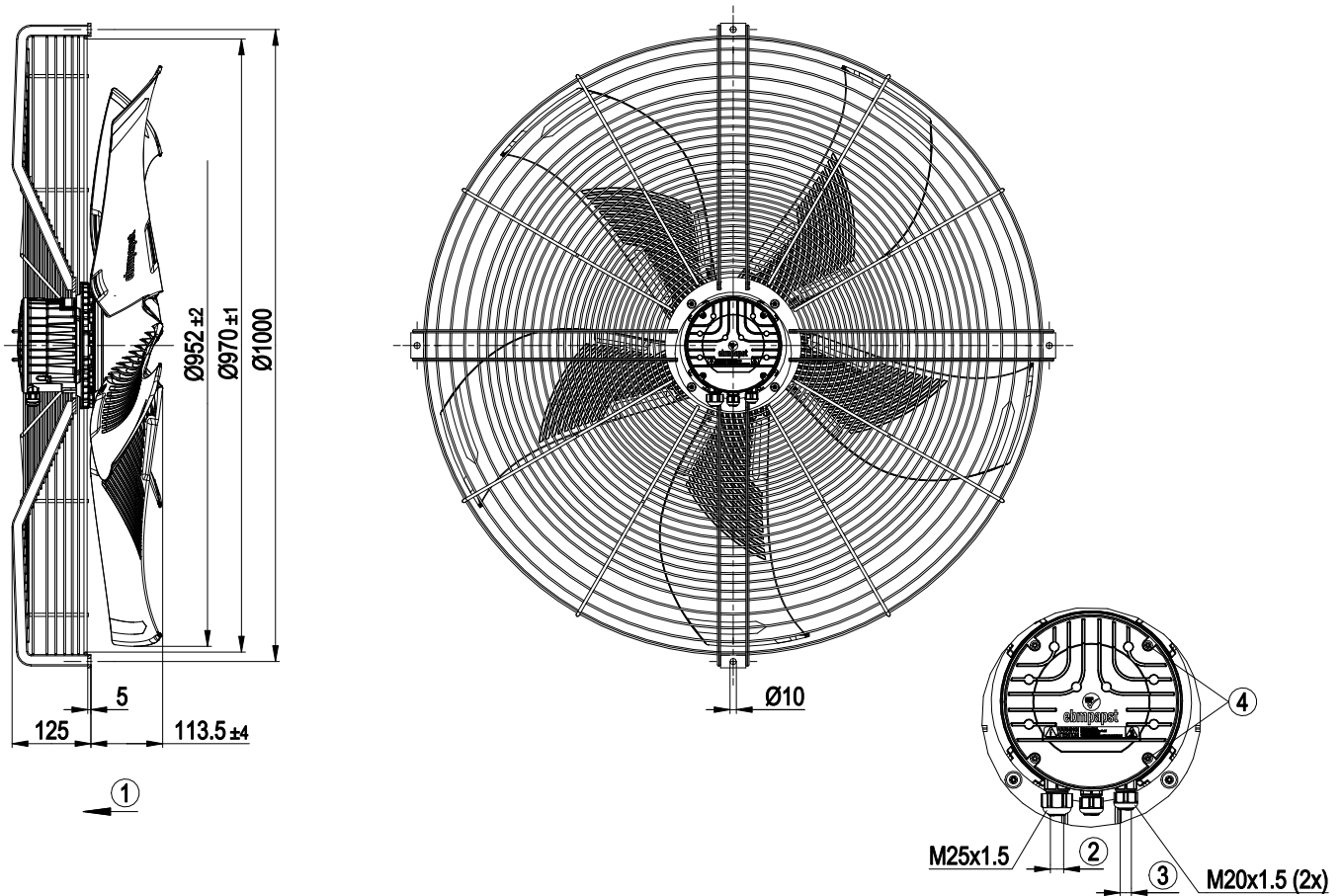

1	Airflow direction "V"
2	Cable diameter min. 8 mm, max. 12 mm, tightening torque 1.8±0.3 Nm (use must be made of seal provided) Cable diameter min. 4 mm, max. 10 mm, tightening torque 1.8±0.3 Nm
3	Cable diameter min. 6 mm, max. 10 mm, tightening torque 1.8±0.3 Nm (use must be made of seal provided) Cable diameter min. 4 mm, max. 7 mm, tightening torque 1.8±0.3 Nm
4	Tightening torque 3.5 ± 0.5 Nm

EC axial fan - AxiBlade

sickle-shaped blades (S series)

with guard grille for full nozzle

Connection diagram

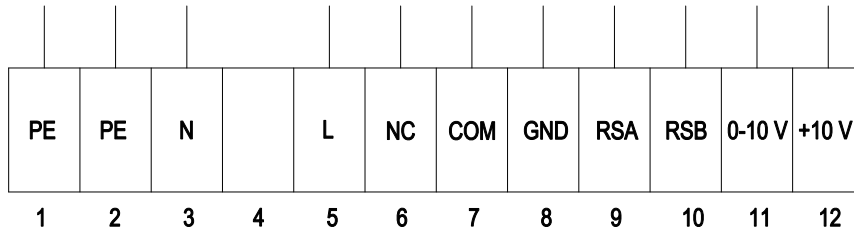

No.	Conn.	Designation	Function/assignment
1	PE	PE	Protective earth
2	PE	PE	Protective earth
3	N	N	Power supply, neutral conductor
4	-	-	not used
5	L	L	Power supply, phase
6	NC	NC	Status relay, floating status contact, break for failure, contact rating 250 VAC / 2 A (AC1) / min. 10 mA; basic insulation on supply side and reinforced insulation on control interface side
7	COM	COM	Status relay, floating status contact, common connection, contact rating 250 VAC / 2 A (AC1) / min. 10 mA; basic insulation on supply side and reinforced insulation on control interface side
8	GND	GND	Reference ground for control interface, SELV
9	RSA	RSA	RS485 interface for MODBUS, RSA; SELV
10	RSB	RSB	RS485 interface for MODBUS, RSB; SELV
11	0-10 V	0-10 V	Analog input (set value) SELV, 0-10 V, Ri = 100 kΩ, adjustable curve
12	+10 V	+10 V	Fixed voltage output 10 VDC, SELV, +10 V ±3%, max. 10 mA, short-circuit-proof, power supply for external devices (e.g. pot)



EC axial fan - AxiBlade

sickle-shaped blades (S series)

with guard grille for full nozzle

Curves: Air performance 50 Hz

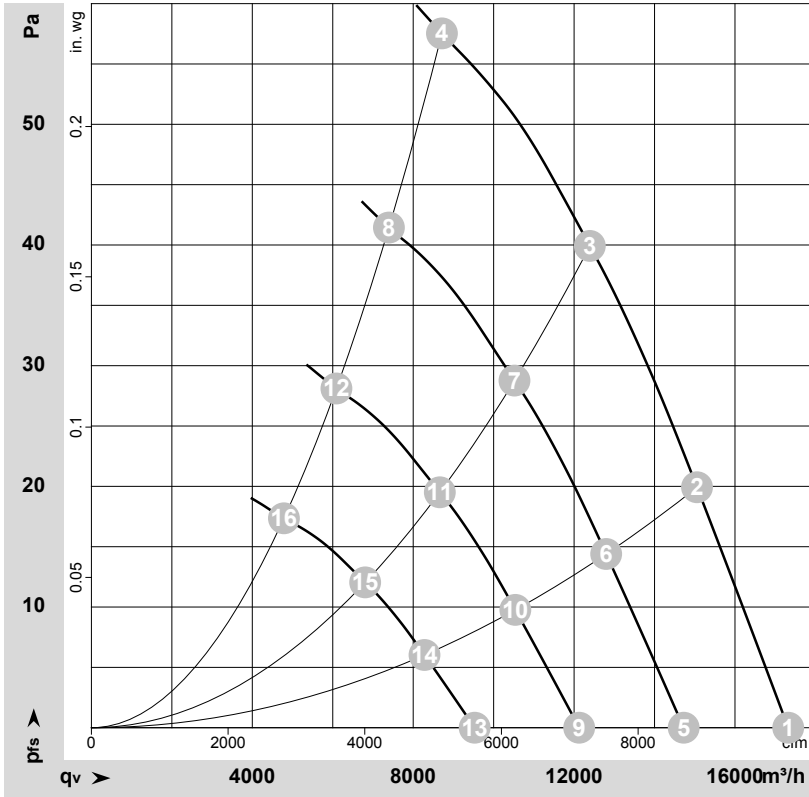

$\rho = 1.15 \text{ kg/m}^3 \pm 2 \%$

Measurement: LU-191195-1

Air performance measured according to ISO 5801 installation category A. For detailed information on the measurement setup, contact ebmpapst. Intake sound level: Sound power level according to ISO 13347 / sound pressure level measured at 1 m distance from fan axis. The values given are valid under the specified measuring conditions and may vary due to conditions of installation. For deviations from the standard configuration, the parameters have to be checked on the installed unit.

Measured values

	Wired	U	f	n	P _{ed}	I	LpA _{in}	LwA _{in}	LwA _{out}	q _v	p _{fs}	q _v	p _{fs}
		V	Hz	min ⁻¹	W	A	dB(A)	dB(A)	dB(A)	m ³ /h	Pa	cfm	in. wg
1	1~	230	50	500	231	1.03	57	62	62	17325	0	10195	0.00
2	1~	230	50	500	285	1.27	55	61	61	15055	20	8860	0.08
3	1~	230	50	500	335	1.48	54	61	61	12390	40	7295	0.16
4	1~	230	50	500	400	1.70	60	68	69	8715	57	5130	0.23
5	1~	230	50	425	142	0.64	53	58	58	14725	0	8665	0.00
6	1~	230	50	425	175	0.78	51	57	57	12800	15	7535	0.06
7	1~	230	50	425	205	0.90	50	57	57	10520	29	6190	0.12
8	1~	230	50	425	243	1.07	56	64	65	7395	41	4355	0.16
9	1~	230	50	350	79	0.35	48	53	53	12125	0	7140	0.00
10	1~	230	50	350	98	0.43	47	53	52	10540	10	6205	0.04
11	1~	230	50	350	114	0.50	45	52	52	8660	20	5100	0.08
12	1~	230	50	350	136	0.60	51	59	60	6090	28	3585	0.11
13	1~	230	50	275	38	0.17	42	47	47	9530	0	5610	0.00
14	1~	230	50	275	47	0.21	40	46	46	8280	6	4875	0.02
15	1~	230	50	275	55	0.24	39	46	46	6805	12	4005	0.05
16	1~	230	50	275	66	0.29	45	53	54	4785	17	2815	0.07

Wired = Wiring · U = Voltage · f = Frequency · n = Speed (rpm) · P_{ed} = Power consumption · I = Current draw · LpA_{in} = Sound pressure level intake side · LwA_{in} = Sound power level intake side · LwA_{out} = Sound power level outlet side · q_v = Air flow · p_{fs} = Pressure increase

